

ThorburnFlex

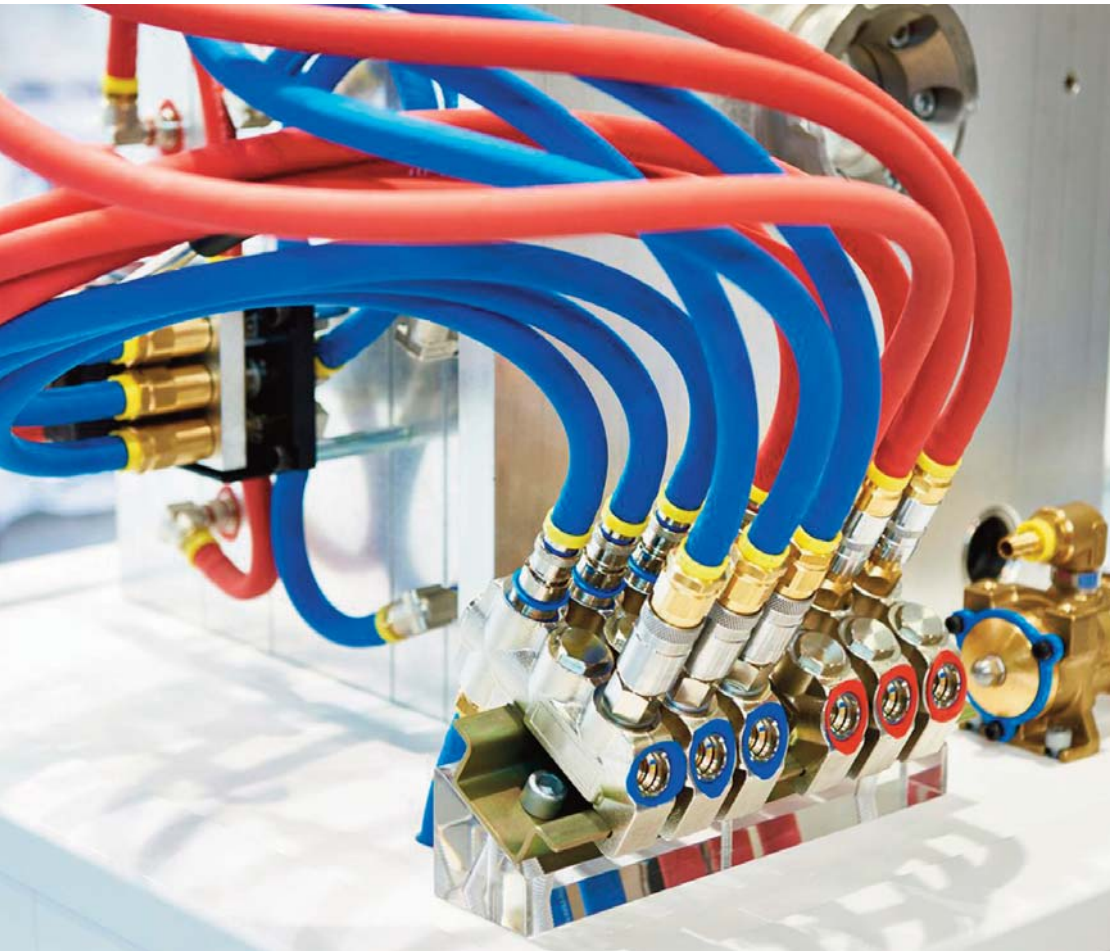

Clean Power Generation



Petrochemical Processing



Material Processing

AIR • WATER • STEAM
INDUSTRIAL HOSE ASSEMBLIES
Engineered Solutions For Pipe Motion



www.thorburnflex.com



ThorburnFlex

Thorburn Flex is an innovative manufacturer of specialized engineered flexible piping systems (i.e. custom hose assemblies and expansion joints). Since 1954, Thorburn’s corporate mission evolution and business philosophy have been customer driven and targeted to select niche applications where Thorburn can achieve clear positions of sustainable technological and market share leadership. Thorburn is committed to a policy of continuous development and research to provide engineered solutions for pipe motion that set the industry standards for quality, safety, environmental protection, durability and value.



European
Conformity



ISO
9001



B31.1,
B31.3



ASME “NPT”
Sec. III Class 1



ASME “U”
Sec. VIII Div. 1



N285.0, B51
CGA CR96-001



97/23/EC
Module H



UL
536

ISCIR Romania | CNCAN Romania | EN 13480-2002 | HAF 604 China | TSG China

www.thorburnflex.com

Table Of Contents

Design, Quality and Manufacturing			
Engineered Industrial Hose Assemblies	4	Thorburn Bolt Clamps	102
Hose Manufacturing	5	Thorburn Spiral Clamps	104
Typical Industries that use Air, Water & Steam Hose Assemblies	6	Thorburn Perma Clamps	105
Thorburn Air Hose Assemblies		Thorburn Hose & Bag Clamps	106
Series (N)10TA - Multi-Purpose Air Hose	8	Thorburn High Pressure Interlocking Clamps	107
Series (N)11TANC - Non-Conductive Air Hose	9	Thorburn Crimp Ferrules	108
Series (N)14TA - Standard Pressure Air Hose	10	Thorburn Special Purpose Air Hose	
Series (N)15TA - Extra High Pressure Air Hose	11	Series (N)PT/PTC Polyurethane Air Hose Assemblies	112
Series (N)16TA - Extra High Pressure Wire Braid Air Hose	11	Series (N)TS Nylon Air Hose Assemblies	100
Series (N)22TA "Cold-Flex" - Premium General Purpose Air Hose	12	Series (N)LOL - Push-On / Lock-In Air Hose	115
Series (N)110TA "Blow Flex" - EPDM Hot Air Blower Hose	13	Series (N)42TA - PVC Breathing Hose	118
Series (N)17TA - PVC Multi-Purpose Phthalate Free Hose	14	Series (N)43TA/44TA - EPDM Breathing Hose	119
Series (N)20TA - PVC/Polyurethane Phthalate Free Hose	15	Thorburn Special Purpose Water Hose	
Series (N)21TA - Ultra Flexible PVC Hose	15	Series (N)TPWBLU - Standard Pressure Washer Hose	120
Series (N)18TA - PVC Clear Phthalate Free Hose	16	Series (N)23TW - High Pressure Water Blast Hose	123
Thorburn Water Hose Assemblies		Series (N)23TWX - Ultra High Pressure Water Blast Hose	123
Series (N)21TW - High Pressure Water Discharge Hose	18	Series (N)11TWB - Ultra High Pressure Hydro-Demolition Hose	126
Series (N)24TW - Heavy Duty Water Suction Hose	19	Series (N)44TWB - Ultra High Pressure Hydro-Demolition Hose	127
Series (N)224TW - Corrugated Heavy Duty Water Suction Hose	19	Series (N)66TWB - Ultra High Pressure Hydro-Demolition Hose	127
Series (N)26TW/(N)26TWN - Premium Wash-Down Hose	20	Series (N)88TWB - Ultra High Pressure Hydro-Demolition Hose	128
Series (N)27TW/(N)27TWN - Paper Mill Wash-Down Hose	21	Series (N)22TWH - High Pressure TPU Layflat Hose	135
Series (N)118TW - PVC Clear Multi-Purpose Phthalate Free Hose	22	Series (N)22TWH - Very High Pressure TPU Layflat Hose	135
Series (N)220TW - PVC/Polyurethane Phthalate Free Hose	23	Series (N)22TW - Water Suction & Discharge Layflat PVC Hose	137
Series (N)221TW - Ultra Flexible PVC Phthalate Free Hose	23	Series (N)22TWB - Water Suction & Discharge Layflat PVC Hose	138
Series (N)25TWH - PVC Phthalate Free Water Suction Hose	24	Series (N)223TW - Rubber Covered Abrasion Resistant Fire Hose	139
Series (N)255TWH - PVC Phthalate Free Water Suction Hose	25	Series (N)224TW - Premium Single Jacket Fabric Fire Hose	140
Series (N)256TWH - PVC Phthalate Free Heavy Duty Water Suction Hose	25	Series (N)225TW - Double Jacket Fabric Fire Hose	140
Thorburn Steam Hose Assemblies		Thorburn Hose Shank Couplings For PVC Layflat and Fire Hose	141
Series (N)30TS - Rubber Steam Hose	27	Series FHS Fire Hose Couplings	143
Series (N)32TS/(N)33TS - Rubber Steam Hose	27	Series TIC Instantaneous Couplings	145
Thorburn Standard Hose Couplings		Series TERC Expansion Ring Couplings	149
Series HB - Brass Hose Barb Fittings	34	Thorburn Fire Hose Adapters	
Thorburn Qlaw™ Quick Acting Claw Coupling System - Type B Canada/US	40	Series TFSA Swivel Adapters - Pin Lug	151
Thorburn Thor-Quick Dual Lock Safety Hose Couplings	44	Series THA Hydrant Adapter - Pin Lug	152
Series BQC MacDonald Style Quick Action Couplings	46	Series TFMHN Female to Male Hex Nipples	153
Series TD Industrial Interchange Couplings	50	Series TMMHN Male to Male Hex Nipple	154
Series (N)T4304 Ring Lock Single Shut-Off Valve Couplings - 1/4" Body	54	Series TCGA Cam & Groove NST Adapters	155
Series (N)T4306 Ring Lock Single Shut-Off Valve Couplings - 3/8" Body	56	Series TMMA Male to Male Adapters - Pin Lug	156
Thorburn Air Hose 360° Swivels & Air Hose Manifolds	58	Series TFSMA Female Swivel to Male Adapters - Pin Lug	156
Thorburn Combination Hose Shank Couplings - Low Pressure	60	Series TCH Camlock Hydrant Adapters - Pin Lug	157
Thorburn Shank Couplings For Water Discharge and Suction Services	62	Series TBC Brass Caps - Pin Lug	157
Series 633 Camlock Couplings	66	Thorburn Fire Hose Nozzles	158
Series 733 - 4 Lever High Pressure Camlock Couplings	72	Accessories	
Series TB Bauer Type B Style Lever Couplings	74	Thorburn Brass Ball Valves	160
Series TP Perrot Type C Style Lever Couplings	78	Thorburn Spray Nozzles	161
Series 70 Hose Couplings for Bolt-On Safety Clamps	82	Thorburn Foot Valves for Water Suction Hose	162
Series 80 Hose Couplings for Bolt-On Safety Clamps	86	Thorburn Strainers and Attachments	162
Thorburn Heavy Duty Ground Joint Couplings	88	Thorburn Whip Checks & Whip Socks	165
How To Order Thorburn Industrial Hose Assemblies	92	Thorburn THOR-REEL - Hose Reels	169
Hose Clamps		Other Thorburn Hose Accessories	175
Series 70BSC - Bolt-On Safety Clamps	94	Technical Data	
Series 80BSC - Bolt-On Safety Clamps	95	Chemical Resistance Guides	176
Series TBRC Pipe Repair Clamps	96	Conversion and Calculation Charts	200
Thorburn Worm Gear Clamps	98	General Information	206
Thorburn Two Ear Clamps and Accessories	99	General Maintenance, Testing and Inspection of Hose	215
Thorburn Preformed Clamps and Accessories	100	Hose Assembly Maintenance and Storage	216
		Glossary of Terms	218

Engineered Industrial Hose Assemblies

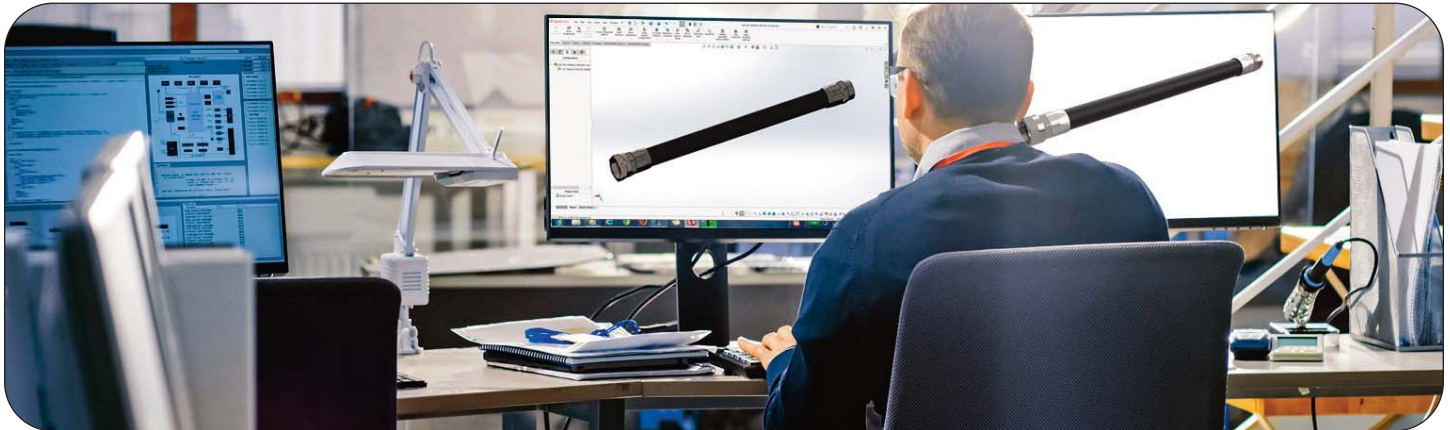

Thorburn's design team uses FEA & Solidworks to provide engineered pipe motion solutions

Engineering Capabilities & Experience

Thorburn's design engineering expertise is supported by advanced FEA software that offers powerful and complete solutions for both routine and sophisticated engineering problems. Thorburn's engineers can analyse and provide innovative solutions for pipe and duct motion problems including dynamic vibration, nonlinear static, linear static, thermal gradient through material wall thickness, acoustic impedance and fatigue using a common model data structure and integrated solver technology.

Design & Materials

- ASME Code Sections I, II, III, VIII, IX, B31.1 & B31.3
- ISO 10380 Corrugated Metal Hose & Hose Assemblies
- NACE MRO175-2009/ISO 15156-2009 compliance
- FEA - Finite Element Analysis

Welding and Fabrication Capabilities

- Arc, Pulse Arc, TIG, MIG, Core Wire
- Tube Welding, Track Welding, Automated Flame Cutting & Welding
- Rolls, Positioners, Turntables
- Automated Tube Welding 6mm (1/4") to 300mm (12")
- Lifting Capacity 22,000 lbs (10,000 kg)
- Crimping from 3 mm (1/8") to 600 mm (24")

NDT/NDE Programs & Design Verification Testing

- Weld X-Ray to 300KV-5MA / Welds Dye Penetrant to ASME Sec V
- Vacuum Testing 29.9" HG and Hydrostatic or Nitrogen Pressure Testing to 1,000 bar (15,000 psi)
- Impulse Testing to 680 bar (10,000 psi) at 204°C (400°F).
- Burst Testing up to 4,000 bar (60,000 psi)
- Pliability Fatigue & Deflection Testing ISO 10380:2012
- Seismic & Vibration Analysis in Acceptance with ASME Sec III
- Helium Mass Spectrometer Leak Testing

Fabrication Certification

- Welders and welding procedures: ASME Section VIII, IX, B31.1, B31.3, CSA B51 and Section III NPT (in progress)
- EN13480-2002: European Industrial Metallic Piping Standard & 97/23/EC (Pressure Equipment Directive)
- Canadian Gas Association (CGA) Certification: Standards CAN/CGA-8.1-M86, CGA96, UL96, UL536
- ISO 10380 Corrugated Metal Hose & Hose Assemblies
- Pressure Vessel Certification: CRN 0H0012. All Canadian Provinces & Territories
- Monel Chlorine Transfer: Chlorine Institute Spec. 135-3
- Hose Assemblies Degreased, Cleaned and Capped for Oxygen or Chlorine Service

Quality Assurance Certification & Compliance

- CSA N299.1, ISO 9001, ASME B31.1, B31.3 Section III, ASME Section VIII, Div 1 "U", CSA B51, NCA 4000 NQA-1, CSA N285.0, ASME NPT, AS 9100 (in progress), ISO IEC 17025



Burst testing up to 4000 BAR

Hose Manufacturing



DN 3 (1/8") to DN600 (24") Crimper
Largest in North America

Crimper - More than 3 million lbf (1.5 million kgf)

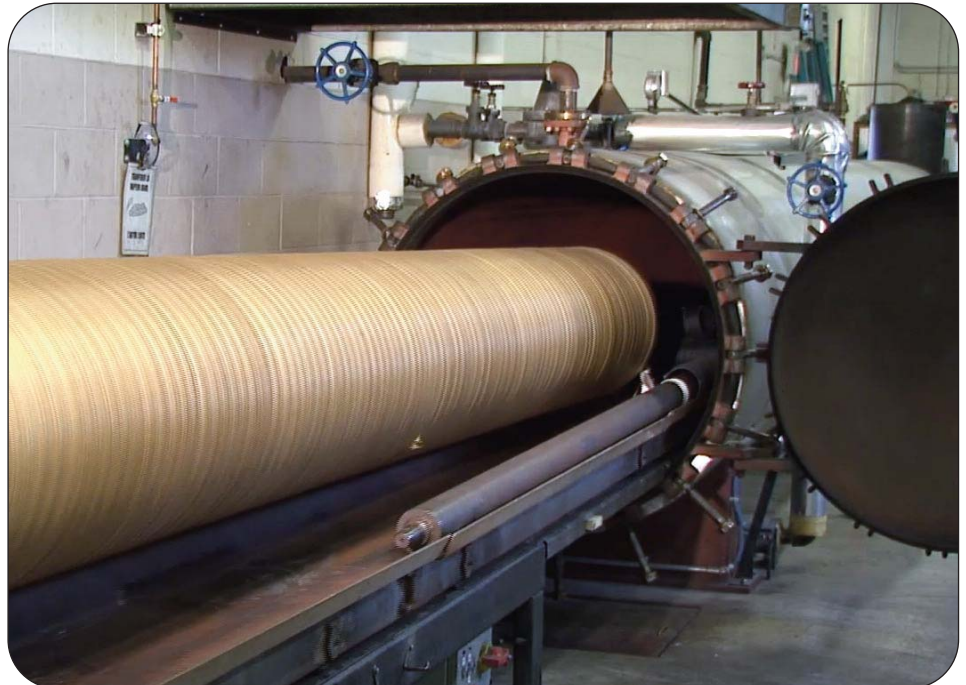

Rubber hose vulcanizing process



Hose tube layer winding process



Fabric reinforcement winding process

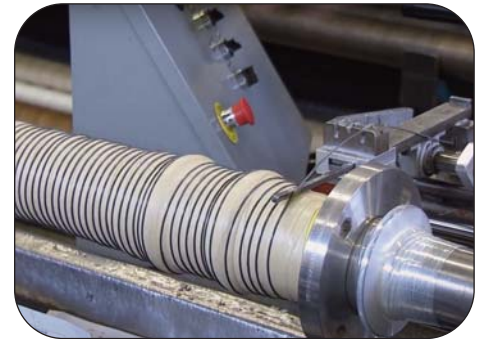

Automated helical wire winding process



Automated winding cover application process



High pressure clamped hose assembly



Hose assembly crimping process

Typical Industries that use Air, Water & Steam Hose Assemblies



Construction Sites



Mining



Quarries



Marine & Offshore



Aluminum Processing



Pulp & Paper Mills



Steel Mills



Loading / Unloading



Food Processing



Agriculture



Breweries



Sanitation



Thorburn Rubber Air Hose Assemblies



Thorburn Series (N)10TA

Multi-Purpose Air Hose

Thorburn Series (N)10TA: is a versatile EPDM rubber blended multi-purpose air hose. Thorburn's Series 10TA is flexible, lightweight and is one of our most popular air hose. It is an ideal air hose for industrial in-plant use, agriculture, construction and marine applications.

Applications: Air tools, nailers, staplers and jack hammers, heavy duty heater hose, low pressure agricultural spray hose.



Safety Factor: 3:1

Thorburn Part #	Hose I.D.		Hose O.D.		Design Pressure		Weight	
	mm	in	mm	in	bar	PSI	kg/m	lb/ft
(N)10TA04(X)	6	1/4	13	0.50	13.8	200	0.13	0.09
(N)10TA04A(X)	6	1/4	16	0.62	17.2	250	0.22	0.15
(N)10TA05(X)	8	5/16	16	0.62	13.8	200	0.19	0.13
(N)10TA05A(X)	8	5/16	18	0.69	17.2	250	0.25	0.17
(N)10TA06(X)	10	3/8	18	0.69	13.8	200	0.22	0.15
(N)10TA06A(X)	10	3/8	19	0.75	17.2	250	0.28	0.19
(N)10TA08(X)	12	1/2	21	0.84	13.8	200	0.31	0.21
(N)10TA08A(X)	12	1/2	21	0.84	17.2	250	0.31	0.21
(N)10TA10(X)	16	5/8	25	1.00	13.8	200	0.45	0.30
(N)10TA10A(X)	16	5/8	25	1.00	17.2	250	0.45	0.30
(N)10TA12(X)	20	3/4	31	1.20	17.2	250	0.60	0.40
(N)10TA16(X)	25	1	36	1.42	17.2	250	0.70	0.47
(N)10TA20(X)	30	1 1/4	45	1.75	13.8	200	1.04	0.70
(N)10TA24(X)	40	1 1/2	51	2.00	13.8	200	1.21	0.81
(N)10TA32(X)	50	2	66	2.60	10.3	200	1.47	0.99

N is used in the part number only when a Canadian CRN is required, when a code requirement must be met or material traceability is required. 4:1 safety factor required. (X) = Other Color Code, Ex: (N)10TA04YL

Construction

Tube: Smooth, weather resistant EPDM (Type H)

Reinforcement: Multiple plies of high tensile braided fabric

Cover: Light red, smooth, weather and ozone resistant EPDM (Type H). Also available in other colors on request add suffix **YL**=Yellow, **GR**=Green, **BL**=Blue if color coding is required. Minimum quantities may apply.

Operating Temperature:

-40°C to 100°C (-40°F to 212°F)

Typical Hose End Couplings:

(Comes with Clamp or Crimped Sleeve)

Hose Barb Fittings (PG 34)

Qlaw™ Quick Acting Claw Couplings (PG 40)

Thor-Quick Dual Lock Safety Couplings (PG 44)

BQC Series MacDonald Style Couplings (PG 46)

Industrial Interchange Couplings (PG 50)

Shank Hose Couplings (PG 60)

Camlock Quick Couplings (PG 64)

Heavy Duty Ground Joint Couplings (PG 88)

See full compatible couplings list (Pages 30-33)

Thorburn Premium Rubber Air Hose Assemblies



Thorburn Series (N)11TANC Premium Multi-Purpose Non-Conductive Air Hose



Thorburn Series (N)11TANC: is an extremely versatile multi-purpose, premium quality air hose. Made from oil resistant rubbers that can be used to convey gasoline, kerosene, fuel oil and lubricating oils.

Applications: Lubricated air tools found in quarries, construction sites, ship-building and railroads.

Safety Factor: 3:1

Thorburn Part #	Hose I.D.		Hose O.D.		Design Pressure		Weight	
	mm	in	mm	in	bar	PSI	kg/m	lb/ft
(N)11TANC04A	6	1/4	10.0	0.63	20.7	300	0.25	0.17
(N)11TANC05A	8	5/16	17.5	0.69	20.7	300	0.27	0.18
(N)11TANC06A	10	3/8	19.1	0.75	20.7	300	0.31	0.20
(N)11TANC08A	12	1/2	22.4	0.88	20.7	300	0.34	0.26
(N)11TANC10A	16	5/8	25.4	1.00	20.7	300	0.45	0.30
(N)11TANC12A	20	3/4	31.8	1.25	20.7	300	0.74	0.50
(N)11TANC16A	25	1	38.1	1.50	20.7	300	0.94	0.63
(N)11TANC20A	30	1 1/4	44.5	1.75	20.7	250	1.05	0.72
(N)11TANC24A	40	1 1/2	50.8	2.00	20.7	250	1.24	0.84

N is used in the part number only when a Canadian CRN is required, when a code requirement must be met or material traceability is required. 4:1 safety factor required.

Construction

Tube: Smooth fuel, oil & weather resistant Nitrile Blend (Type D)

Reinforcement: Multiple plies of high tensile spiraled fabric braid

Cover: Red, smooth, fuel, oil & weather resistant Nitrile (Type A)/PVC blend

Operating Temperature: -32°C to 85°C (-25°F to 185°F)

Typical Hose End Couplings:

(Comes with Clamp or Crimped Sleeve)

Hose Barb Fittings (PG 34)

Qlaw™ Quick Acting Claw Couplings (PG 40)

Thor-Quick Dual Lock Safety Couplings (PG 44)

BQC Series MacDonald Style Couplings (PG 46)

Industrial Interchange Couplings (PG 50)

Shank Hose Couplings (PG 60)

Camlock Quick Couplings (PG 64)

Heavy Duty Ground Joint Couplings (PG 88)

See full compatible couplings list (Pages 30-33)

Thorburn Rubber High Pressure Air Hose Assemblies



Thorburn Series (N)14TA

Standard Pressure Air Hose



Thorburn Series (N)14TA: is a 300 psi (20.7 Bar) durable, kink resistant, mandrill built hose that is designed to withstand the abusive use in road construction, mines, quarries, docks and shipyards.

Applications:

Jack hammers, air tools and other air operated equipment.

Safety Factor: 3:1

Thorburn Part #	Hose I.D.		Hose O.D.		Design Pressure		Weight	
	mm	in	mm	in	bar	PSI	kg/m	lb/ft
(N)14TA08	12	1/2	23	0.91	20.7	300	0.48	0.32
(N)14TA12	20	3/4	31	1.22	20.7	300	0.71	0.48
(N)14TA16	25	1	37	1.47	20.7	300	1.04	0.70
(N)14TA20	30	1 1/4	45	1.78	20.7	300	1.09	0.73
(N)14TA24	40	1 1/2	52	2.06	20.7	300	1.38	0.93
(N)14TA32	50	2	66	2.59	20.7	300	2.32	1.56
(N)14TA40	65	2 1/2	79	3.13	20.7	300	2.46	1.65
(N)14TA48	80	3	93	3.66	17.2	250	2.98	2.00
(N)14TA64	100	4	117	4.66	17.2	250	4.03	2.71

N is used in the part number only when a Canadian CRN is required, when a code requirement must be met or material traceability is required. 4:1 safety factor required.

Construction

- Tube:** Smooth synthetic rubber blend compounded to resist lubricating oil mist
 - Reinforcement:** Multiple plies of spiraled high tensile calendared fabric
 - Cover:** Thick yellow wrapped finish cut, abrasion, weather & ozone resistant
 - Operating Temperature:** -40°C to 80°C (-40°F to 180°F)
 - Typical Hose End Couplings:**
 - (Comes with Clamp or Crimped Sleeve)
 - Qlaw™ Quick Acting Claw Couplings (PG 40)
 - Thor-Quick Dual Lock Safety Couplings (PG 44)
 - BQC Series MacDonald Style Couplings (PG 46)
 - Shank Hose Couplings (PG 60)
 - Heavy Duty Ground Joint Couplings (PG 88)
- See full compatible couplings list (Pages 30-33)

Thorburn Series (N)15TA

Extra High Pressure Air Hose



Thorburn Series (N)15TA: is a 400 psi (27.7 Bar) durable, kink resistant, man-drill built hose that is designed to withstand the abusive use in road construction, mines, quarries, docks and shipyards.

Applications:

Jack hammers, air tools and other air operated equipment.

Safety Factor: 3:1

Thorburn Part #	Hose I.D.		Hose O.D.		Design Pressure		Weight	
	mm	in	mm	in	bar	PSI	kg/m	lb/ft
(N)15TA08	12	1/2	23.8	0.87	27.6	400	0.45	0.30
(N)15TA12	20	3/4	31.8	1.30	27.6	400	0.75	0.50
(N)15TA16	25	1	38.9	1.58	27.6	400	1.04	0.70
(N)15TA20	30	1 1/4	46.0	1.85	27.6	400	1.59	1.07
(N)15TA24	40	1 1/2	52.3	2.10	27.6	400	1.79	1.20
(N)15TA32	50	2	65.8	2.63	27.6	400	2.32	1.56
(N)15TA48	80	3	95.3	3.75	27.6	400	4.27	2.87
(N)15TA64	100	4	120.7	4.75	27.6	400	4.50	3.02

N is used in the part number only when a Canadian CRN is required, when a code requirement must be met or material traceability is required. 4:1 safety factor required.

Construction

Tube: Smooth synthetic rubber blend compounded to resist lubricating oil mist
Reinforcement: Multiple plies of spiraled high tensile calendared fabric
Cover: Thick yellow wrapped finish, cut, abrasion, weather & ozone resistant
Operating Temperature: -40°C to 80°C (-40°F to 180°F)
Typical Hose End Couplings:
 (Comes with Clamp or Crimped Sleeve)
 Qlaw™ Quick Acting Claw Couplings (PG 40)
 Thor-Quick Dual Lock Safety Couplings (PG 44)
 BQC Series MacDonald Style Couplings (PG 46)
 Shank Hose Couplings (PG 60)
 Heavy Duty Ground Joint Couplings (PG 88)
 See full compatible couplings list (Pages 30-33)

Thorburn Series (N)16TA

Extra High Pressure Wire Braid Air Hose



Thorburn Series (N)16TA: is a 600 psi (41.4 Bar) steel reinforced air hose designed for the most rugged applications where extra high working pressure, long life and maximum safety are required. Thorburn's 16TA withstands extreme abuse, tugging and pulling found in open pit, underground mining, construction sites and quarries.

Applications:

Jack hammers, air tools and other air operated equipment.

Safety Factor: 3:1

Thorburn Part #	Hose I.D.		Hose O.D.		Design Pressure		Bend Radius		Weight	
	mm	in	mm	in	bar	PSI	mm	in	kg/m	lb/ft
(N)16TA08	12	1/2	26	1.03	68.9	1000	140	6	0.55	0.37
(N)16TA12	20	3/4	33	1.28	55.1	800	210	8	0.73	0.49
(N)16TA16	25	1	39	1.53	55.1	800	280	11	0.98	0.66
(N)16TA20	30	1 1/4	46	1.81	41.4	600	350	14	1.19	0.80
(N)16TA24	40	1 1/2	52	2.06	41.4	600	420	17	1.53	1.03
(N)16TA32	50	2	66	2.59	41.4	600	560	22	2.23	1.51
(N)16TA32A	50	2	70	2.75	55.2	800	560	22	2.23	1.51
(N)16TA40A	65	2 1/2	82	3.23	51.7	750	700	28	3.15	2.12
(N)16TA48A	80	3	93	3.66	41.4	600	840	33	4.55	3.06
(N)16TA64A	100	4	121	4.75	41.4	600	1120	44	6.06	4.07
(N)16TA96A	150	6	175	6.89	34.5	500	1600	63	10.14	6.82

N is used in the part number only when a Canadian CRN is required, when a code requirement must be met or material traceability is required. 4:1 safety factor required.

Construction

Tube: Smooth Synthetic rubber blend compounded to resist lubricating oil mist
Reinforcement: High tensile plated steel wire braid
Cover: Thick yellow wrapped finish, cut, abrasion, weather & ozone resistant
Operating Temperature: -40°C to 80°C (-40°F to 180°F)
Typical Hose End Couplings:
 (Comes with Clamp or Crimped Sleeve)
 Qlaw™ Quick Acting Claw Couplings (PG 40)
 Thor-Quick Dual Lock Safety Couplings (PG 44)
 BQC Series MacDonald Style Couplings (PG 46)
 Shank Hose Couplings (PG 60)
 Heavy Duty Ground Joint Couplings (PG 88)
 See full compatible couplings list (Pages 30-33)

Thorburn Rubber General Purpose Air Hose Assemblies



Thorburn Series (N)22TA “Cold-Flex”

Premium General Purpose Air Hose



Thorburn Series (N)22TA: is a low temperature multi-purpose hose specifically designed and compounded to provide excellent service across a variety of applications Thorburn’s (N)22TA has low temperature flexibility that resists stiffening, cracking, abrasion, oil and weather down to -54°C (-65°F).

Applications:

Arctic conditions for air compressor, air tools, snow making

Safety Factor: 3:1

Thorburn Part #	Hose I.D.		Hose O.D.		Design Pressure		Weight	
	mm	in	mm	in	bar	PSI	kg/m	lb/ft
(N)22TA08	12	1/2	21	0.84	20.7	300	0.52	0.35
(N)22TA12	20	3/4	28	1.12	20.7	300	0.58	0.39
(N)22TA16	25	1	37	1.47	20.7	300	0.78	0.49
(N)22TA20	30	1 1/4	45	1.78	20.7	300	0.91	0.61
(N)22TA24	40	1 1/2	52	2.03	20.7	300	1.24	0.83
(N)22TA32	50	2	64	2.50	20.7	300	1.86	1.25

N is used in the part number only when a Canadian CRN is required, when a code requirement must be met or material traceability is required. 4:1 safety factor required.

Construction

Tube: Specially compounded blend of Nitrile Type A for arctic conditions, smooth oil and fuel resistant
Reinforcement: Multiple plies of high tensile synthetic fabric with static wire to eliminate static charge
Cover: Blue synthetic rubber blend Type A compound for oil resistance, extreme cold weather found arctic conditions

Operating Temperature:
 -54°C to 90°C (-65°F) to (195°F)

Typical Hose End Couplings:
 (Comes with Clamp or Crimped Sleeve)
 Hose Barb Fittings (PG 34)
 Qlaw™ Quick Acting Claw Couplings (PG 40)
 Thor-Quick Dual Lock Safety Couplings (PG 44)
 BQC Series MacDonald Style Couplings (PG 46)
 Industrial Interchange Couplings (PG 50)
 Shank Hose Couplings (PG 60)
 Camlock Quick Couplings (PG 64)
 Heavy Duty Ground Joint Couplings (PG 88)
 See full compatible couplings list (Pages 30-33)

Thorburn Rubber General Purpose Air Hose Assemblies



Thorburn Series (N)110TA “Blow Flex”

EPDM General Purpose Hard Wall Hot Air Blower Hose



Thorburn Series (N)110TA: is specifically designed for rugged outdoor service to withstand the extreme temperatures encountered in transferring hot air in dry bulk transfer. Thorburn’s (N)110TA offers full suction capability, kink resistance and is flexible to ease handling. A static wire is added to dissipate static charge.

Applications:

Tank transport, in plant transfer and offloading of dry bulk materials.

Safety Factor: 3:1

Thorburn Part #	Hose I.D.		Hose O.D.		Design Pressure		Bend Radius		Weight	
	mm	in	mm	in	bar	PSI	mm	in	kg/m	lb/ft
(N)110TA32	50	2	64	2.53	10.3	150	406	16	1.76	1.18
(N)110TA48	80	3	95	3.75	10.3	150	610	24	3.20	2.15
(N)110TA64	100	4	121	4.75	10.3	150	813	32	4.47	3.00

N is used in the part number only when a Canadian CRN is required, when a code requirement must be met or material traceability is required. 4:1 safety factor required.

Construction

- Tube:** Smooth EPDM rubber blend (Type H) for maximum heat resistance
- Reinforcement:** Double steel helical wire to enhance flexibility embedded between plies of spiraled high tensile calendared fabric
- Cover:** Heat, weather and ozone resistant EPDM rubber blend (Type H)
- Operating Temperature:** -40°C to 163°C (-40°F to 325°F)
- Intermittent Temperature:** Up to 175°C (347°F)
- Typical Hose End Couplings:** (Comes with Clamp or Crimped Sleeve)
Shank Hose Couplings (PG 60)
Camlock Quick Couplings (PG 64)
See full compatible couplings list (Pages 30-33)

Thorburn PVC Air Hose Assemblies



Thorburn Series (N)17TA

PVC Multi-Purpose Phthalate Free Hose



Thorburn Series (N)17TA: is a high quality, versatile, multipurpose hose for air, water, low pressure pneumatic and hydraulic systems, lubricating oils, diesel fuel and mild chemical use. Complies with ARPM Class B designation and are specifically formulated from high grade PVC resins that are engineered to be flexible at low temperatures down to -40°C, unlike other PVC hoses, which would become stiff at low temperatures. Thorburn's 17TA PVC air hose is uniquely blended to make the hose look and feel like a comparable rubber hose.

Applications: Lubricating air tools, paint spray stems, In plant freezer applications requiring air or water transfer.

Safety Factor: 3:1

Thorburn Part #	Hose I.D.		Hose O.D.		Design Pressure@70°F		Design Pressure@122°F		Weight	
	mm	in	mm	in	bar	PSI	bar	PSI	kg/m	lb/ft
(N)17TA04	6	1/4	12.7	0.50	13.8	200	12.4	180	0.13	0.09
(N)17TA05	8	5/16	14.2	0.56	13.8	200	12.4	180	0.16	0.14
(N)17TA06	10	3/8	16.0	0.63	13.8	200	8.6	125	0.17	0.12
(N)17TA08	12	1/2	19.1	0.75	13.8	200	6.9	100	0.21	0.45
(N)17TA12	20	3/4	26.2	1.03	10.3	150	6.9	100	0.30	0.24

Color Availability: Red (Standard) (All Sizes), Yellow, Blue, Grey (04, 06, 08, 12, 16), Green (06)

Note: Working pressure decreases as temperature increases.

N is used in the part number only when a Canadian CRN is required, when a code requirement must be met or material traceability is required. 4:1 safety factor required.

Construction

Tube: low temperature PVC blend

Reinforcement: Multiple plies of high tensile spiraled braided fabric

Cover: UV and weather, abrasion resistant low temperature PVC blend

Cover Color: Red (Standard), Yellow (17TAY), Blue (17TAB), Grey (17TAG), Green (17TAGN)

Operating Temperature:

-40°C to 65°C (-40°F to 150°F)

Typical Hose End Couplings:

(Comes with Clamp or Crimped Sleeve)

Hose Barb Fittings (PG 34)

Qlaw™ Quick Acting Claw Couplings (PG 40)

Thor-Quick Dual Lock Safety Couplings (PG 44)

BQC Series MacDonald Style Couplings (PG 46)

Industrial Interchange Couplings (PG 50)

Shank Hose Couplings (PG 60)

Camlock Quick Couplings (PG 64)

Heavy Duty Ground Joint Couplings (PG 88)

See full compatible couplings list (Pages 30-33)

Thorburn Series (N)20TA

PVC/Polyurethane Phthalate Free Hose



Safety Factor: 3:1

Thorburn Part #	Hose I.D.		Hose O.D.		Design Pressure@70°F		Design Pressure@122°F		Weight	
	mm	in	mm	in	bar	PSI	bar	PSI	kg/m	lb/ft
(N)20TA04	6	1/4	12	0.47	20.7	300	13.8	200	0.10	0.07
(N)20TA05	8	5/16	13	0.51	20.7	300	13.8	200	0.13	0.09
(N)20TA06	10	3/8	16	0.67	20.7	300	13.8	200	0.19	0.13
(N)20TA08	12	1/2	20	0.79	20.7	300	13.8	200	0.28	0.18
(N)20TA10	16	5/8	25	0.98	20.7	300	12.1	175	0.22	0.15
(N)20TA12	20	3/4	27	1.06	20.7	300	10.3	150	0.24	0.16

Note: Working pressure decreases as temperature increases.
N is used in the part number only when a Canadian CRN is required, when a code requirement must be met or material traceability is required. 4:1 safety factor required.

Thorburn Series (N)20TA: is an ideal hose for general air and water applications that need to operate at higher temperatures than Thorburn's 17TA hose. Complies with ARPM Class A designation for high oil resistance.

Applications: Transfer of air and water in higher temperature environments, induction welding lines, injection molding coolant lines, transfer of de-ionized water, lubrication/air drop lines, automotive assembly line air hoses, transfer of transmission and power steering fluids, as well as, robotic and lubricated pneumatic air lines. Not recommended for transfer of brake fluid.

Construction

Tube: Abrasion resistant PVC/Polyurethane blend

Reinforcement: High tensile braided fabric

Cover: Smooth, non-marking, pin pricked, highly abrasion resistant PVC/Polyurethane blend

Cover Color: Red (Standard), Yellow (20TAY), Blue (20TAB), Grey (20TAG)

Operating Temperature: -18°C to 85°C (0°F to 185°F)

Typical Hose End Couplings:

(Comes with Clamp or Crimped Sleeve)

Hose Barb Fittings (PG 34)

Qlaw™ Quick Acting Claw Couplings (PG 40)

Thor-Quick Dual Lock Safety Couplings (PG 44)

BQC Series MacDonald Style Couplings (PG 46)

Industrial Interchange Couplings (PG 50)

Shank Hose Couplings (PG 60)

Camlock Quick Couplings (PG 64)

Heavy Duty Ground Joint Couplings (PG 88)

See full compatible couplings list (Pages 30-33)

Thorburn Series (N)21TA

Ultra Flexible PVC Hose



Safety Factor: 3:1

Thorburn Part #	Hose I.D.		Hose O.D.		Design Pressure@70°F		Design Pressure@122°F		Weight	
	mm	in	mm	in	bar	PSI	bar	PSI	kg/m	lb/ft
(N)21TA04	6	1/4	13	0.50	20.7	300	11.0	160	0.12	0.08
(N)21TA06	10	3/8	16	0.63	20.7	300	11.0	160	0.15	0.10
(N)21TA08	12	1/2	20	0.78	20.7	300	11.0	160	0.22	0.15
(N)21TA12	20	3/4	27	1.08	13.8	200	8.3	120	0.37	0.25
(N)21TA16	25	1	35	1.36	13.8	200	8.3	120	0.52	0.35

Note: Working pressure decreases as temperature increases.
N is used in the part number only when a Canadian CRN is required, when a code requirement must be met or material traceability is required. 4:1 safety factor required.

Thorburn Series (N)21TA: is specifically formulated from high grade PVC resins and engineered to be extremely flexible at very low temperatures down to -54°C (-65°F). It is an ideal hose for general air and water applications that operate at lower temperatures. Thorburn's 21TA outperforms other general-purpose PVC and rubber hoses in cold weather air tool applications and is resilient to permanent deformation caused by bending stress. Oil resistance complies with APRM's Class B designation.

Applications: Lubricating air tool applications at low temperatures, such as, in plant freezers requiring air or water service, exterior air hose for use in cold weather where flexibility and handling in tight places are required.

Construction

Tube: Low temperature abrasion resistant PVC compound

Reinforcement: Multiple plies of high tensile spiraled fabric

Cover: Low temperature abrasion resistant PVC compound

Cover Color: Red (Standard), Yellow (21TAY), Blue (21TAB), Orange (21TAO)

Operating Temperature: -54°C to 65°C (-65°F to 150°F)

Typical Hose End Couplings:

(Comes with Clamp or Crimped Sleeve)

Hose Barb Fittings (PG 34)

Qlaw™ Quick Acting Claw Couplings (PG 40)

Thor-Quick Dual Lock Safety Couplings (PG 44)

BQC Series MacDonald Style Couplings (PG 46)

Industrial Interchange Couplings (PG 50)

Shank Hose Couplings (PG 60)

Camlock Quick Couplings (PG 64)

Heavy Duty Ground Joint Couplings (PG 88)

See full compatible couplings list (Pages 30-33)

Thorburn PVC General Purpose Air Hose Assemblies



Thorburn Series (N)18TA

PVC Clear Multi-Purpose Reinforced Phthalate Free Hose

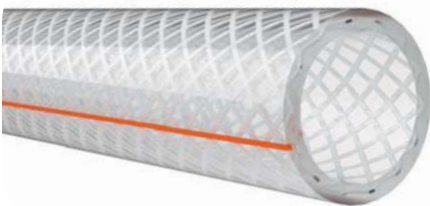

Thorburn Series (N)18TA: is a light weight, clear reinforced PVC hose that is ideal for air breathing lines and pneumatic tools. The hose is made with Phthalate free PVC that is NSF-51 certified and is formulated with applicable FDA, 3A, USDA, NSF, Rohs, USP class VI criteria and is longitudinally reinforced to reduce elongation under pressure. Thorburn 18TA is light weight, self-extinguishing and non-marking.

Applications: Food and beverage dispensing, transfer of deionized water, liquid food products, potable water transfer, air and water lines, air breathing hose lines, pneumatic lines and packaging lines

Safety Factor: 3:1

Thorburn Part #	Hose I.D.		Hose O.D.		Design Pressure@70°F		Design Pressure@122°F		Weight	
	mm	in	mm	in	bar	PSI	bar	PSI	kg/m	lb/ft
(N)18TA03	5	3/16	10	0.38	24	350	14	200	0.06	0.04
(N)18TA04	6	1/4	11	0.44	24	350	14	200	0.09	0.07
(N)18TA05	8	5/16	14	0.53	19	275	11	160	0.11	0.08
(N)18TA06	10	3/8	15	0.59	19	275	10	145	0.13	0.09
(N)18TA08	12	1/2	19	0.75	17	250	9.0	130	0.21	0.15
(N)18TA010	16	5/8	23	0.89	16	225	8.6	125	0.27	0.18
(N)18TA012	20	3/4	26	1.03	14	200	8.6	125	0.33	0.23
(N)18TA016	25	1	33	1.30	10	150	5.7	85	0.45	0.32
(N)18TA020	30	1 1/4	41	1.62	8.6	125	5.2	75	0.82	0.58
(N)18TA024	40	1 1/2	49	1.94	6.9	100	4.5	65	0.98	0.69
(N)18TA032	50	2	63	2.50	5.2	75	3.8	55	1.42	1.00

N is used in the part number only when a Canadian CRN is required, when a code requirement must be met or material traceability is required. 4:1 safety factor required.

Construction

- Tube:** Smooth crystal-clear PVC
 - Reinforcement:** Multiple plies of high tensile braided fabric and a blue or red tracer line for easy identification
 - Cover:** Smooth PVC Clear non-marking
 - Operating Temperature:** 4°C to 65°C (-25°F to 150°F)
 - Typical Hose End Couplings:**
 - (Comes with Clamp or Crimped Sleeve)
 - Hose Barb Fittings (PG 34)
 - Qlaw™ Quick Acting Claw Couplings (PG 40)
 - Thor-Quick Dual Lock Safety Couplings (PG 44)
 - BQC Series MacDonald Style Couplings (PG 46)
 - Industrial Interchange Couplings (PG 50)
 - Shank Hose Couplings (PG 60)
 - Camlock Quick Couplings (PG 64)
 - Heavy Duty Ground Joint Couplings (PG 88)
- See full compatible couplings list (Pages 30-33)*

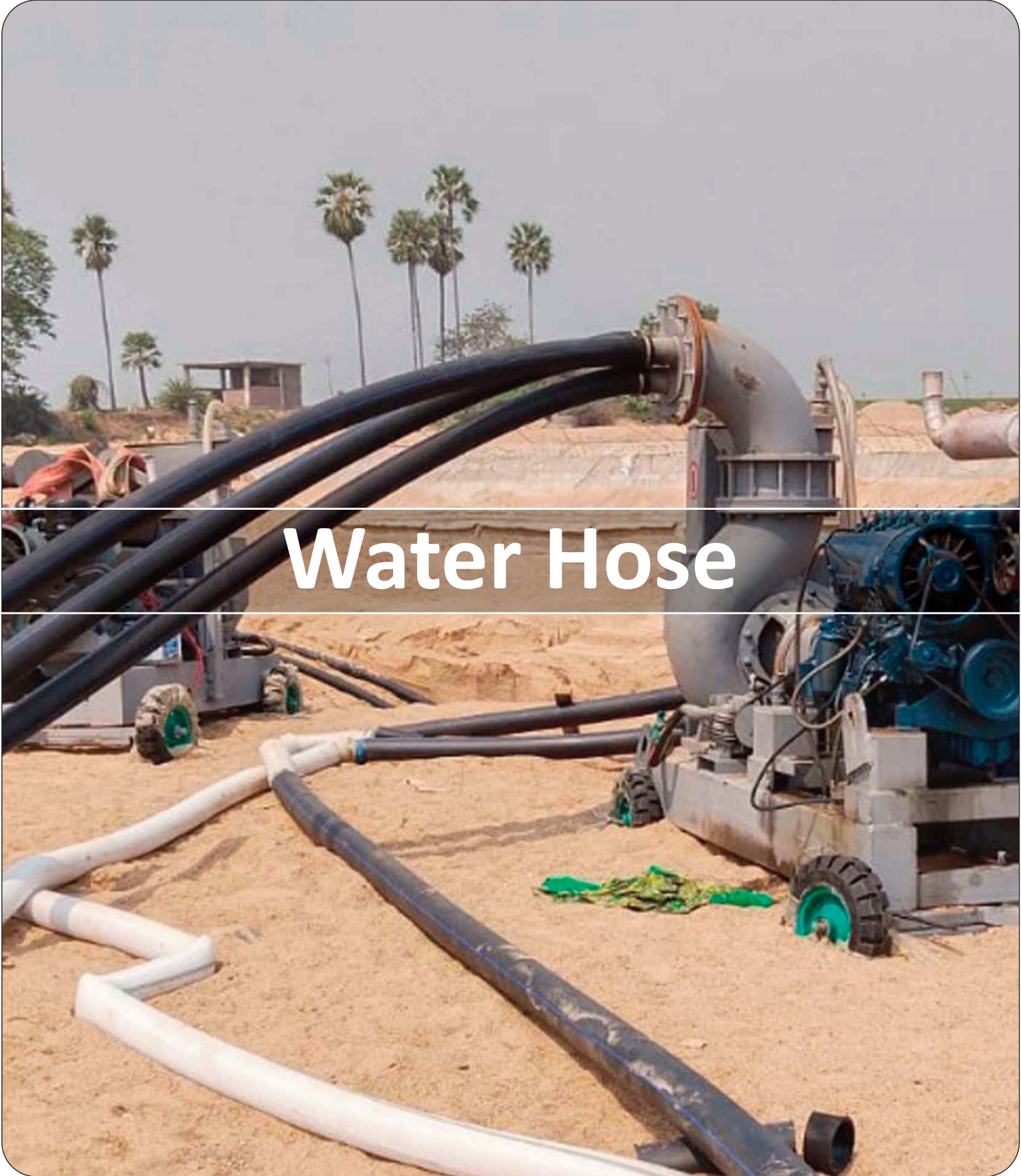

Thorburn Rubber Water Suction-Discharge Hose Assemblies



Thorburn Series (N)21TW

High Pressure Water Discharge Hose



Thorburn Series (N)21TW: is a premium quality, water discharge rubber hose is designed for applications, where extra abrasion resistance or higher working pressures are required. Thorburn's (N)21TW thick rubber cover is designed to withstand abuse from constant dragging or contact with rocky ground as well as providing excellent UV protection.

Applications: Water discharge in construction, mines, quarries and heavy duty rental equipment water discharge.

Safety Factor: 3:1

Thorburn Part #	Hose I.D.		Hose O.D.		Design Pressure		Weight	
	mm	in	mm	in	bar	PSI	kg/m	lb/ft
(N)21TW08A	12	1/2	22	0.9	17	250	0.35	0.25
(N)21TW12A	20	3/4	30	1.2	17	250	0.54	0.38
(N)21TW16A	25	1	37	1.4	14	200	0.71	0.50
(N)21TW20	30	1 1/4	42	1.7	21	300	0.74	0.52
(N)21TW24	40	1 1/2	49	1.9	15	215	0.87	0.61
(N)21TW32	50	2	63	2.3	14	200	1.12	0.79
(N)21TW40	65	2 1/2	76	3.0	14	200	1.75	1.23
(N)21TW48	80	3	89	3.5	14	200	2.06	1.45
(N)21TW64	100	4	114	4.5	17	150	2.70	1.90
(N)21TW80	125	5	140	5.5	17	150	3.41	2.40
(N)21TW96	150	6	165	6.5	9	125	4.05	2.85
(N)21TW128	200	8	217	8.6	9	125	5.87	4.42
(N)21TW160	250	10	271	10.7	9	125	9.10	5.97
(N)21TW192	300	12	322	12.7	7	100	10.88	7.14

N is used in the part number only when a Canadian CRN is required, when a code requirement must be met or material traceability is required. 4:1 safety factor required.

Construction

Tube: Smooth Synthetic Rubber blend

Reinforcement: Multiple layers High tensile calendared fabric

Cover: Black Smooth, weather, ozone, and abrasion resistant synthetic rubber blend

Operating Temperature:

-30°C (-22°F) to 90°C (195°F)

Typical Hose End Couplings:

(Comes with Clamp or Crimped Sleeve)

Shank Hose Couplings (PG 62)

Camlock Quick Couplings (PG 64)

Series TB Bauer Type Lever Couplings (Pg 74)

Series TP Perrot Type Lever Couplings (Pg 78)

Series 70 Couplings for Bolt-On Safety Clamps (Pg 82)

Heavy Duty Ground Joint Couplings (Pg 88)

See full compatible couplings list (Pages 30-33)

Thorburn Series (N)24TW

Heavy Duty Water Suction Hose



Thorburn Series (N)24TW: Is a heavy duty, wire reinforced rubber suction hose, built for rugged and demanding applications, such as, irrigation, surface mining, construction, quarrying, and general water suction service. Thorburn's (N)24TW thick rubber cover is designed to withstand abuse from constant dragging or contact with rocky ground as well as providing excellent UV protection.

Applications: Year around water suction lines, ground water suction lines, heavy construction, municipal, dewatering, mining applications, suction glycol supply lines on portable heating units. Ideal hose for rugged and demanding vacuum truck service.

Safety Factor: 3:1

Thorburn Part #	Hose I.D.		Hose O.D.		Design Pressure		Bend Radius		Weight	
	mm	in	mm	in	bar	PSI	mm	in	kg/m	lb/ft
(N)24TW16	25	1	37	1.4	21	300	152	6	0.71	0.50
(N)24TW20	30	1 1/4	43	1.7	21	300	203	8	0.91	0.61
(N)24TW24	40	1 1/2	49	1.9	17	250	229	9	1.05	0.71
(N)24TW32	50	2	61	2.4	14	200	305	12	1.47	0.99
(N)24TW40	65	2 1/2	75	3.0	14	200	381	15	2.41	1.62
(N)24TW48	80	3	90	3.6	14	200	457	18	2.68	1.80
(N)24TW64	100	4	116	4.6	9	125	610	24	4.21	2.83
(N)24TW80	125	5	142	5.6	7	100	762	30	6.40	4.30
(N)24TW96	150	6	173	6.8	7	100	914	36	9.46	6.35
(N)24TW128	200	8	227	8.9	7	100	1219	48	14.78	9.92
(N)24TW160	250	10	278	10.9	7	100	1524	60	23.59	15.83
(N)24TW192	300	12	330	13.0	7	100	1829	72	28.06	18.82

N is used in the part number only when a Canadian CRN is required, when a code requirement must be met or material traceability is required. 4:1 safety factor required.

Construction

Tube: Smooth synthetic rubber blend

Reinforcement: Heavy wire helix embedded between multi-layers of synthetic calendared fabric

Cover: Black wrapped finish weather and abrasion resistant synthetic rubber blend

Operating Temperature:

-40°C to 82°C (-40°F to 180°F)

Typical Hose End Couplings:

(Comes with Clamp or Crimped Sleeve)

Shank Hose Couplings (PG 62)

Camlock Quick Couplings (PG 64)

Series TB Bauer Type Lever Couplings (Pg 74)

Series TP Perrot Type Lever Couplings (Pg 78)

Series 70 Couplings for Bolt-On Safety Clamps (Pg 82)

Heavy Duty Ground Joint Couplings (Pg 88)

See full compatible couplings list (Pages 30-33)

Thorburn Series (N)224TW

Corrugated Heavy Duty Water Suction Hose



Thorburn Series (N)224TW: Is a corrugated version of Thorburn's series 24TW for added flexibility and maneuverability in tight places. Thorburn's 224TW corrugated thick rugged rubber cover is designed to withstand abuse from constant dragging or contact with rocky ground as well as providing excellent UV protection.

Applications: Year around water suction lines, ground water suction lines, heavy construction, municipal, dewatering, mining applications, suction glycol supply lines on portable heating units. Ideal hose for rugged and demanding vacuum truck service.

Safety Factor: 3:1

Thorburn Part #	Hose I.D.		Hose O.D.		Design Pressure		Bend Radius		Weight	
	mm	in	mm	in	bar	PSI	mm	in	kg/m	lb/ft
(N)224TW24	40	1 1/2	49	1.9	17	150	152	6	0.97	0.65
(N)224TW32	50	2	61	2.4	17	150	203	8	1.56	1.05
(N)224TW48	80	3	89	3.5	17	150	305	12	2.78	1.87
(N)224TW64	100	4	114	4.5	17	150	406	16	3.79	2.55
(N)224TW80	125	5	170	6.7	17	150	508	20	7.57	5.09
(N)224TW96	150	6	185	7.3	17	150	635	25	9.75	6.55
(N)224TW128	200	8	224	8.8	17	150	813	32	12.20	8.20
(N)224TW160	250	10	278	10.9	17	150	1016	40	17.17	11.54
(N)224TW192	300	12	335	13.2	17	150	1219	48	24.66	16.57

N is used in the part number only when a Canadian CRN is required, when a code requirement must be met or material traceability is required. 4:1 safety factor required.

Construction

Tube: Smooth synthetic rubber blend

Reinforcement: Heavy wire helix embedded between multi-layers of high tensile calendared fabric

Cover: Black wrapped finish corrugated for enhanced flexibility, weather and abrasion resistant synthetic rubber blend

Operating Temperature:

-35°C (-31°F) to 100°C (212°F)

Typical Hose End Couplings:

(Comes with Clamp or Crimped Sleeve)

Shank Hose Couplings (PG 62)

Camlock Quick Couplings (PG 64)

Series TB Bauer Type Lever Couplings (Pg 74)

Series TP Perrot Type Lever Couplings (Pg 78)

Series 70 Couplings for Bolt-On Safety Clamps (Pg 82)

Heavy Duty Ground Joint Couplings (Pg 88)

See full compatible couplings list (Pages 30-33)

Thorburn Rubber Sanitary Washdown Hose Assemblies



Thorburn Series (N)26TW/(N)26TWN

Premium Sanitary Wash-Down Hose and Built In Nozzle



| Smooth Tapered Nozzle |

Thorburn Series (N)26TW: is light weight and easy to handle , ideal hose for clean-up and hot water wash-down service in food processing plants, to maintain sanitary conditions. Premium materials give longer service life at high temperatures. (N) 26TWN Hose incorporates an integral built-on smooth tapered rubber nozzle to ensure a good stream for open-ended wash-down.

Applications: Dairies, creameries, meat packaging houses, food processing and bottling plants to maintain sanitary condition

Safety Factor: 3:1

Thorburn Part #	Hose I.D.		Hose O.D.		Design Pressure		Weight	
	mm	in	mm	in	bar	PSI	kg/m	lb/ft
(N)26TW08	12	1/2	25	1.0	21	300	3.81	2.56
(N)26TW12	20	3/4	32	1.3	21	300	4.89	3.28
(N)26TW16	25	1	38	1.5	21	300	5.96	4.00
(N)26TW20	32	1 1/4	45	1.8	21	300	7.42	4.98
(N)26TW24	38	1 1/2	51	2.0	21	300	9.22	6.19

Special Note: Extended exposure to very oily greasy conditions will cause cover to swell and reduce service life. When this is the case, please add suffix N26TWDN/ (N)26TWD for oil resistant tube and cover. N is used in the part number only when a Canadian CRN is required, when a code requirement must be met or material traceability is required. 4:1 safety factor required.

Construction

Tube: EPDM (TYPE N) blend Smooth, heat-resistant synthetic rubber

Reinforcement: Multiple spiral layers of high tensile calendared synthetic fabric

Cover: White smooth , abrasion and heat resistant, non-marking EPDM blend (Type N)

Operating Temperature: -40°C (-40°F) to 93°C (200°F)

Typical Hose End Couplings: (Comes with Clamp or Crimped Sleeve)

- Shank Hose Couplings (PG 62)
- Camlock Quick Couplings (PG 64)
- Series 70 Couplings for Bolt-On Safety Clamps (Pg 82)
- Heavy Duty Ground Joint Couplings (Pg 88)
- See full compatible couplings list (Pages 30-33)

Thorburn Rubber Paper Mill Washdown Hose Assemblies



Thorburn Series (N)27TW/(N)27TWN

Paper Mill Wash-Down Hose and Built In Nozzle



| Smooth Tapered Nozzle |

Thorburn Series (N)27TW: Is a premium quality paper mill wash-down hose that is light weight and easy to handle, ideal hose for clean-up and hot water wash-down service in is in paper mills. It is built with a thick hose wall that offers an optimum balance between weight and kink resistance. The primary consideration for Thorburn (N)27TW hose is kink resistance, so that flow will not be cut off when operators are climbing over catwalks and around tight corners during machinery washdown.

Thorburn Series (N)27TWN: Hose incorporates an integral built-on tapered rubber nozzle to ensure a good stream for open-ended wash-down. Because the nozzle is all rubber and built in, it can be used around machinery without the risk of damage to surfaces or parts that metal fittings or nozzles can cause.

Applications: Paper mill and Industrial Washdown service

Safety Factor: 3:1

Thorburn Part #	Hose I.D.		Hose O.D.		Design Pressure		Weight	
	mm	in	mm	in	bar	PSI	kg/m	lb/ft
(N)27TW08	12	1/2	23	0.9	21	300	3.81	2.56
(N)27TW12	20	3/4	30	1.2	21	300	4.89	3.28
(N)27TW16	25	1	37	1.4	21	300	5.96	4.00
(N)27TW20	32	1 1/4	43	1.7	21	300	7.42	4.98
(N)27TW24	38	1 1/2	52	2.0	21	300	9.22	6.19

Special Note: Also available with oil resistant compounds for use on oil rigs please use part number (N)27TWD/ (N)27TWDN. N is used in the part number only when a Canadian CRN is required, when a code requirement must be met or material traceability is required. 4:1 safety factor required.

Construction

Tube: Smooth, heat-resistant EPDM blend Type (H) rubber maximum resistance to heat and aging

Reinforcement: Multiple layers of high tensile calendared fabric

Cover: Green Abrasion, heat and chemical resistant EPDM Type (H) rubber for maximum resistance to heat and aging

Operating Temperature:
-40°C to 100°C (-40°F to 212°F)

Typical Hose End Couplings:

(Comes with Clamp or Crimped Sleeve)

Shank Hose Couplings (PG 62)

Camlock Quick Couplings (PG 64)

Series 70 Couplings for Bolt-On Safety Clamps (Pg 82)

Heavy Duty Ground Joint Couplings (Pg 88)

See full compatible couplings list (Pages 30-33)

Thorburn PVC Potable Water Hose Assemblies



Thorburn Series (N)118TW

PVC Clear Multi-Purpose Reinforced Phthalate Free Hose

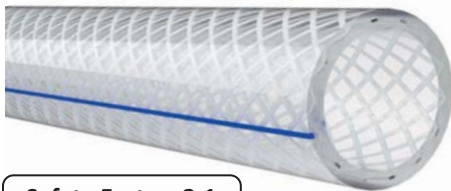

Safety Factor: 3:1

Thorburn Part #	Hose I.D.		Hose O.D.		Design Pressure@70°F		Design Pressure@122°F		Weight	
	mm	in	mm	in	bar	PSI	bar	PSI	kg/m	lb/ft
(N)118TW03	5	3/16	10	0.38	24	350	14	200	0.06	0.04
(N)118TW04	6	1/4	11	0.44	24	350	14	200	0.09	0.07
(N)118TW05	8	5/16	14	0.53	19	275	11	160	0.11	0.08
(N)118TW06	10	3/8	15	0.59	19	275	10	145	0.13	0.09
(N)118TW08	12	1/2	19	0.75	17	250	9.0	130	0.21	0.15
(N)118TW10	16	5/8	23	0.89	16	225	8.6	125	0.27	0.18
(N)118TW12	20	3/4	26	1.03	14	200	8.6	125	0.33	0.23
(N)118TW16	25	1	33	1.30	10	150	5.7	85	0.45	0.32
(N)118TW20	30	1 1/4	41	1.62	8.6	125	5.2	75	0.82	0.58
(N)118TW24	40	1 1/2	49	1.94	6.9	100	4.5	65	0.98	0.69
(N)118TW32	50	2	63	2.50	5.2	75	3.8	55	1.42	1.00

N is used in the part number only when a Canadian CRN is required, when a code requirement must be met or material traceability is required. 4:1 safety factor required.

Thorburn Series (N)118TW: is a clear, light weight, non-toxic, non-conductive, non-marking, silicon free, self-extinguishing multi-purpose PVC hose. The hose is crystal clear so operators can detect flow or product blockage. Thorburn's 118TW is phthalate free PVC that is made of NSF-51, 3A, FDA, compliant materials and is longitudinally reinforced with a colored tracer yarn for identification and reduce elongation under pressure.

Applications: Potable water service requiring NSF-61 compliance, marine drinking lines, beverage dispensing, de-ionized water, food processing, packaging machines, pneumatic and water lines

Construction

Tube: Clear Smooth, Phthalate free PVC

Reinforcement: High tensile spiraled polyester yarn and a longitudinal colored tracer yarn for identification and reduce elongation under pressure

Cover: Crystal Clear Smooth, abrasion and weather resistant PVC, allows for visual confirmation of product flow

Operating Temperature:

-4°C to 65°C (25°F to 149°F)

Typical Hose End Couplings:

(Comes with Clamp or Crimped Sleeve)

Hose Barb Fittings (Pg 34)

Qlaw™ Quick Acting Claw Couplings (Pg 40)

Thor-Quick Dual Lock Safety Couplings (Pg 44)

BQC Series MacDonald Style Couplings (Pg 46)

Industrial Interchange Couplings (Pg 50)

Heavy Duty Ground Joint Couplings (Pg 88)

See full compatible couplings list (Pages 30-33)

Thorburn Series (N)220TW

PVC/Polyurethane Phthalate Free Hose



Safety Factor: 3:1

Thorburn Part #	Hose I.D.		Hose O.D.		Design Pressure@70°F		Design Pressure@122°F		Weight	
	mm	in	mm	in	bar	PSI	bar	PSI	kg/m	lb/ft
(N)220TW04	6	1/4	12	0.47	20.7	300	13.8	200	0.10	0.07
(N)220TW05	8	5/16	13	0.51	20.7	300	13.8	200	0.13	0.09
(N)220TW06	10	3/8	16	0.67	20.7	300	13.8	200	0.19	0.13
(N)220TW08	12	1/2	20	0.79	20.7	300	13.8	200	0.28	0.18
(N)220TW10	16	5/8	25	0.98	20.7	300	12.1	175	0.22	0.15
(N)220TW12	20	3/4	27	1.06	20.7	300	10.3	150	0.24	0.16

Color Availability: Red (Standard) (04, 06, 08, 12), Yellow (04, 06, 08, 12), Blue (04, 06, 08, 12), Grey (04, 06, 08, 12)

N is used in the part number only when a Canadian CRN is required, when a code requirement must be met or material traceability is required. 4:1 safety factor required.

Thorburn Series (N)220TW: is an ideal hose for general water applications that require operating at higher temperature than traditional PVC hoses. Complies with ARPM Class A designation for high oil resistance, as well as RoHS compliant and is made of silicone free materials. The polyurethane cover is extremely abrasion resistant and provides excellent hose coupling retention and flexibility over a wide temperature range.

Applications: Injection molding, coolant lines, de-ionized water transfer, Robotic and pneumatic air lines, automotive assembly line air hoses, lubricated air lines, induction welding tubing lines, transfer of transmission and power steering fluids. Not recommended for transfer of brake fluids.

Construction

Tube: Highly abrasion and cut resistant PVC /Polyurethane blend

Reinforcement: High tensile fabric

Cover: Smooth, non-marking, pin pricked, highly abrasion resistant PVC/Polyurethane blend

Cover Color: Red (Standard), Yellow (220TWY), Blue (220TWB), Grey (220TWG)

Operating Temperature:

-18°C to 85°C (0°F to 185°F)

Typical Hose End Couplings:

(Comes with Clamp or Crimped Sleeve)

Hose Barb Fittings (Pg 34)

Qlaw™ Quick Acting Claw Couplings (Pg 40)

Thor-Quick Dual Lock Safety Couplings (Pg 44)

BQC Series MacDonald Style Couplings (Pg 46)

Industrial Interchange Couplings (Pg 50)

Heavy Duty Ground Joint Couplings (Pg 88)

Thorburn Series (N)221TW

Ultra Flexible PVC Phthalate Free Hose



Safety Factor: 3:1

Thorburn Part #	Hose I.D.		Hose O.D.		Design Pressure@70°F		Design Pressure@122°F		Weight	
	mm	in	mm	in	bar	PSI	bar	PSI	kg/m	lb/ft
(N)221TW04	6	1/4	13	0.50	20.7	300	11.0	160	0.12	0.08
(N)221TW06	10	3/8	16	0.63	20.7	300	11.0	160	0.15	0.10
(N)221TW08	12	1/2	20	0.78	20.7	300	11.0	160	0.22	0.15
(N)221TW12	20	3/4	27	1.08	13.8	200	8.3	120	0.37	0.25
(N)221TW16	25	1	35	1.36	13.8	200	8.3	120	0.52	0.35

Color Availability: Red (Standard) (04, 06, 08), Yellow (04, 06, 08), Blue (04, 06, 08), Orange (12, 16)

N is used in the part number only when a Canadian CRN is required, when a code requirement must be met or material traceability is required. 4:1 safety factor required.

Thorburn Series (N)221TW: is a light weight versatile multi-functional hose compounded from high grade PVC resins and engineered to be extremely flexible at very low temperatures down to -54 °C and is resilient to permanent deformation caused by bending stress. These superior physical properties make it an ideal hose for applications that require easy handling and flexibility, where other PVC hoses would become stiff and impossible to handle. Thorburn's (N)221 TW is oil resistant and complies with APRM's Class B designation, made from silicone free materials and RoHS compliant.

Applications: Plant freezers requiring water service, exterior water hose for use in cold weather where flexibility and handling are required.

Construction

Tube: Smooth PVC with resins blended and designed for flexibility at low temperature

Reinforcement: Multiple plies of high tensile spiraled fabric

Cover: PVC Blended for Low temperature flexibility down 54 deg C. Non -marking pin-pricked cover abrasion resistant PVC compound

Cover Color: Red (Standard), Yellow (221TWY), Blue (221TWB), Orange (221TWO)

Operating Temperature: -54°C to 65°C (-65°F to 150°F)

Typical Hose End Couplings:

(Comes with Clamp or Crimped Sleeve)

Hose Barb Fittings (Pg 34)

Qlaw™ Quick Acting Claw Couplings (Pg 40)

Thor-Quick Dual Lock Safety Couplings (Pg 44)

BQC Series MacDonald Style Couplings (Pg 46)

Industrial Interchange Couplings (Pg 50)

Heavy Duty Ground Joint Couplings (Pg 88)

See full compatible couplings list (Pages 30-33)

Thorburn PVC Water Suction Hose Assemblies



Thorburn Series (N)25TWH

PVC Phthalate Free Water Suction Hose



Thorburn Series (N)25TWH: Is an ideal hose for use in Heavy Duty water suction for construction and mining applications. The clear construction allows for visual confirmation of media flow MSHA Approved (J Series only) for flame -resistance for use in underground mines and RoHS compliant.

Applications: Dewatering, irrigation lines and pumps, drain lines, pumps for trash, rock dusting, agricultural liquid fertilizer (see through construction allows for visual confirmation of material flow).

Safety Factor: 3:1

Thorburn Part #	Hose I.D.		Hose O.D.		Design Pressure		Bend Radius		Weight	
	mm	in	mm	in	bar	PSI	mm	in	kg/m	lb/ft
(N)25TWH12	20	3/4	25	1.0	8	115	76	3	0.31	0.21
(N)25TWH16	25	1	32	1.3	7	100	76	3	0.40	0.27
(N)25TWH20	30	1 1/4	40	1.6	7	100	102	4	0.54	0.36
(N)25TWH24	40	1 1/2	47	1.8	7	100	127	5	0.71	0.48
(N)25TWH32	50	2	60	2.4	7	100	178	7	1.06	0.71
(N)25TWH40	65	2 1/2	73	2.9	5	70	203	8	1.43	0.96
(N)25TWH48	80	3	87	3.4	5	70	254	10	1.86	1.25
(N)25TWH64	100	4	116	4.6	4	60	381	15	2.90	1.95
(N)25TWH96	150	6	172	6.8	3	40	635	25	5.60	3.76
(N)25TWH128	200	8	226	8.9	2	30	762	30	8.93	6.00

Color Availability: Clear (Standard) (12, 16, 20, 24, 32, 40, 48, 64, 96), Blue (16, 20, 24, 32, 48), Orange (16, 24, 32, 40, 48, 64, 96, 128)

N is used in the part number only when a Canadian CRN is required, when a code requirement must be met or material traceability is required. 4:1 safety factor required.

Construction

Tube: Smooth PVC

Reinforcement: Multi-ply of high tensile spiral braid and rigid PVC helix

Cover: Smooth PVC (Sizes 3/4" - 4") for clamping and coupling retention and higher-pressure rating
Convuluted PVC (Sizes 6" - 8") Provides increased hose flexibility

Cover Color: Clear (Standard), Blue (25TWHDB), Orange (25TWHDO)

Operating Temperature:

-4°C to 65°C (-20°F to 150°F)

Typical Hose End Couplings:

(Comes with Clamp or Crimped Sleeve)

Shank Hose Couplings (Pg 62)

Camlock Quick Couplings (Pg 64)

Series TB Bauer Type Lever Couplings (Pg 74)

Series TP Perrot Type Lever Couplings (Pg 78)

Heavy Duty Ground Joint Couplings (Pg 88)

See full compatible couplings list (Pages 30-33)

Thorburn Series (N)255TWHD

PVC Phthalate Free Water Suction Hose



Safety Factor: 3:1

Thorburn Part #	Hose I.D.		Hose O.D.		Design Pressure		Full Vacuum @68°C Hg(in)	Bend Radius		Weight	
	mm	in	mm	in	bar	PSI		mm	in	kg/m	lb/ft
(N)255TWHD24	40	1 1/2	48	1.9	7	100	Full	76	3	0.60	0.40
(N)255TWHD32	50	2	61	2.4	7	100	Full	102	4	1.12	0.75
(N)255TWHD40	65	2 1/2	76	3.0	6	90	Full	152	6	1.47	0.99
(N)255TWHD48	80	3	91	3.6	5	80	Full	178	7	1.99	1.34
(N)255TWHD64	100	4	119	4.7	4	65	Full	279	11	3.20	2.15
(N)255TWHD96	150	6	174	6.9	3	50	Full	457	18	5.60	3.76
(N)255TWHD128	200	8	232	9.1	2	35	Full	610	24	8.81	5.92

N is used in the part number only when a Canadian CRN is required, when a code requirement must be met or material traceability is required. 4:1 safety factor required.

Thorburn Series (N)255TWHD: Is our most durable and resilient liquid suction hose. An ideal hose for use in heavy duty water suction in cold weather conditions down to -40°C. Thorburn's 255TWHD has a corrugated cover for increased flexibility and a static dissipative tube to prevent build-up of static electricity. Rated for full vacuum and is RoHS compliant.

Applications: Pumps, slurry handling and construction dewatering, irrigation lines heavy and duty water suction lines.

Construction

Tube: Smooth, extremely thick PVC for maximum abrasive resistance

Reinforcement: Multiple spirals of high tensile fabric braid with heavy duty PVC helix for full vacuum with integral static dissipative wire

Cover: Black, PVC Convuluted provides increased hose flexibility

Operating Temperature:
-40°C to 65°C (-40°F to 150°F)

Typical Hose End Couplings:
(Comes with Clamp or Crimped Sleeve)

Shank Hose Couplings (PG 62)

Camlock Quick Couplings (PG 64)

Series TB Bauer Type Lever Couplings (Pg 74)

Series TP Perrot Type Lever Couplings (Pg 78)

Heavy Duty Ground Joint Couplings (Pg 88)

Thorburn Series (N)256TWHD

PVC Phthalate Free Heavy Duty Water Suction Hose



Safety Factor: 3:1

Thorburn Part #	Hose I.D.		Hose O.D.		Design Pressure		Full Vacuum @68°C Hg(in)	Bend Radius		Weight	
	mm	in	mm	in	bar	PSI		mm	in	kg/m	lb/ft
(N)256TWHD16	25	1	33	1.3	3.8	55	Full	25	1	0.31	0.21
(N)256TWHD20	30	1 1/4	41	1.6	3.4	50	Full	51	2	0.42	0.28
(N)256TWHD24	40	1 1/2	47	1.9	3.4	50	Full	51	2	0.51	0.34
(N)256TWHD32	50	2	61	2.4	3.4	50	Full	76	3	0.77	0.52
(N)256TWHD40	65	2 1/2	76	3.0	3.1	45	Full	102	4	1.15	0.77
(N)256TWHD48	80	3	93	3.6	3.1	45	Full	152	6	1.76	1.18
(N)256TWHD64	100	4	121	4.8	2.4	35	Full	203	8	2.86	1.92
(N)256TWHD80	125	5	146	5.6	2.4	35	28	305	12	4.39	2.95
(N)256TWHD96	150	6	152	7.0	2.1	30	28	356	14	5.60	3.76
(N)256TWHD128	200	8	233	9.0	2.1	30	28	610	24	8.91	5.99
(N)256TWHD128	250	10	294	11.6	1.7	25	28	991	39	14.49	9.74
(N)256TWHD128	300	12	347	13.6	1.4	20	28	1499	59	19.00	12.77
(N)256TWHD128	350	14	396	15.6	1.2	18	26	2032	80	20.09	13.50
(N)256TWHD128	400	16	450	17.7	0.8	12	24	2413	95	23.81	16.00

N is used in the part number only when a Canadian CRN is required, when a code requirement must be met or material traceability is required. 4:1 safety factor required.

Thorburn Series (N)256TWHD: Is an extremely durable and resilient liquid suction hose with transparent construction allowing for visual conformation of the media. An ideal hose for use in heavy duty water suction in cold weather conditions down to -40°C (sizes above 4" DN 100). Thorburn's 255TWHD has a corrugated cover for increased flexibility Rated for full vacuum and RoHS compliant.

Applications: Fish Suction, Gold Dredging, Pumps, rental and construction dewatering, Pump trash, slurry handling heavy duty water suction, dust collection, irrigation lines drain lines

Construction

Tube: Smooth, thick PVC Blend

Reinforcement: Multiple plies of high tensile fabric braid Rigid PVC helix

Cover: Clear, convuluted PVC for maximum flexibility allows for visual confirmation of material flow

Operating Temperature:
-20°C to 65°C (-4°F to 150°F) (Sizes 1" - 3")
-40°C to 65°C (-40°F to 150°F) (Sizes 4" - 16")

Typical Hose End Couplings:
(Comes with Clamp or Crimped Sleeve)

Shank Hose Couplings (PG 59)

Camlock Quick Couplings (PG 61)

Series TB Bauer Type Lever Couplings (Pg 74)

Series TP Perrot Type Lever Couplings (Pg 78)

Heavy Duty Ground Joint Couplings (Pg 88)

See full compatible couplings list (Pages 30-33)



Steam Hose

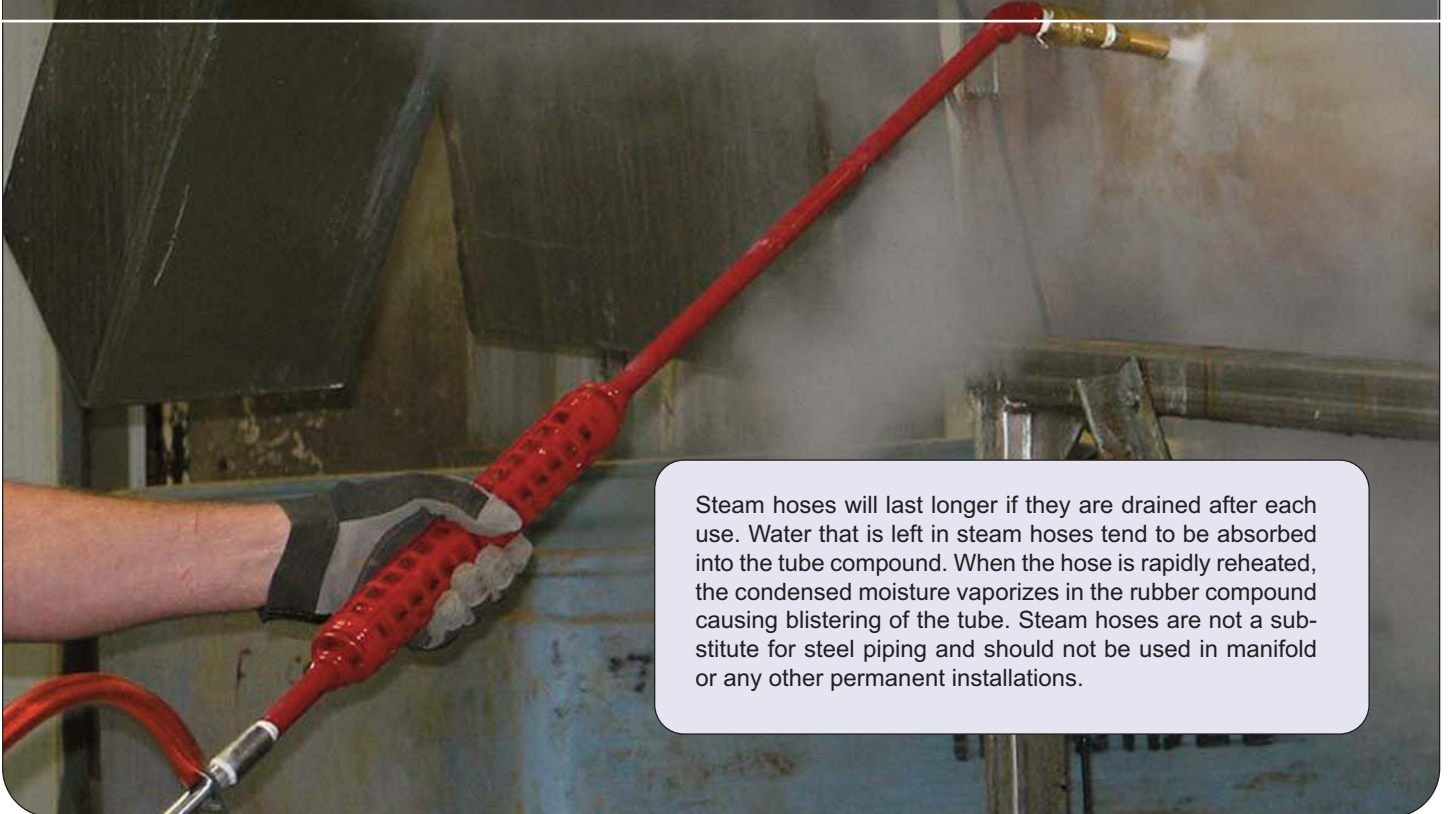

Steam hoses will last longer if they are drained after each use. Water that is left in steam hoses tend to be absorbed into the tube compound. When the hose is rapidly reheated, the condensed moisture vaporizes in the rubber compound causing blistering of the tube. Steam hoses are not a substitute for steel piping and should not be used in manifold or any other permanent installations.

Thorburn Series (N)30TS

Rubber Steam Hose



Thorburn Series (N)30TS: is an EPDM blend versatile steam hose that has excellent ozone, heat resistance and is less permeable to gases than other synthetic rubbers. These characteristics provide for improved life expectancy. It is constructed with high tensile plated steel reinforcement suitable for conveying saturated and superheated steam up to 250 PSI (17 Bar). It's rugged, light weight design allows the operator to handle and maneuver the hose in tight places. Thorburn's 30TS EPDM Type "H" compound does not age quickly and it absorbs less steam. When steam hoses cycle from hot to cold, the steam that has been absorbed into hose tube condenses and when it is suddenly re-heated, the water can vaporize and trigger "popcorning" of the tube resulting in rapid tube deterioration and hose failure.

Applications: Construction sites, foundries, steel mills, shipyards, chemical plants and refineries.

Safety Factor: 10:1

Thorburn Part #	Hose I.D.		Hose O.D.		Design Pressure		Bend Radius		Weight	
	mm	in	mm	in	bar	PSI	mm	in	kg/m	lb/ft
(N)30TS08	12.7	1/2	25.4	1.0	17	250	178	7	0.54	0.36
(N)30TS12	19.1	3/4	31.7	1.3	17	250	241	10	0.75	0.50
(N)30TS16	25.4	1	38.1	1.5	17	250	305	12	1.04	0.70
(N)30TS20	31.8	1 1/4	47.0	1.9	17	250	419	17	1.51	1.01
(N)30TS24	38.1	1 1/2	54.9	2.2	17	250	508	20	1.86	1.25
(N)30TS32	50.8	2	67.8	2.7	17	250	635	25	2.46	1.65
(N)30TS48	76.2	3	96.8	3.8	17	250	762	30	4.72	3.17

N is used in the part number only when a Canadian CRN is required, when a code requirement must be met or material traceability is required. 4:1 safety factor required. **Special note:** Larger diameters available on request. Please specify non-conductive application with order.

Construction

Tube: Black EPDM Type H blend with high resistance to heat, aging and popcorning with carbon black added to make the tube electrically conductive
Reinforcement: Dual high tensile wire braids with textile anchor braid providing a 10:1 safety factor with enhanced bending flexibility
Cover: Red EPDM Type "H" blend, abrasion, weather, and heat resistant, pin-pricked to prevent blistering and defuse gas build-up between the cover and the carcass.
Operating Temperature:
 Saturated: -40°C to 208°C (-40°F to 406°F)
Typical Hose End Couplings:
 (Comes with Clamp or Crimped Sleeve)
 Series 80 Couplings for Bolt-On Safety Clamps (Pg 86)
 Heavy Duty Ground Joint Couplings (pg 88)
 See full compatible couplings list (Pages 30-33)

Thorburn Series (N)32TS/(N)33TS

Rubber Steam Hose



Thorburn Series (N)32TS: Is a textile reinforced steam hose designed for use in applications where steel reinforcement is not suitable because of electrical conductivity. Larger diameters available.

Thorburn Series (N)33TS: Is a completely non-conductive version of Thorburn's (N)32TS (must be specified before order placement). 400 PSI pressure rating for hot water service.

Applications: Electro-plating operations, around electric arc steel furnace, electrical maintenance shops, thawing, wash-down at paper mills and food plants and super-heated and saturated steam or high temperature water applications.

Safety Factor: 10:1

Thorburn Part #	Hose I.D.		Hose O.D.		Design Pressure		Weight	
	mm	in	mm	in	bar	PSI	kg/m	lb/ft
(N)32TS08	12.7	1/2	24.4	1.0	7	100	0.60	0.40
(N)32TS12	19.1	3/4	32.0	1.3	7	100	0.79	0.53
(N)32TS16	25.4	1	39.1	1.5	7	100	0.98	0.66
(N)32TS20	31.8	1 1/4	46.0	1.8	7	100	1.30	0.87
(N)32TS24	38.0	1 1/2	52.0	2.1	7	100	1.39	0.93
(N)32TS32	50.8	2	65.0	2.6	7	100	1.76	1.18
(N)32TS48	76.2	3	94.0	3.7	7	100	3.39	2.27

N is used in the part number only when a Canadian CRN is required, when a code requirement must be met or material traceability is required. 4:1 safety factor required. **Special note:** Larger diameters available on request. Please specify non-conductive application with order ((N)33TS).

Construction

Tube: EPDM Type H blend Compounded for high resistance to heat aging and the effects of popcorning
Reinforcement: Multiple plies of high tensile calendared fiberglass textile cords
(N)32TS Cover: Red, EPDM Type "H" blend, abrasion, weather and heat resistant, pin-pricked to prevent blistering and defuse gas build-up between the cover and the carcass
(N)33TS Cover: White EPDM Type "H" blend
Operating Temperature:
 Saturated: -40°C (-40°F) to 170°C (338°F)
Typical Hose End Couplings:
 (Comes with Clamp or Crimped Sleeve)
 Series 80 Couplings for Bolt-On Safety Clamps (Pg 86)
 Heavy Duty Ground Joint Couplings (pg 88)
 See full compatible couplings list (Pages 30-33)

Thorburn Standard Couplings For Air, Water & Steam Hoses

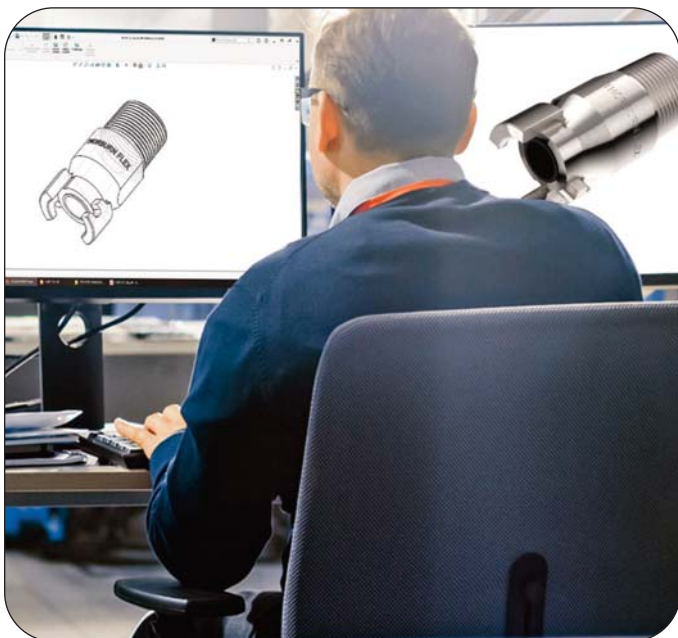

Thorburn's commitment to development is reinforced through the use of CAD (Computer Aided Design) system technology and finite engineering analysis, which permits us to pinpoint potential critical areas and provide sound engineered solutions.

Precision Machined Hose Couplings

Thorburn Flex is an innovative manufacturer of precision machined hose couplings and adapters and are the culmination of Thorburn's precision machine coupling business unit. Our tradition of excellence in engineering is enhanced by innovations in employee involvement and production technology designed to achieve total quality and customer satisfaction. Through our combined efforts, we have designed systems for administration, engineering, quality control and manufacturing, based on what we know and learn from each customer and application.

- NDE to ASME Section V Radiography, Dye Penetrant, Ultrasonic, Magnetic Particles.
- Burst testing up to 150,000 psi
- Impulse testing up to 10,000 psi at 400°F

Hose Coupling Manufacturing



CNC Programming



Precision Machining



Coupling Assembly



Inspection



Impulse Testing



Proof Testing







Suggested Thorburn Couplings For Air, Water & Steam Hoses

Standard Couplings		Air Hose										
		(N)10TA	(N)11TANC	(N)14TA	(N)15TA	(N)16TA	(N)17TA	(N)20TA	(N)21TA	(N)110TA	(N)22TA	(N)18TA
	Brass Hose Barb Fittings Pg - 34	✓	✓				✓	✓	✓		✓	✓
	Qlaw™ Quick Acting Claw Couplings Pg - 40	✓	✓	✓	✓	✓	✓	✓	✓		✓	✓
	Thor-Quick Dual Lock Safety Hose Couplings Pg - 44	✓	✓	✓	✓	✓	✓	✓	✓		✓	✓
	Series BQC MacDonald Style Quick Action Couplings Pg - 47	✓	✓	✓	✓	✓	✓	✓	✓		✓	✓
	Industrial Series TD Interchange Single Shut-Off Valve Couplings Pg - 50	✓	✓				✓	✓	✓		✓	✓
	Series T43 Ring Lock Single Shut-Off Valve Couplings Pg - 54	✓	✓									
	Air Hose Swivels and Manifolds Pg - 58	✓	✓									
	Combination Hose Shank Couplings - Low Pressure Pg - 60	✓	✓	✓	✓	✓	✓			✓	✓	

Industrial Hose Assemblies | Standard Hose Couplings

Water Hose													Steam Hose			
(N)21TW	(N)24TW	(N)224TW	(N)26TWN	(N)26TWN	(N)27TW	(N)27TWN	(N)21TW	(N)118TW	(N)220TW	(N)221TW	(N)25TWH	(N)255TWH	(N)256TWH	(N)30TS	(N)32TS	(N)33TS
								✓	✓	✓						
								✓	✓	✓						
								✓	✓	✓						
								✓	✓	✓						
								✓	✓	✓						
✓	✓	✓	✓	✓	✓						✓	✓	✓			

Suggested Thorburn Couplings For Air, Water & Steam Hoses

Standard Couplings		Air Hose										
		(N)10TA	(N)11TANC	(N)14TA	(N)15TA	(N)16TA	(N)17TA	(N)20TA	(N)21TA	(N)110TA	(N)22TA	(N)18TA
	Shank Couplings for Water Discharge and Suction Hose Pg - 62	✓	✓	✓	✓	✓	✓			✓	✓	
	Quick Acting Camlock Couplings Pg - 64	✓	✓				✓			✓	✓	
	Series TB Bauer Type B Style Lever Couplings Pg - 74											
	Series TP Perrot Style Lever Couplings Pg - 78											
	Series 70BSC EN 14420 / DIN2817 Couplings for Bolt-On Safety Clamps Pg - 82											
	Series 80BSC EN 14423 / DIN2826 Couplings for Bolt-On Safety Clamps Pg - 86											
	Heavy Duty Ground Joint Couplings Pg - 88	✓	✓	✓	✓	✓	✓	✓	✓		✓	✓

Industrial Hose Assemblies | Standard Hose Couplings

Water Hose													Steam Hose			
(N)21TW	(N)24TW	(N)224TW	(N)26TWN	(N)26TWN	(N)27TW	(N)27TWN	(N)21TW	(N)118TW	(N)220TW	(N)221TW	(N)25TWHHD	(N)255TWHHD	(N)256TWHHD	(N)30TS	(N)32TS	(N)33TS
✓	✓	✓	✓	✓	✓						✓	✓	✓			
✓	✓	✓	✓	✓	✓						✓	✓	✓			
✓	✓	✓									✓	✓	✓			
✓	✓	✓									✓	✓	✓			
✓	✓	✓	✓	✓	✓											
														✓	✓	✓
✓	✓	✓						✓	✓	✓	✓	✓	✓	✓	✓	✓

Thorburn Series HB - Hose Barb Couplings

Thorburn’s Series HB hose barb fittings are designed for use in low pressure air and water service. Thorburn barbed fittings consist of a number of cylindrical ridges which grip the inside of the hose or tubing. Thorburn Series HB hose barb fittings have many advantages and are widely used in low pressure industrial applications such as, air, gas and all fluid media. Thorburn Series HB hose barbed fittings can be used with synthetic and natural rubber hose. Thorburn Series HB hose barbs must be secured by means of a ferrule or clamp and if installed correctly will be leak tight and remain on the hose assembly up to and including the hose assembly burst pressure.



Style - HB-MP | Male Insert



Note: Requires a clamp or ferrule to secure Thorburn Series HB fittings to a hose (See Pages 98 to 110)

Part Number		Nominal Hose I.D.		NPTF Thread
316SS	Brass	Inch	mm	Inch
HB-02X02-MP-S6	HB-02X02-MP-BB	1/8	3	1/8
HB-02X04-MP-S6	HB-02X04-MP-BB	1/8	3	1/4
HB-03X02-MP-S6	HB-03X02-MP-BB	3/16	5	1/8
HB-03X04-MP-S6	HB-03X04-MP-BB	3/16	5	1/4
HB-04X02-MP-S6	HB-04X02-MP-BB	1/4	6	1/8
HB-04X04-MP-S6	HB-04X04-MP-BB	1/4	6	1/4
HB-04X06-MP-S6	HB-04X06-MP-BB	1/4	6	3/8
HB-04X10-MP-S6	HB-04X10-MP-BB	1/4	6	1/2
HB-05X02-MP-S6	HB-05X02-MP-BB	5/16	8	1/8
HB-05X04-MP-S6	HB-05X04-MP-BB	5/16	8	1/4
HB-05X06-MP-S6	HB-05X06-MP-BB	5/16	8	3/8
HB-06X02-MP-S6	HB-06X02-MP-BB	3/8	10	1/8
HB-06X04-MP-S6	HB-06X04-MP-BB	3/8	10	1/4
HB-06X06-MP-S6	HB-06X06-MP-BB	3/8	10	3/8
HB-06X08-MP-S6	HB-06X08-MP-BB	3/8	10	1/2
HB-06X12-MP-S6	HB-06X12-MP-BB	3/8	10	3/4
HB-08X04-MP-S6	HB-08X04-MP-BB	1/2	12	1/4
HB-08X06-MP-S6	HB-08X06-MP-BB	1/2	12	3/8
HB-08X08-MP-S6	HB-08X08-MP-BB	1/2	12	1/2
HB-08X12-MP-S6	HB-08X12-MP-BB	1/2	12	3/4
HB-10X06-MP-S6	HB-10X06-MP-BB	5/8	16	3/8
HB-10X08-MP-S6	HB-10X08-MP-BB	5/8	16	1/2
HB-10X12-MP-S6	HB-10X12-MP-BB	5/8	16	3/4
HB-12X08-MP-S6	HB-12X08-MP-BB	3/4	20	1/2
HB-12X12-MP-S6	HB-12X12-MP-BB	3/4	20	3/4
HB-16X12-MP-S6	HB-16X12-MP-BB	1	25	3/4
HB-16X16-MP-S6	HB-16X16-MP-BB	1	25	1
HB-20X12-MP-S6	HB-20X12-MP-BB	1 1/4	30	3/4
HB-20X16-MP-S6	HB-20X16-MP-BB	1 1/4	30	1

Thorburn Series HB - Hose Barb Couplings

Style - HB-MP45 | Male Insert 45° Elbow



Note: Requires a clamp or ferrule to secure Thorburn Series HB fittings to a hose (See Pages 98 to 110)

Part Number		Nominal Hose I.D.		NPTF Thread
316SS	Brass	Inch	mm	Inch
HB-04X02-MP45-S6	HB-04X02-MP45-BB	1/4	6	1/8
HB-04X04-MP45-S6	HB-04X04-MP45-BB	1/4	6	1/4
HB-06X02-MP45-S6	HB-06X02-MP45-BB	3/8	10	1/8
HB-06X04-MP45-S6	HB-06X04-MP45-BB	3/8	10	1/4
HB-06X06-MP45-S6	HB-06X06-MP45-BB	3/8	10	3/8
HB-08X04-MP45-S6	HB-08X04-MP45-BB	1/2	12	1/4
HB-08X06-MP45-S6	HB-08X06-MP45-BB	1/2	12	3/8
HB-08X08-MP45-S6	HB-08X08-MP45-BB	1/2	12	1/2

Style - HB-MP90 | Male Insert 90° Elbow



Note: Requires a clamp or ferrule to secure Thorburn Series HB fittings to a hose (See Pages 98 to 110)

Part Number		Nominal Hose I.D.		NPTF Thread
316SS	Brass	Inch	mm	Inch
HB-03X02-MP90-S6	HB-03X02-MP90-BB	3/16	5	1/8
HB-04X02-MP90-S6	HB-04X02-MP90-BB	1/4	6	1/8
HB-04X04-MP90-S6	HB-04X04-MP90-BB	1/4	6	1/4
HB-04X06-MP90-S6	HB-04X06-MP90-BB	1/4	6	3/8
HB-05X02-MP90-S6	HB-05X02-MP90-BB	5/16	8	1/8
HB-05X04-MP90-S6	HB-05X04-MP90-BB	5/16	8	1/4
HB-05X06-MP90-S6	HB-05X06-MP90-BB	5/16	8	3/8
HB-06X02-MP90-S6	HB-06X02-MP90-BB	3/8	10	1/8
HB-06X04-MP90-S6	HB-06X04-MP90-BB	3/8	10	1/4
HB-06X06-MP90-S6	HB-06X06-MP90-BB	3/8	10	3/8
HB-08X04-MP90-S6	HB-08X04-MP90-BB	1/2	12	1/4
HB-08X10-MP90-S6	HB-08X10-MP90-BB	1/2	12	3/8
HB-08X08-MP90-S6	HB-08X08-MP90-BB	1/2	12	1/2
HB-10X06-MP90-S6	HB-10X06-MP90-BB	5/8	16	3/8
HB-10X08-MP90-S6	HB-10X08-MP90-BB	5/8	16	1/2
HB-12X08-MP90-S6	HB-12X08-MP90-BB	3/4	20	1/2
HB-12X12-MP90-S6	HB-12X12-MP90-BB	3/4	20	3/4
HB-16X12-MP90-S6	HB-16X12-MP90-BB	1	25	3/4
HB-16X16-MP90-S6	HB-16X16-MP90-BB	1	25	1

Thorburn Series HB - Hose Barb Couplings

Style - HB-MS | Male 45° SAE



Note: Requires a clamp or ferrule to secure Thorburn Series HB fittings to a hose (See Pages 98 to 110)

Part Number		Nominal Hose I.D.		UNF Thread
316SS	Brass	Inch	mm	Inch
HB-03X03-MS-S6	HB-03X03-MS-BB	3/16	5	7/16 - 20
HB-04X04-MS-S6	HB-04X04-MS-BB	1/4	6	7/16 - 20
HB-05X05-MS-S6	HB-05X05-MS-BB	5/16	8	1/2 - 20
HB-06X06-MS-S6	HB-06X06-MS-BB	3/8	10	5/8 - 18
HB-06X08-MS-S6	HB-06X08-MS-BB	3/8	10	3/4 - 16
HB-08X08-MS-S6	HB-08X08-MS-BB	1/2	12	3/4 - 16

Style - HB-FSX | Female 45° SAE - 37° JIC Dual Angle Seat, 2 Piece Swivel



Note: Requires a clamp or ferrule to secure Thorburn Series HB fittings to a hose (See Pages 98 to 110)

Part Number		Nominal Hose I.D.		UNF Thread
316SS	Brass	Inch	mm	Inch
HB-03X04-FSX-S6	HB-03X04-FSX-BB	3/16	5	7/16 - 20
HB-04X04-FSX-S6	HB-04X04-FSX-BB	1/4	6	7/16 - 20
HB-05X05-FSX-S6	HB-05X05-FSX-BB	5/16	8	1/2 - 20
HB-06X12-FSX-S6	HB-06X12-FSX-BB	3/8	10	3/4 - 16
HB-08X12-FSX-S6	HB-08X12-FSX-BB	1/2	12	3/4 - 16
HB-08X10-FSX-S6	HB-08X10-FSX-BB	1/2	12	7/8 - 14

Thorburn Series HB - Hose Barb Couplings

Style - HB-FP | Solid Female Insert



Note: Requires a clamp or ferrule to secure Thorburn Series HB fittings to a hose (See Pages 98 to 110)

Part Number		Nominal Hose I.D.		NPSM Thread
316SS	Brass	Inch	mm	Inch
HB-02X02-FP-S6	HB-02X02-FP-BB	1/8	3	1/8
HB-02X04-FP-S6	HB-02X04-FP-BB	1/8	3	1/4
HB-03X02-FP-S6	HB-03X02-FP-BB	3/16	5	1/8
HB-03X04-FP-S6	HB-03X04-FP-BB	3/16	5	1/4
HB-04X02-FP-S6	HB-04X02-FP-BB	1/4	6	1/8
HB-04X04-FP-S6	HB-04X04-FP-BB	1/4	6	1/4
HB-04X06-FP-S6	HB-04X06-FP-BB	1/4	6	3/8
HB-05X02-FP-S6	HB-05X02-FP-BB	5/16	8	1/8
HB-05X04-FP-S6	HB-05X04-FP-BB	5/16	8	1/4
HB-05X06-FP-S6	HB-05X06-FP-BB	5/16	8	3/8
HB-06X02-FP-S6	HB-06X02-FP-BB	3/8	10	1/8
HB-06X04-FP-S6	HB-06X04-FP-BB	3/8	10	1/4
HB-06X06-FP-S6	HB-06X06-FP-BB	3/8	10	3/8
HB-06X08-FP-S6	HB-06X08-FP-BB	3/8	10	1/2
HB-08X04-FP-S6	HB-08X04-FP-BB	1/2	12	1/4
HB-08X06-FP-S6	HB-08X06-FP-BB	1/2	12	3/8
HB-08X08-FP-S6	HB-08X08-FP-BB	1/2	12	1/2
HB-12X12-FP-S6	HB-12X12-FP-BB	3/4	20	3/4
HB-16X12-FP-S6	HB-16X12-FP-BB	1	25	3/4
HB-16X16-FP-S6	HB-16X16-FP-BB	1	25	1

Style - HB-FS | Female Swivel Gasket Seat Type



Note: Requires a clamp or ferrule to secure Thorburn Series HB fittings to a hose (See Pages 98 to 110)

Part Number		Nominal Hose I.D.		NPSM Thread
316SS	Brass	Inch	mm	Inch
HB-02X02-FS-S6	HB-02X02-FS-BB	1/8	3	1/8
HB-03X02-FS-S6	HB-03X02-FS-BB	3/16	5	1/8
HB-03X04-FS-S6	HB-03X04-FS-BB	3/16	5	1/4
HB-04X02-FS-S6	HB-04X02-FS-BB	1/4	6	1/8
HB-04X04-FS-S6	HB-04X04-FS-BB	1/4	6	1/4
HB-04X06-FS-S6	HB-04X06-FS-BB	1/4	6	3/8
HB-05X04-FS-S6	HB-05X04-FS-BB	5/16	8	1/4
HB-06X04-FS-S6	HB-06X04-FS-BB	3/8	10	1/4
HB-06X06-FS-S6	HB-06X06-FS-BB	3/8	10	3/8
HB-06X08-FS-S6	HB-06X08-FS-BB	3/8	10	1/2
HB-08X06-FS-S6	HB-08X06-FS-BB	1/2	12	3/8
HB-08X08-FS-S6	HB-08X08-FS-BB	1/2	12	1/2
HB-12X12-FS-S6	HB-12X12-FS-BB	3/4	20	3/4

Thorburn Series HB - Hose Barb Couplings

Style - HB-BSX | Female Swivel
Ball Seat - Swivel Nut (NSPM)



Note: Requires a clamp or ferrule to secure Thorburn Series HB fittings to a hose (See Pages 98 to 110)

Part Number		Nominal Hose I.D.		NPSM Thread
316SS	Brass	Inch	mm	Inch
HB-02X02-BSX-S6	HB-02X02-BSX-BB	1/8	3	1/8
HB-03X02-BSX-S6	HB-03X02-BSX-BB	3/16	5	1/8
HB-03X04-BSX-S6	HB-03X04-BSX-BB	3/16	5	1/4
HB-04X02-BSX-S6	HB-04X02-BSX-BB	1/4	6	1/8
HB-04X04-BSX-S6	HB-04X04-BSX-BB	1/4	6	1/4
HB-04X06-BSX-S6	HB-04X06-BSX-BB	1/4	6	3/8
HB-05X04-BSX-S6	HB-05X04-BSX-BB	5/16	8	1/4
HB-05X06-BSX-S6	HB-05X06-BSX-BB	5/16	8	3/8
HB-06X04-BSX-S6	HB-06X04-BSX-BB	3/8	10	1/4
HB-06X06-BSX-S6	HB-06X06-BSX-BB	3/8	10	3/8
HB-06X08-BSX-S6	HB-06X08-BSX-BB	3/8	10	1/2
HB-08X06-BSX-S6	HB-08X06-BSX-BB	1/2	12	3/8
HB-08X08-BSX-S6	HB-08X08-BSX-BB	1/2	12	1/2
HB-12X12-BSX-S6	HB-12X12-BSX-BB	3/4	20	3/4

Style - HB-HM | Hose Barb Menders



Note: Requires a clamp or ferrule to secure Thorburn Series HB fittings to a hose (See Pages 98 to 110)

Part Number		Nominal Hose I.D.	
316SS	Brass	Inch	mm
HB-02-HM-S6	HB-02-HM-BB	1/8	3
HB-03-HM-S6	HB-03-HM-BB	3/16	5
HB-04-HM-S6	HB-04-HM-BB	1/4	6
HB-05-HM-S6	HB-05-HM-BB	5/16	8
HB-06-HM-S6	HB-06-HM-BB	3/8	10
HB-08-HM-S6	HB-08-HM-BB	1/2	12
HB-10-HM-S6	HB-10-HM-BB	5/8	16
HB-12-HM-S6	HB-12-HM-BB	3/4	20
HB-16-HM-S6	HB-16-HM-BB	1	25

Thorburn Series HB - Hose Barb Couplings

Style - HB-HM90 | Hose Barb Mender 90° Elbow



Part Number		Nominal Hose I.D.	
316SS	Brass	Inch	mm
HB-04-HM90-S6	HB-04-HM90-BB	1/4	6
HB-05-HM90-S6	HB-05-HM90-BB	5/16	8
HB-06-HM90-S6	HB-06-HM90-BB	3/8	10
HB-08-HM90-S6	HB-08-HM90-BB	1/2	12

Note: Requires a clamp or ferrule to secure Thorburn Series HB fittings to a hose (See Pages 98 to 110)

Style - HB-HMT | Hose Barb Mender Tee



Part Number		Nominal Hose I.D.	
316SS	Brass	Inch	mm
HB-03-HMT-S6	HB-03-HMT-BB	3/16	5
HB-04-HMT-S6	HB-04-HMT-BB	1/4	6
HB-05-HMT-S6	HB-05-HMT-BB	5/16	8
HB-06-HMT-S6	HB-06-HMT-BB	3/8	10
HB-08-HMT-S6	HB-08-HMT-BB	1/2	12
HB-10-HMT-S6	HB-10-HMT-BB	5/8	16
HB-12-HMT-S6	HB-12-HMT-BB	3/4	20

Note: Requires a clamp or ferrule to secure Thorburn Series HB fittings to a hose (See Pages 98 to 110)

Qlaw™ Quick Acting Claw Coupling System | Type B Canada/US



Thorburn's Qlaw™ couplings are designed for use with air, water, oil and other media where connections must be made quickly or often. Specially designed for quick acting coupling with washer seal. Thorburn's Qlaw™ coupling must be used with a safety clip to assure the claws will not be accidentally disconnected. Safety clips also guarantee the claw couplings are properly connected as the pin will not go through holes in the coupling halves until the couplings are locked in place. Only a single safety pin is required to secure connection against accidental disconnection. Thorburn's Qlaw™ quick acting claw coupling system when connected with the proper clamp or crimped ferrule will remain connected up to and including the burst pressure of the hose assembly.

Symmetric Coupling System

The two symmetrical half couplings have two or four claws each, which are connected by pushing them together and rotating the claws to form a seal.

Insert Type: Serrated insert with safety collar

Working Pressure: 10 bar (150 psi) for all sizes

Recommended Clamps: Claw Clamps (Type B), Crimp Ring, Worm Gear Clamps, 2 Bolt Saddle Clamps

Style 27 | Hose Shank with safety collar and safety pin holes - 2 Lug Type



Maleable Iron/Plated Part #	Bronze Part #	Stainless Part #	Hose ID		Claw Distance Internal mm	Claw Distance External mm
			mm	in		
TQ2704-MP	TQ2704-BR	-	6	1/4	41	62
TQ2706-MP	TQ2706-BR	-	10	3/8	41	62
TQ2708-MP	TQ2708-BR	27I08-S6	13	1/2	41	62
TQ2710-MP	TQ2710-BR	-	16	5/8	41	62
TQ2712-MP	TQ2712-BR	27I12-S6	19	3/4	41	62
TQ2716-MP	TQ2716-BR	27I16-S6	25	1	41	62

Note: Requires a clamp or ferrule to secure Thorburn Style 27 fittings to a hose (See Pages 98 to 110)

European (Type A), Australian (Type S) couplings available upon request. **NOT** to be used with steam applications.

Qlaw™ Quick Acting Claw Coupling System | Type B Canada/US

Style 29 | NPT Male with safety pin holes - 2 Lug Type



Maleable Iron/Plated	Bronze	Stainless	NPT Thread Size		Claw Distance Internal	Claw Distance External
Part #	Part #	Part #	in		mm	mm
TQ2904-MP	TQ2904-BR	-	1/4 - 18		41	62
TQ2906-MP	TQ2906-BR	-	3/8 - 18		41	62
TQ2908-MP	TQ2908-BR	29I08-S6	1/2 - 14		41	62
TQ2910-MP	TQ2910-BR	-	5/8 - 14		41	62
TQ2912-MP	TQ2912-BR	29I12-S6	3/4 - 14		41	62
TQ2916-MP	TQ2916-BR	29I16-S6	1 - 11 1/2		41	62

European (Type A), Australian (Type S) couplings available upon request.
NOT to be used with steam applications.

Style 28 | NPT Female with safety pin holes - 2 Lug Type



Maleable Iron/Plated	Bronze	Stainless	NPT Thread Size		Claw Distance Internal	Claw Distance External
Part #	Part #	Part #	in		mm	mm
TQ2804-MP	TQ2804-BR	-	1/4 - 18		41	62
TQ2806-MP	TQ2806-BR	-	3/8 - 18		41	62
TQ2808-MP	TQ2808-BR	28I08-S6	1/2 - 14		41	62
TQ2810-MP	TQ2810-BR	-	5/8 - 14		41	62
TQ2812-MP	TQ2812-BR	28I12-S6	3/4 - 14		41	62
TQ2816-MP	TQ2816-BR	28I16-S6	1 - 11 1/2		41	62

European (Type A), Australian (Type S) couplings available upon request

Style 33 | Blank Cap with safety pin holes - Complete with seal - 2 Lug Type



Maleable Iron/Plated	Bronze	Stainless	Head Size		Claw Distance Internal	Claw Distance External
Part #	Part #	Part #	DN	in	mm	mm
TQ33-MP	TQ33-BR	-	40	1 1/2	41	62

European (Type A), Australian (Type S) couplings available upon request.
NOT to be used with steam applications.

Qlaw™ Quick Acting Claw Coupling System | Type B Canada/US

Style 30 | Hose Shank with safety collar and safety pin holes - 4 Lug Type



Maleable Iron/Plated	Bronze	Stainless	Hose ID		Claw Distance Internal	Claw Distance External
Part #	Part #	Part #	mm	in	mm	mm
TQ3020-MP	TQ3020-BR	-	32	1 1/4	41	62
TQ3024-MP	TQ3024-BR	-	38	1 1/2	41	62
TQ3032-MP	TQ3032-BR	TQ3032-S6	51	2	41	62

European (Type A), Australian (Type S) couplings available upon request.
NOT to be used with steam applications.

Note: Requires a clamp or ferrule to secure Thorburn Style 30 fittings to a hose (See Pages 98 to 110)

Style 31 | NPT Female with safety pin holes - 4 Lug Type



Maleable Iron/Plated	Bronze	Stainless	NPT Thread Size	Claw Distance Internal	Claw Distance External
Part #	Part #	Part #	in	mm	mm
TQ3120-MP	TQ3120-BR	-	1 1/4 - 1 1/2	41	62
TQ3124-MP	TQ3124-BR	-	1 1/2 - 1 1/2	41	62
TQ3132-MP	TQ3132-BR	TQ3132-S6	2 - 1 1/2	41	62

European (Type A), Australian (Type S) couplings available upon request.
NOT to be used with steam applications.

Style 32 | Three way connector with safety pin holes - Complete with seal



Maleable Iron/Plated	Bronze	Stainless	Hose ID		Claw Distance Internal	Claw Distance External
Part #	Part #	Part #	DN	in	mm	mm
TQ32-MP	TQ32-BR	-	40	1 1/2	41	62

European (Type A), Australian (Type S) couplings available upon request

Qlaw™ Quick Acting Claw Coupling System | Type B Canada/US

Style 35 | Seal (NBR)



NBR	DN	
	mm	in
TQ35	6	1/4

Style 36 | Standard Safety Pin - Zinc Plated



Zinc Plated
Part #
TQ36

Style 37 | Laynards



Synthetic Cord	Stainless Steel
Part #	Part #
TQ37	TQ37-S6

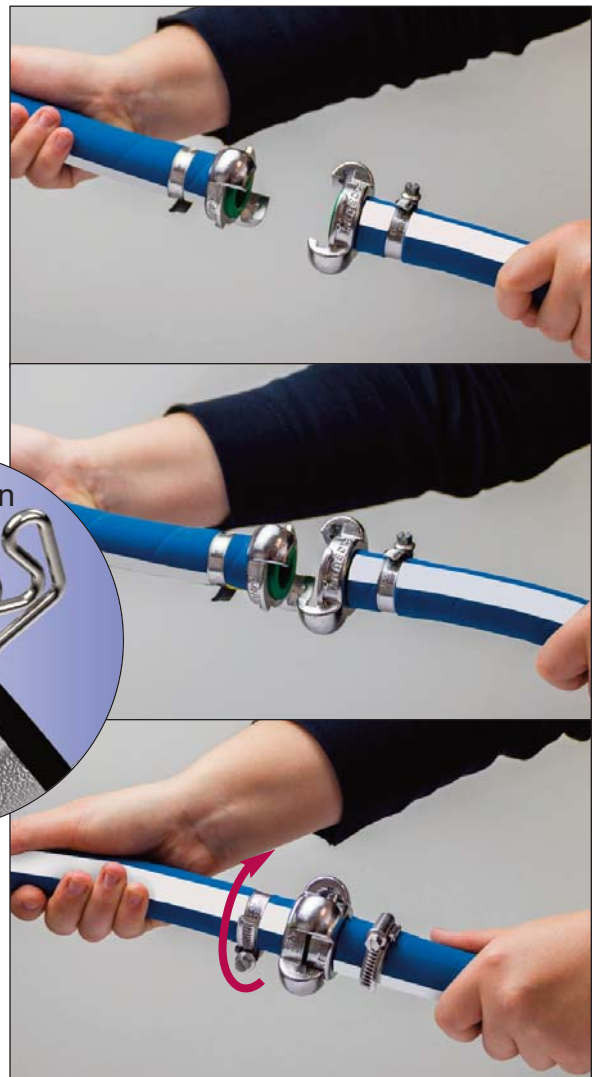

Twist to connect / disconnect

Thor-Quick Dual Lock Safety Hose Couplings | 1/2 inch Body Series



Thorburn Thor-Quick Dual Lock Safety Hose Couplings are used primarily on air or water hose where a safer, more durable coupling is needed. Thor-Quick couplings are suitable for 300 psi with a 3:1 safety factor, and will permit full flow when coupled and are designed to safely handle greater pressures than universal quick acting couplings. Thor-Quick are designed to provide maximum safety against unintentional disconnection where users must pull the sleeve back while simultaneously rotating the fitting in order to disconnect.

Features

- Dual locking safety "fingers" prevent accidental disconnect
- Full flow design
- Thor-Quick are fully interchangeable within each size range
- Meets OSHA safety standards
- Available in plated steel or brass material, 316SS on special order
- Optional locking key prevents sleeve retraction

Design Pressure: 20 bar (300 psi) on all sizes

Operating Temperature: -40°C to 121°C (-40°F to 250°F)

Style - TQMP | Male NPT Pipe Plug

Must be used with locking sleeve Couplings



Thorburn Part #	Body Size		NPT Thread Size	Material
	in	mm	in	
TQMP06-CP	1/2	12	3/8	Plated Steel
TQMP08-CP	1/2	12	1/2	Plated Steel
TQMP08-BB	1/2	12	1/2	Brass
TQMP12-CP	1/2	12	3/4	Plated Steel
TQMP12-BB	1/2	12	3/4	Brass
TQMP16-CP	1/2	12	1	Plated Steel
TQMP16-BB	1/2	12	1	Brass

Style TQFP | Female NPT Pipe Plug

Must be used with locking sleeve Couplings



Thorburn Part #	Body Size		NPT Thread Size	Material
	in	mm	in	
TQFP06-CP	1/2	12	3/8	Plated Steel
TQFP08-CP	1/2	12	1/2	Plated Steel
TQFP08-BB	1/2	12	1/2	Brass
TQFP12-CP	1/2	12	3/4	Plated Steel
TQFP12-BB	1/2	12	3/4	Brass
TQFP16-CP	1/2	12	1	Plated Steel
TQFP16-BB	1/2	12	1	Brass

Thor-Quick Dual Lock Safety Hose Couplings | 1/2 inch Body Series

Style TQHB-LS | Hose End Barb Coupler with Locking Sleeve



Note: Requires a clamp or ferrule to secure Thorburn Style TQHB-LS fittings to a hose (See Pages 98 to 110)

Thorburn Part #	Body Size		Hose Stem Size		Material
	in	mm	in	mm	
TQHB-LS06-CP	1/2	12	3/8	10	Plated Steel
TQHB-LS08-CP	1/2	12	1/2	12	Plated Steel
TQHB-LS08-BB	1/2	12	1/2	12	Brass
TQHB-LS12-CP	1/2	12	3/4	20	Plated Steel
TQHB-LS12-BB	1/2	12	3/4	20	Brass
TQHB-LS16-CP	1/2	12	1	25	Plated Steel
TQHB-LS16-BB	1/2	12	1	25	Brass

Style TQMP-LS | Male NPT Pipe Thread Coupler with Locking Sleeve



Thorburn Part #	Body Size		NPT Thread Size	Material
	in	mm	in	
TQMP-LS06-CP	1/2	12	3/8	Plated Steel
TQMP-LS08-CP	1/2	12	1/2	Plated Steel
TQMP-LS12-CP	1/2	12	3/4	Plated Steel

Style TQFP-LS | Female NPT Pipe Thread Coupler with Locking Sleeve



Thorburn Part #	Body Size		NPT Thread Size	Material
	in	mm	in	
TQFP-LS08-CP	1/2	12	1/2	Plated Steel
TQFP-LS12-CP	1/2	12	3/4	Plated Steel

Replacement Gaskets



Thorburn Part #	Material
T855206D	Buna N
T452963I	F.K.M.

Locking Key



Thorburn Part #	Material
T855231LK	Steel

Locking Key fits 1/2 inch body coupler with locking sleeve

Thorburn Series BQC MacDonald Style Quick Action Couplings



Thorburn Series BQC quick action couplings are interchangeable with MacDonald couplings and are safe and reliable, allowing effortless separation without the risk of accidental disconnection. They are designed for high pressure compressed air or inert gas and are widely used in oil refineries, chemical plants and nitrogen service. Bayonet style couplings can also be used with pneumatic tools and for fire hose reel service where safety is a prime concern.

Features

- The male coupling half is available with a hose stem (HM), Female (inside) thread (IM) and Male (outside) thread (OM)
- The female plug half is available with a hose stem (HF), Female (inside) thread (IF and Male (outside) thread (OF)
- Couplings and plugs are made from plated steel, Standard (brass or stainless steel are available with special order)
- Threads are BSPT as standard (API and NPT available with special order)
- Couplings and plugs of all sizes interchange with each other
- Working pressure hose stems, 17 bar (247 psi) for all sizes. Couplers and plugs, 70 bar (1015 psi) for all sizes
- Seals are made of oil resistant nitrile with a temperature range of -30°C to 100°C
- Made of Plated Steel (Standard). Brass and 316 Stainless Steel available on special order

Style TBQC-HM | Male Hose Stem



Can connect to TBQC-OF & TBQC-IF Plugs. Can connect to Style TBQC-HF when connecting two hoses together. Maximum Design Pressure: 17 bar (247 psi) for all sizes. Requires a clamp or ferrule to secure fittings to a hose. (See Pages 98 to 110)

Thorburn Part #	Size	
	in	mm
TBQC-HM-04-CP	1/4	6
TBQC-HM-06-CP	3/8	10
TBQC-HM-08-CP	1/2	12
TBQC-HM-12-CP	3/4	20
TBQC-HM-16-CP	1	25

Style TBQC-HF | Female Hose Stem



Can connect to TBQC-OM & TBQC-IM Plugs. Can connect to Style TBQC-HM when connecting two hoses together. Maximum Design Pressure: 17 bar (247 psi) for all sizes. Requires a clamp or ferrule to secure fittings to a hose. (See Pages 98 to 110)

Thorburn Part #	Size	
	in	mm
TBQC-HF-04-CP	1/4	6
TBQC-HF-06-CP	3/8	10
TBQC-HF-08-CP	1/2	12
TBQC-HF-12-CP	3/4	20
TBQC-HF-16-CP	1	25

Thorburn Series BQC MacDonald Style Quick Action Couplings

Style TBQCB-OM | Male BSPT Coupler



Maximum Design Pressure: 70 bar (1015 psi) for all sizes.

Thorburn Part #	Size		BSPT Thread Size
	in	mm	in
TBQCB-OM-04-CP	1/4	6	1/4-19
TBQCB-OM-06-CP	3/8	10	3/8-19
TBQCB-OM-08-CP	1/2	12	1/2-14
TBQCB-OM-12-CP	3/4	20	3/4-14
TBQCB-OM-16-CP	1	25	1-11

Style TBQC-OM | Male NPT Coupler



Maximum Design Pressure: 70 bar (1015 psi) for all sizes.

Thorburn Part #	Size		NPT Thread Size
	in	mm	in
TBQC-OM-04-CP	1/4	6	1/4-18
TBQC-OM-06-CP	3/8	10	3/8-18
TBQC-OM-08-CP	1/2	12	1/2-14
TBQC-OM-12-CP	3/4	20	3/4-14
TBQC-OM-16-CP	1	25	1-11 1/2

Style TBQCB-OF | Male BSPT Plug



Maximum Design Pressure: 70 bar (1015 psi) for all sizes.

Thorburn Part #	Size		BSPT Thread Size
	in	mm	in
TBQCB-OF-04-CP	1/4	6	1/4-19
TBQCB-OF-06-CP	3/8	10	3/8-19
TBQCB-OF-08-CP	1/2	12	1/2-14
TBQCB-OF-12-CP	3/4	20	3/4-14
TBQCB-OF-16-CP	1	25	1-11

Thorburn Series BQC MacDonald Style Quick Action Couplings

Style TBQC-OF | Male NPT Plug



Thorburn Part #	Size		NPT Thread Size
	in	mm	in
TBQC-OF-04-CP	1/4	6	1/4-18
TBQC-OF-06-CP	3/8	10	3/8-18
TBQC-OF-08-CP	1/2	12	1/2-14
TBQC-OF-12-CP	3/4	20	3/4-14
TBQC-OF-16-CP	1	25	1-11 1/2

Maximum Design Pressure: 70 bar (1015 psi) for all sizes.

Style TBQCB-IM | Female BSPT Coupler



Thorburn Part #	Size		BSPT Thread Size
	in	mm	in
TBQCB-IM-04-CP	1/4	6	1/4-19
TBQCB-IM-06-CP	3/8	10	3/8-19
TBQCB-IM-08-CP	1/2	12	1/2-14
TBQCB-IM-12-CP	3/4	20	3/4-14
TBQCB-IM-16-CP	1	25	1-11

Maximum Design Pressure: 70 bar (1015 psi) for all sizes.

Style TBQC-IM | Female NPT Coupler



Thorburn Part #	Size		NPT Thread Size
	in	mm	in
TBQC-IM-04-CP	1/4	6	1/4-18
TBQC-IM-06-CP	3/8	10	3/8-18
TBQC-IM-08-CP	1/2	12	1/2-14
TBQC-IM-12-CP	3/4	20	3/4-14
TBQC-IM-16-CP	1	25	1-11 1/2

Maximum Design Pressure: 70 bar (1015 psi) for all sizes.

Thorburn Series BQC MacDonald Style Quick Action Couplings

Style TBQCB-IF | Female BSPT Plug



Thorburn Part #	Size		BSPT Thread Size
	in	mm	in
TBQCB-IF-04-CP	1/4	6	1/4-19
TBQCB-IF-06-CP	3/8	10	3/8-19
TBQCB-IF-08-CP	1/2	12	1/2-14
TBQCB-IF-12-CP	3/4	20	3/4-14
TBQCB-IF-16-CP	1	25	1-11

Maximum Design Pressure: 70 bar (1015 psi) for all sizes.

Style TBQCB-IF | Female NPT Plug



Thorburn Part #	Size		NPT Thread Size
	in	mm	in
TBQC-IF-04-CP	1/4	6	1/4-18
TBQC-IF-06-CP	3/8	10	3/8-18
TBQC-IF-08-CP	1/2	12	1/2-14
TBQC-IF-12-CP	3/4	20	3/4-14
TBQC-IF-16-CP	1	25	1-11 1/2

Maximum Design Pressure: 70 bar (1015 psi) for all sizes.

Thorburn Series BQC MacDonald Connections

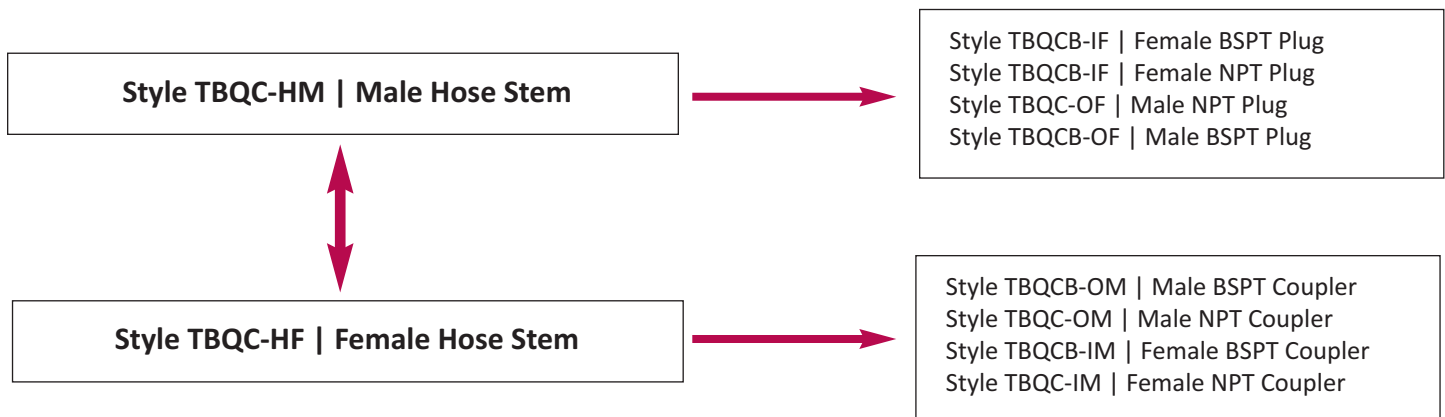

Thorburn Series TD Industrial Interchange Couplings

Thorburn Series TD single shut-off couplings have a valve built into the female coupler (Socket) but not the male connector (Plug). The valve automatically opens when the male connector is mated with or inserted into the female coupler. Thorburn Series TD valve automatically closes when the male nipple/plug is removed. This feature helps keep the system pressurized. For air service only. Thorburn Series TD interchanges with other mil-C4109F/A-A-59439 quick couplings.

Pressure Rating: 21 bar (300 PSI)

Safety Factor: 3:1 (all sizes)

Temperature Range: -40°C to 121°C (-40°F to 250°F)



Style - TDCP-HB | Standard Hose Barb - Plug



Note: Requires a clamp or ferrule to secure Thorburn Style TDCP-HB fittings to a hose (See Pages 98 to 110)

Part #	Body Size	Hose ID	Flow Rating @100PSI	Material
	in	in	CFM	
TDCP-HB0404-CP	1/4	1/4	37	Plated Steel
TDCP-HB0405-CP	1/4	5/16	37	Plated Steel
TDCP-HB0406-CP	1/4	3/8	37	Plated Steel
TDCP-HB0604-CP	3/8	1/4	70	Plated Steel
TDCP-HB0606-CP	3/8	3/8	70	Plated Steel
TDCP-HB0608-CP	3/8	1/2	70	Plated Steel
TDCP-HB0806-CP	1/2	3/8	150	Plated Steel
TDCP-HB0808-CP	1/2	1/2	150	Plated Steel
TDCP-HB0812-CP	1/2	3/4	150	Plated Steel
TDCP-HB1208-CP	3/4	1/2	200	Plated Steel
TDCP-HB1212-CP	3/4	3/4	200	Plated Steel
TDCP-HB1216-CP	3/4	1	200	Plated Steel
TDCP-HB0404-BB	1/4	1/4	37	Brass
TDCP-HB0406-BB	1/4	3/8	37	Brass
TDCP-HB0404-S6	1/4	1/4	37	303SS
TDCP-HB0606-S6	3/8	3/8	70	303SS
TDCP-HB0808-S6	1/2	1/2	150	303SS

Style - TDCP-PHB | Push-On Hose Barb - Plug



Part #	Body Size	Hose ID	Flow Rating @100PSI	Material
	in	in	CFM	
DCP-PHB0404-BB	1/4	1/4	37	Brass
DCP-PHB0406-BB	1/4	3/8	37	Brass
DCP-PHB0604-CP	3/8	1/4	70	Plated Steel
DCP-PHB0606-CP	3/8	3/8	70	Plated Steel

Note: Requires a clamp or ferrule to secure Thorburn Style TDCP-PHB fittings to a hose (See Pages 95 to 107)

Thorburn Series TD Industrial Interchange Couplings

Style - TDCP-MP | Male Pipe Thread - Plug



Part #	Body Size	NPT Thread Size	Flow Rating @100PSI	Material
	in	in	CFM	
TDCP-MP0402-CP	1/4	1/8	37	Plated Steel
TDCP-MP0404-CP	1/4	1/4	37	Plated Steel
TDCP-MP0406-CP	1/4	3/8	37	Plated Steel
TDCP-MP0604-CP	3/8	1/4	70	Plated Steel
TDCP-MP0606-CP	3/8	3/8	70	Plated Steel
TDCP-MP0608-CP	3/8	1/2	70	Plated Steel
TDCP-MP0806-CP	1/2	3/8	150	Plated Steel
TDCP-MP0808-CP	1/2	1/2	150	Plated Steel
TDCP-MP0812-CP	1/2	3/4	150	Plated Steel
TDCP-MP1208-CP	3/4	1/2	200	Plated Steel
TDCP-MP1212-CP	3/4	3/4	200	Plated Steel
TDCP-MP1216-CP	3/4	1	200	Plated Steel
TDCP-MP0402-BB	1/4	1/8	37	Brass
TDCP-MP0404-BB	1/4	1/4	37	Brass
TDCP-MP0406-B	1/4	3/8	37	Brass
TDCP-MP0404-S3	1/4	1/4	37	303SS
TDCP-MP0606-S3	3/8	3/8	70	303SS
TDCP-MP0808-S3	1/2	1/2	150	303SS

Style - TDCP-FP | Female Pipe Thread - Plug



Part #	Body Size	NPT Thread Size	Flow Rating @100PSI	Material
	in	in	CFM	
TDCP-FP0402-CP	1/4	1/8	37	Plated Steel
TDCP-FP0404-CP	1/4	1/4	37	Plated Steel
TDCP-FP0406-CP	1/4	3/8	37	Plated Steel
TDCP-FP0604-CP	3/8	1/4	70	Plated Steel
TDCP-FP0606-CP	3/8	3/8	70	Plated Steel
TDCP-FP0608-CP	3/8	1/2	70	Plated Steel
TDCP-FP0806-CP	1/2	3/8	150	Plated Steel
TDCP-FP0808-CP	1/2	1/2	150	Plated Steel
TDCP-FP0812-CP	1/2	3/4	150	Plated Steel
TDCP-FP1208-CP	3/4	1/2	200	Plated Steel
TDCP-FP1212-CP	3/4	3/4	200	Plated Steel
TDCP-FP1216-CP	3/4	1	200	Plated Steel
TDCP-FP0404-BB	1/4	1/4	37	Brass
TDCP-FP0406-BB	1/4	3/8	37	Brass
TDCP-FP0404-S3	1/4	1/4	37	303SS
TDCP-FP0606-S3	3/8	3/8	70	303SS
TDCP-FP0808-S3	1/2	1/2	150	303SS

Thorburn Series TD Industrial Interchange Couplings

Style - TDC-HB | Standard Hose Barb - Coupler



Part #	Body Size	Hose ID	Flow Rating @100PSI	Material
	in	in	CFM	
TDC-HB0404-BB	1/4	1/4	37	Brass
TDC-HB0405-BB	1/4	5/16	37	Brass
TDC-HB0406-BB	1/4	3/8	37	Brass
TDC-HB0604-CP	3/8	1/4	70	Plated Steel
TDC-HB0606-CP	3/8	3/8	70	Plated Steel
TDC-HB0608-CP	3/8	1/2	70	Plated Steel
TDC-HB0806-CP	1/2	3/8	150	Plated Steel
TDC-HB0808-CP	1/2	1/2	150	Plated Steel
TDC-HB0812-CP	1/2	3/4	150	Plated Steel
TDC-HB1208-BB*	3/4	1/2	200	Brass
TDC-HB1212-BB*	3/4	3/4	200	Brass
TDC-HB1216-BB*	3/4	1	200	Brass
TDC-HB0404-S3	1/4	1/4	37	303SS
TDC-HB0606-S3	3/8	3/8	70	303SS
TDC-HB0808-S3	1/2	1/2	150	303SS

* 3/4 inch couplers are automatic sleeve

Style - TDC-PHB | Push-On Hose Barb - Coupler



Part #	Body Size	Hose ID	Flow Rating @100PSI	Material
	in	in	CFM	
TDC-PHB0404-BB	1/4	1/4	37	Brass
TDC-PHB0406-BB	1/4	3/8	37	Brass
TDC-PHB0604-CP	3/8	1/4	70	Plated Steel
TDC-PHB0606-CP	3/8	3/8	70	Plated Steel

Note: Requires a clamp or ferrule to secure Thorburn Style TDC-PHB fittings to a hose (See Pages 98 to 110)

Thorburn Series TD Industrial Interchange Couplings

Style - TDC-MP | Male Pipe Thread - Coupler



Part #	Body Size	NPT Thread Size	Flow Rating @100PSI	Material
	in	in	CFM	
TDC-MP0402-BB	1/4	1/8	37	Brass
TDC-MP0404-BB	1/4	1/4	37	Brass
TDC-MP0406-BB	1/4	3/8	37	Brass
TDC-MP0604-CP	3/8	1/4	70	Plated Steel
TDC-MP0606-CP	3/8	3/8	70	Plated Steel
TDC-MP0608-CP	3/8	1/2	70	Plated Steel
TDC-MP0806-CP	1/2	3/8	150	Plated Steel
TDC-MP0808-CP	1/2	1/2	150	Plated Steel
TDC-MP0812-CP	1/2	3/4	150	Plated Steel
TDC-MP1208-BB*	3/4	1/2	200	Brass
TDC-MP1212-BB*	3/4	3/4	200	Brass
TDC-MP1216-BB*	3/4	1	200	Brass
TDC-MP0404-S3	1/4	1/4	37	303SS
TDC-MP0606-S3	3/8	3/8	70	303SS
TDC-MP0808-S3	1/2	1/2	150	303SS

* 3/4 inch couplers are automatic sleeve

Style - TDC-FP | Female Pipe Thread - Coupler



Part #	Body Size	NPT Thread Size	Flow Rating @100PSI	Material
	in	in	CFM	
TDC-FP0402-BB	1/4	1/8	37	Brass
TDC-FP0404-BB	1/4	1/4	37	Brass
TDC-FP0406-BB	1/4	3/8	37	Brass
TDC-FP0604-CP	3/8	1/4	70	Plated Steel
TDC-FP0606-CP	3/8	3/8	70	Plated Steel
TDC-FP0608-CP	3/8	1/2	70	Plated Steel
TDC-FP0806-CP	1/2	3/8	150	Plated Steel
TDC-FP0808-CP	1/2	1/2	150	Plated Steel
TDC-FP0812-CP	1/2	3/4	150	Plated Steel
TDC-FP1208-BB*	3/4	1/2	200	Brass
TDC-FP1212-BB*	3/4	3/4	200	Brass
TDC-FP1216-BB*	3/4	1	200	Brass
TDC-FP0404-S3	1/4	1/4	37	303SS
TDC-FP0606-S3	3/8	3/8	70	303SS
TDC-FP0808-S3	1/2	1/2	150	303SS

* 3/4 inch couplers are automatic sleeve

Thorburn Series T43 Ring Lock Single Shut-Off Valve Couplings



Thorburn Series T43 Ring Lock Single Shut-Off Valve Couplings have a check valve in one half, usually the socket half and no valve in the mating half referred to as plug. It is quick to connect and disconnect without the use of a tool. Thorburn Ring Lock Single Shut-Off Valve Couplings are normally installed with the valved half on the pressure side of the circuit to provide automatic shut-off flow when the coupling is disconnected. When connected, the passage opens to allow air to flow through and when disconnected, the valve within the socket remains closed. This coupling design is normally used in pneumatic compressed air systems and breathing hose applications.

Pressure Rating: T43-04: 20 bar (300 psi) T43-06: 20 bar (300 psi)	Flow Capacity: T43-04: 48 ‡Ac T43-06: 80 ‡Ac
---	---

‡ Air flow (scfm with 5 psi pressure drop and 100 psig inlet pressure)

Standard Materials

Coupler: Brass, 316SS, **Valve:** 316SS, **Plug:** Brass, 316SS

Seal: Buna N (Code B), EPDM (Code E),

Fluoroelastomer (FKM) (Code V)

Perfluoroelastomer (FFKM) (Code K)

Accessories: Dust Cap, Dust Plug

Features

- High flow capacity
- Push to connect
- Will not disconnect when the hose is dragged
- Locking sleeve disconnects with 20° rotation

Applications

- Air breathing hose assemblies
- Ship yards
- General pneumatics
- Mining
- Marine

Thorburn Series T43 Ring Lock Single Shut-Off Valve Couplings

Style T43C04-MP | Male NPT - Valved Coupler - 1/4" Body



Thorburn Part #		Thread Size
316 Stainless Steel	Brass	in
T43C04-MP-X-04-S6	T43C04-MP-X-04-BR	1/4 - 18 NPTF
T43C04-MP-X-06-S6	T43C04-MP-X-06-BR	3/8 - 18 NPTF
T43C04-MP-X-08-S6	T43C04-MP-X-08-BR	1/2 - 14 NPTF
T43C04-MP-X-12-S6	T43C04-MP-X-12-BR	3/4 - 14 NPTF

X = Seal Material - (E) EPDM, (B) BUNA-N, (V) FKM, (K) FFKM

Style T43C04-FP | Female NPT - Valved Coupler - 1/4" Body



Thorburn Part #		Thread Size
316 Stainless Steel	Brass	in
T43C04-FP-X-04-S6	T43C04-FP-X-04-BR	1/4 - 18 NPTF
T43C04-FP-X-06-S6	T43C04-FP-X-06-BR	3/8 - 18 NPTF
T43C04-FP-X-08-S6	T43C04-FP-X-08-BR	1/2 - 14 NPTF
T43C04-FP-X-12-S6	T43C04-FP-X-12-BR	3/4 - 14 NPTF

X = Seal Material - (E) EPDM, (B) BUNA-N, (V) FKM, (K) FFKM

Thorburn Series T43 Ring Lock Single Shut-Off Valve Couplings

Style T43C04-HS | Hose Stem - Valved Coupler - 1/4" Body



Thorburn Part #		Hose ID
316 Stainless Steel	Brass	in
T43C04-HS-X-04-S6	T43C04-HS-X-04-BR	1/4
T43C04-HS-X-06-S6	T43C04-HS-X-06-BR	3/8
T43C04-HS-X-08-S6	T43C04-HS-X-08-BR	1/2
T43C04-HS-X-12-S6	T43C04-HS-X-12-BR	3/4

X = Seal Material - (E) EPDM, (B) BUNA-N, (V) FKM, (K) FFKM

Note: Requires a clamp or ferrule to secure Thorburn Style T43C04-HS fittings to a hose (See Pages 98 to 110)

Style T43P04-MP | Male NPT - Non-Valved Plug - 1/4" Body



Thorburn Part #		Thread Size
316 Stainless Steel	Brass	in
T43P04-MP02-S6	T43P04-MP02-BR	1/8 - 27 NPTF
T43P04-MP04-S6	T43P04-MP04-BR	1/4 - 18 NPTF
T43P04-MP06-S6	T43P04-MP06-BR	3/8 - 18 NPTF
T43P04-MP08-S6	T43P04-MP08-BR	1/2 - 14 NPTF
T43P04-MP12-S6	T43P04-MP12-BR	3/4 - 14 NPTF

Style T43P04-FP | Female NPT - Non-Valved Plug - 1/4" Body



Thorburn Part #		Thread Size
316 Stainless Steel	Brass	in
T43P04-FP04-S6	T43P04-FP04-BR	1/4 - 18 NPTF
T43P04-FP06-S6	T43P04-FP06-BR	3/8 - 18 NPTF
T43P04-FP08-S6	T43P04-FP08-BR	1/2 - 14 NPTF
T43P04-FP12-S6	T43P04-FP12-BR	3/4 - 14 NPTF

Style T43P04-HS | Hose Stem - Non-Valved Plug - 1/4" Body



Thorburn Part #		Hose ID
316 Stainless Steel	Brass	in
T43P04-HS04-S6	T43P04-HS04-BR	1/4
T43P04-HS06-S6	T43P04-HS06-BR	3/8
T43P04-HS08-S6	T43P04-HS08-BR	1/2
T43P04-HS12-S6	T43P04-HS12-BR	3/4

Note: Requires a clamp or ferrule to secure Thorburn Style T43P04-HS fittings to a hose (See Pages 98 to 110)

Thorburn Series T43 Ring Lock Single Shut-Off Valve Couplings

Style T43C06-MP | Male NPT - Valved Coupler - 3/8" Body



Thorburn Part #		Thread Size
316 Stainless Steel	Brass	in
T43C06-MP-X-04-S6	T43C06-MP-X-04-BR	1/4 - 18 NPTF
T43C06-MP-X-06-S6	T43C06-MP-X-06-BR	3/8 - 18 NPTF
T43C06-MP-X-08-S6	T43C06-MP-X-08-BR	1/2 - 14 NPTF
T43C06-MP-X-12-S6	T43C06-MP-X-12-BR	3/4 - 14 NPTF

X = Seal Material - (E) EPDM, (B) BUNA-N, (V) FKM, (K) FFKM

Style T43C06-FP | Female NPT - Valved Coupler - 3/8" Body



Thorburn Part #		Thread Size
316 Stainless Steel	Brass	in
T43C06-FP-X-04-S6	T43C06-FP-X-04-BR	1/4 - 18 NPTF
T43C06-FP-X-06-S6	T43C06-FP-X-06-BR	3/8 - 18 NPTF
T43C06-FP-X-08-S6	T43C06-FP-X-08-BR	1/2 - 14 NPTF
T43C06-FP-X-12-S6	T43C06-FP-X-12-BR	3/4 - 14 NPTF

X = Seal Material - (E) EPDM, (B) BUNA-N, (V) FKM, (K) FFKM

Style T43C06-HS | Hose Stem - Valved Coupler - 3/8" Body



Thorburn Part #		Hose ID
316 Stainless Steel	Brass	in
T43C06-HS-X-04-S6	T43C06-HS-X-04-BR	1/4
T43C06-HS-X-06-S6	T43C06-HS-X-06-BR	3/8
T43C06-HS-X-08-S6	T43C06-HS-X-08-BR	1/2
T43C06-HS-X-12-S6	T43C06-HS-X-12-BR	3/4

X = Seal Material - (E) EPDM, (B) BUNA-N, (V) FKM, (K) FFKM

Note: Requires a clamp or ferrule to secure Thorburn Style T43C06-HS fittings to a hose (See Pages 98 to 110)

Style T43P06-MP | Male NPT - Non-Valved Plug - 3/8" Body



Thorburn Part #		Thread Size
316 Stainless Steel	Brass	in
T43P06-MP02-S6	T43P06-MP02-BR	1/8 - 27 NPTF
T43P06-MP04-S6	T43P06-MP04-BR	1/4 - 18 NPTF
T43P06-MP06-S6	T43P06-MP06-BR	3/8 - 18 NPTF
T43P06-MP08-S6	T43P06-MP08-BR	1/2 - 14 NPTF
T43P06-MP12-S6	T43P06-MP12-BR	3/4 - 14 NPTF

Thorburn Series T43 Ring Lock Single Shut-Off Valve Couplings

Style T43P06-FP | Female NPT - Non-Valved Plug - 3/8" Body



Thorburn Part #		Thread Size
316 Stainless Steel	Brass	in
T43P06-FP04-S6	T43P06-FP04-BR	1/4 - 18 NPTF
T43P06-FP06-S6	T43P06-FP06-BR	3/8 - 18 NPTF
T43P06-FP08-S6	T43P06-FP08-BR	1/2 - 14 NPTF
T43P06-FP12-S6	T43P06-FP12-BR	3/4 - 14 NPTF

Style T43P06-HS | Hose Stem - Non-Valved Plug - 3/8" Body



Thorburn Part #		Hose ID
316 Stainless Steel	Brass	in
T43P06-HS04-S6	T43P06-HS04-BR	1/4
T43P06-HS06-S6	T43P06-HS06-BR	3/8
T43P06-HS08-S6	T43P06-HS08-BR	1/2
T43P06-HS12-S6	T43P06-HS12-BR	3/4

Note: Requires a clamp or ferrule to secure Thorburn Style T43P06-HS fittings to a hose (See Pages 98 to 110)

Style T43DP | Dust Plug



Thorburn Part #	
1/4 inch body	3/8 inch body
T43DP04	T43DP06

Style T43DC | Dust Cap



Thorburn Part #	
1/4 inch body	3/8 inch body
T43DC04	T43DC06

Thorburn Air Hose 360° Swivels



Thorburn air hose swivels are designed for pneumatic applications, these fittings swivel 360° before and after installation as needed to prevent kinking between hose and portable air tools. Use live swivels for a continuous spin and faster hose winding and unwinding.

Thorburn Series TD22 In-Line Swivels: Low Pressure (10 bar)



Thorburn in-line swivel joints consist of an external barrel over a stem ideal for air and water applications. Swivel joints are not suitable for oil or hydraulic service.

- 360 degree swivel allows in-place connection in piping system
- Brass material for corrosion resistance, ductility at high temperatures, and low magnetic permeability
- 10 bar (150 psi) maximum working pressure at 21°C (70°F)
- Minimum 3:1 safety factor

Part #	NPTM	NPTF
	in	in
TD22-0404-BB	1/4	1/4
TD22-0606-BB	3/8	3/8

Thorburn Series (N)320T Parallel Swivels: Low Pressure (10 bar) 360° Swivel Joint



Thorburn parallel swivels are designed with 360° swivels at two locations which help to keep hose from kinking and protect the hose from twisting during operation. It has threaded holes in one male and one female pipe. The screw on the end of the unit adjusts the tension and prevents leaks.

- High-quality aluminum body for long-lasting durability
- Prevent hose kinking and increase tool maneuverability
- Swivels 360° in both directions
- Minimum 3:1 safety factor
- CRN available upon request

Part #	Inlet Thread	Outlet Thread
	in	in
(N)320T-0404-S6	1/4 NPT	1/4 NPT

Air Hose Manifolds

Thorburn's NPT 2 or 3 way manifolds are used to split an air hose into 2 or 3 separate hoses. The manifold features one NPT female input and three 1/4 inch NPT female outputs. Splitting the airline allows for operation of two or three tools from single supply hose, mount to pipe at a workbench or overhead that permits the use of air supply by more than one worker. Use with in-line regulators (not included) to achieve different PSI settings amongst multiple hoses.

- Designed to supply multiple air operated tools from a single supply hose
- Can be mounted to pipe at workbench or overhead
- Permits use of air supply by more than one mechanic.
- Strong, lightweight machined aluminum or brass construction
- 3:1 Safety Factor for all sizes



Operating Temperature: -40°C to 100°C (-40°F to 212°F)
Design Pressure: 20 bar (300 psi) for all sizes

Thorburn Series TD23 Two Connection Aluminum Manifold



Part #	NPT Inlet	NPT Outlet
	in	in
TD23-0404-AL	1/4 NPT	1/4 NPT
TD23-0604-AL	3/8 NPT	1/4 NPT
TD23-0804-AL	1/2 NPT	1/4 NPT

Thorburn Series TD34 Three Connection Aluminum Manifold



Part #	NPT Inlet	NPT Outlet
	in	in
TD34-0404-AL	1/4 NPT	1/4 NPT
TD34-0604-AL	3/8 NPT	1/4 NPT
TD34-0804-AL	1/2 NPT	1/4 NPT

Thorburn Series TD35 Three Connection Brass Flat Hex Manifold



Part #	NPT Inlet	NPT Outlet
	in	in
TD35-0404-BB	1/4 NPT	1/4 NPT
TD35-0604-BB	3/8 NPT	1/4 NPT
TD35-0804-BB	1/2 NPT	1/4 NPT

Thorburn Combination Hose Shank Couplings - Low Pressure



Thorburn combination hose shank couplings are designed for use on hose without enlargement of hose ends. Especially suitable for wire-woven hose to convey fuel or water fluids at low pressure by suction or discharge. Serrated shank attached to hose using positive sealing round wire clamps, single or double bolt clamps or flat bands. Not recommended for steam service. Not recommended for compressed air service for sizes 1 1/4" and above. **Other materials available upon request.**

Style 11IC | Male NPT



Note: Requires a clamp or ferrule to secure Thorburn Style 11IC fittings to a hose (See Pages 98 to 110)

Style 11IC			NPT End Materials				Hose ID		Thread
Plated Steel	316SS	Aluminum	Brass	Hasteloy	Nylon	Poly propylene	in	mm	in
11IC08-CP	11IC08-S6	11IC08-AL	11IC08-BB		-	11IC08-PP	1/2	12	3/4-14
11IC12-CP	11IC12-S6	11IC12-AL	11IC12-BB		-	11IC12-PP	3/4	20	3/4-14
11IC16-CP	11IC16-S6	11IC16-AL	11IC16-BB		-	11IC16-PP	1	25	1-11 1/2
11IC20-CP	11IC20-S6	11IC20-AL	11IC20-BB		11IC20-NN	-	1 1/4	32	1 1/4-11 1/2
11IC24-CP	11IC24-S6	11IC24-AL	11IC24-BB		11IC24-NN	11IC24-PP	1 1/2	38	1 1/2-11 1/2
11IC32-CP	11IC32-S6	11IC32-AL	11IC32-BB		11IC32-NN	11IC32-PP	2	50	2-11 1/2
11IC40-CP	11IC40-S6	11IC40-AL	11IC40-BB		-	-	2 1/2	64	2-8
11IC48-CP	11IC48-S6	11IC48-AL	11IC48-BB		11IC48-NN	11IC48-PP	3	76	3-8
11IC64-CP	11IC64-S6	11IC64-AL	11IC64-BB		-	-	4	102	4-8
11IC80-CP	11IC80-S6	11IC80-AL	11IC80-BB		-	-	5	127	5-8
11IC96-CP	11IC96-S6	11IC96-AL	11IC96-BB		-	-	6	152	6-8
11IC128-CP	11IC128-S6	11IC128-AL	-		-	-	8	203	8-8
11IC160-CP	11IC160-S6	-	-		-	-	10	254	10-8
11IC192-CP	11IC192-S6	-	-		-	-	12	305	12-8

Style 11IFS | Stub End for Floating Flanges



USAGE

To put a floating flange on at least one end of a hose assembly so that torsional stress is relieved in the hose and for ease in connecting to another flanged outlet.

Style 11IFS		Hose ID	
Plated Steel	316SS	in	mm
11IFS08-CP	11IFS08-S6	1/2	12
11IFS12-CP	11IFS12-S6	3/4	20
11IFS16-CP	11IFS16-S6	1	25
11IFS20-CP	11IFS20-S6	1 1/4	32
11IFS24-CP	11IFS24-S6	1 1/2	38
11IFS32-CP	11IFS32-S6	2	50
11IFS40-CP	11IFS40-S6	2 1/2	64
11IFS48-CP	11IFS48-S6	3	76
11IFS64-CP	11IFS64-S6	4	102
11IFS80-CP	11IFS80-S6	5	127
11IFS96-CP	11IFS96-S6	6	152
11IFS128-CP	11IFS128-S6	8	203
11IFS160-CP	11IFS160-S6	10	254
11IFS192-CP	11IFS192-S6	12	305

Note: Requires a clamp or ferrule to secure Thorburn Style 11IFS fittings to a hose (See Pages 95 to 107)

Thorburn Combination Hose Shank Couplings - Low Pressure

Style 11IV | Victaulic Grooved End



Note: Requires a clamp or ferrule to secure Thorburn Style 11IV fittings to a hose (See Pages 98 to 110)

Style 11IV		Hose ID	
Plated Steel	316SS	in	mm
11IV08-CP	11IV08-S6	1/2	13
11IV12-CP	11IV12-S6	3/4	19
11IV16-CP	11IV16-S6	1	25
11IV20-CP	11IV20-S6	1 1/4	32
11IV24-CP	11IV24-S6	1 1/2	38
11IV32-CP	11IV32-S6	2	51
11IV40-CP	11IV40-S6	2 1/2	64
11IV48-CP	11IV48-S6	3	76
11IV64-CP	11IV64-S6	4	102
11IV80-CP	11IV80-S6	5	127
11IV96-CP	11IV96-S6	6	152
11IV128-CP	11IV128-S6	8	203
11IV160-CP	11IV160-S6	10	254
11IV192-CP	11IV192-S6	12	305

Style 11IW | Welded End



Note: Requires a clamp or ferrule to secure Thorburn Style 11IW fittings to a hose (See Pages 98 to 110)

Style 11IW		Hose ID	
Carbon Steel	316SS	in	mm
11IW08-CS	11IW08-S6	1/2	13
11IW12-CS	11IW12-S6	3/4	19
11IW16-CS	11IW16-S6	1	25
11IW20-CS	11IW20-S6	1 1/4	32
11IW24-CS	11IW24-S6	1 1/2	38
11IW32-CS	11IW32-S6	2	51
11IW40-CS	11IW40-S6	2 1/2	64
11IW48-CS	11IW48-S6	3	76
11IW64-CS	11IW64-S6	4	102
11IW80-CS	11IW80-S6	5	127
11IW96-CS	11IW96-S6	6	152
11IW128-CS	11IW128-S6	8	203
11IW160-CS	11IW160-S6	10	254
11IW192-CS	11IW192-S6	12	305

Style 25I | Hose Mender



Note: Requires a clamp or ferrule to secure Thorburn Style 25I fittings to a hose (See Pages 98 to 110)

Style 25I			Hose ID	
Plated Steel	316SS	Nylon	in	mm
25I08-CP	25I08-S6	25I08-NN	1/2	13
25I12-CP	25I12-S6	25I12-NN	3/4	19
25I16-CP	25I16-S6	25I16-NN	1	25
25I20-CP	25I20-S6	25I20-NN	1 1/4	32
25I24-CP	25I24-S6	25I24-NN	1 1/2	38
25I32-CP	25I32-S6	25I32-NN	2	51
25I40-CP	25I40-S6	25I40-NN	2 1/2	64
25I48-CP	25I48-S6	25I48-NN	3	76
25I64-CP	25I64-S6	25I64-NN	4	102
25I80-CP	25I80-S6	25I80-NN	5	127
25I96-CP	25I96-S6	25I96-NN	6	152
25I128-CP	25I128-S6	25I128-NN	8	203
25I160-CP	25I160-S6	25I160-NN	10	254
25I192-CP	25I192-S6	25I192-NN	12	305

Shank Couplings For Water Discharge and Suction Services



Thorburn shank couplings are used for large diameter, low pressure, suction and discharge water hose. The couplings connect together with a threaded swivel nut and an rubber gasket that is included on the female side of the coupling. External clamps or crimped ferrules secure inside of the hose to the serrated shank. Thorburn male and female shank couplings are available in aluminium, brass and malleable iron. Pin lugs are used on all sizes of the female coupling half and 3 inches (76 mm) and above for the male coupling half making it easy to tighten by hand or with a spanner tool. The female pipe swivel has an NPSM (National Pipe Straight Mechanical) thread. The NPSM pipe swivel seats on a 30° seat and is visible down inside of the swivel nut. The swivel nut is permanently attached to the body and mates with the male pipe thread end that also has a 30° seat and together form a metal-to-metal seal. Thorburn shank couplings require a clamp or crimped ferrule to make a leak tight connection up to and including the burst pressure of the hose assembly.

Style 141 | Complete Set



Thorburn Part #			Hose ID		NPSM Thread Size
Aluminum Malleable Iron Swivel Nut	Brass	Plated Malleable Iron Swivel Nut	in	mm	in
14I16-AM	14I16-BB	14I16-MP	1	25	1 - 11 1/2
14I20-AM	14I20-BB	14I20-MP	1 1/4	32	1 1/4 - 11 1/2
14I24-AM	14I24-BB	14I24-MP	1 1/2	38	1 1/2 - 11 1/2
14I32-AM	14I32-BB	14I32-MP	2	51	2 - 11 1/2
14I40-AM	14I40-BB	14I40-MP	2 1/2	64	2 1/2 - 8
14I48-AM	14I48-BB	14I48-MP	3	76	3 - 8
14I64-AM	14I64-BB	14I64-MP	4	102	4 - 8
-	-	14I80-MP	5	127	5 - 8
14I96-AM	14I96-BB	14I96-MP	6	152	6 - 8

Note: Requires a clamp or ferrule to secure Thorburn Style 141 fittings to a hose (See Pages 98 to 110)

Shank Couplings For Water Discharge and Suction Services

Style 151 | Female Half



Thorburn Part #			Hose ID		NPSM Thread Size
Aluminum Malleable Iron Swivel Nut	Brass	Plated Malleable Iron Swivel Nut	in	mm	in
15116-AM	15116-BB	15116-MP	1	25	1 - 11 1/2
15120-AM	15120-BB	15120-MP	1 1/4	32	1 1/4 - 11 1/2
15124-AM	15124-BB	15124-MP	1 1/2	38	1 1/2 - 11 1/2
15132-AM	15132-BB	15132-MP	2	51	2 - 11 1/2
15140-AM	15140-BB	15140-MP	2 1/2	64	2 1/2 - 8
15148-AM	15148-BB	15148-MP	3	76	3 - 8
15164-AM	15164-BB	15164-MP	4	102	4 - 8
-	-	15180-MP	5	127	5 - 8
15196-AM	15196-BB	15196-MP	6	152	6 - 8

Note: Requires a clamp or ferrule to secure Thorburn Style 151 fittings to a hose (See Pages 98 to 110)

Style 161 | Male Half



Thorburn Part #			Hose ID		NPSM Thread Size
Aluminum Malleable Iron Swivel Nut	Brass	Plated Malleable Iron Swivel Nut	in	mm	in
16116-AM	16116-BB	16116-MP	1	25	1 - 11 1/2
16120-AM	16120-BB	16120-MP	1 1/4	32	1 1/4 - 11 1/2
16124-AM	16124-BB	16124-MP	1 1/2	38	1 1/2 - 11 1/2
16132-AM	16132-BB	16132-MP	2	51	2 - 11 1/2
16140-AM	16140-BB	16140-MP	2 1/2	64	2 1/2 - 8
16148-AM	16148-BB	16148-MP	3	76	3 - 8
16164-AM	16164-BB	16164-MP	4	102	4 - 8
-	-	16180-MP	5	127	5 - 8
16196-AM	16196-BB	16196-MP	6	152	6 - 8

Note: Requires a clamp or ferrule to secure Thorburn Style 161 fittings to a hose (See Pages 98 to 110)

Thorburn Camlock Quick Couplings



What is a Thorburn Camlock Quick Coupling?

A Thorburn camlock coupling, also called a cam and groove coupling, is used to connect two hoses and / or pipes together in a variety of industries, so that a commodity from one can be transferred to the other. They're easy to use, requiring no tools to connect and disconnect the two halves of the couplings and they replace the traditional time-consuming methods of some other types of hose or pipe connections. This, together with their cost effectiveness makes them the most popular coupling in the world.

Typically, Thorburn camlocks are used in every industry, such as manufacturing, agriculture, oil, gas, chemical, pharmaceutical and within military applications. They are an extremely versatile product, and because there are no threads when connecting the coupling halves together, there are no issues with them becoming damaged or dirty. Therefore, Thorburn camlock couplings are very suitable for dirty environments. The system is especially well suited to a situation where frequent changes of hoses are required, such as for petroleum, and industrial chemical trucks.

How does a Thorburn camlock quick coupling work?

The assembly consists of a male groove adapter and a female coupler. To connect and disconnect:

1. Extend the handles on the coupler outwards and place the correct size male adapter into the female coupler.
2. Close both handles at the same time until the two halves are firmly fixed together.
3. Closing both handles at the same time ensures that the grooved adapter is pulled down consistently onto the seal making a leak proof assembly for the safe transfer of liquids
4. Reverse the process to disconnect the fitting first making sure that the hose assembly has been de-pressurized.



Measuring ID of coupler



Measuring OD of adapter

How do I choose the right camlock coupling?

When specifying a fitting, there are seven fields of information required. The acronym for this is STAMPED, which stands for:

- S** = Size
- T** = Temperature
- A** = Application
- M** = Material (or media being used)
- P** = Pressure rating required
- E** = End fittings & connections (thread type)
- D** = Delivery (any extras, such as material certs)

How to measure the dimension of camlocks?

Measuring a metallic camlock fitting is reasonably easy. For instance, if the hose tail, male or female thread is 2", then the camlock coupling would be known as a 2" (DN50) camlock coupling.

Polypropylene is slightly different. There is no international standard and different manufacturers have different head sizes. For Thorburn's 1/2" size, the body is actually 3/4" but it's the thread (or hose tail) that is 1/2". There are also some anomalies in the 1 1/4" sized systems.

With Thorburn most cam couplings, measure the Outside Diameter (OD) of the adapter head or the Inside Diameter (ID) of the coupler. This will identify the fitting size, as depicted in the images below.

Thorburn Camlock Gaskets



Thorburn's Camlock Gaskets fit in the grooves of the female camlock or cam and groove couplings. The pressure of the fitting pushes against the gasket to create a tight seal. Our gaskets are designed to provide a touch seal and can be used safely within the food, petrochemical, and pharmaceutical industries. With an elastomer core and FEP/PFA exterior, the seals are perfect for chemical resistance. Thorburn's encapsulated gaskets have a non-stick finish, allowing for easier insertion and leak-free service. Thorburn Standard gasket material is Buna Nitrile, EPDM, PTFE, FKM and PTFE FKM.

Features

- All wetted parts PTFE
- Suitable for most brands of Camlocks
- Easy to replace
- Various materials available (refer to chemical resistance charts, Page 168)

Buna Nitrile Type Gaskets

Part Number	Size		Material (Standard)	Minimum Temperature		Maximum Temperature	
	in	mm		°F	°C	°F	°C
12TCFG-D	3/4	19	Nitrile Buna	-40	-40	93	34
16TCFG-D	1	25	Nitrile Buna	-40	-40	93	34
20TCFG-D	1 1/4	32	Nitrile Buna	-40	-40	93	34
24TCFG-D	1 1/2	38	Nitrile Buna	-40	-40	93	34
32TCFG-D	2	51	Nitrile Buna	-40	-40	93	34
40TCFG-D	2 1/2	64	Nitrile Buna	-40	-40	93	34
48TCFG-D	3	76	Nitrile Buna	-40	-40	93	34
64TCFG-D	4	102	Nitrile Buna	-40	-40	93	34
80TCFG-D	5	127	Nitrile Buna	-40	-40	93	34
96TCFG-D	6	152	Nitrile Buna	-40	-40	93	34

EPDM Type Gaskets

Part Number	Size		Material	Minimum Temperature		Maximum Temperature	
	in	mm		°F	°C	°F	°C
12TCFG-H	3/4	19	EPDM	-30	-34	149	65
16TCFG-H	1	25	EPDM	-30	-34	149	65
20TCFG-H	1 1/4	32	EPDM	-30	-34	149	65
24TCFG-H	1 1/2	38	EPDM	-30	-34	149	65
32TCFG-H	2	51	EPDM	-30	-34	149	65
40TCFG-H	2 1/2	64	EPDM	-30	-34	149	65
48TCFG-H	3	76	EPDM	-30	-34	149	65
64TCFG-H	4	102	EPDM	-30	-34	149	65
96TCFG-H	6	152	EPDM	-30	-34	149	65

PTFE Envelope Type Gaskets

Part Number	Size		Material	Minimum Temperature		Maximum Temperature	
	in	mm		°F	°C	°F	°C
12TCFG-JD	3/4	19	PTFE Env.	-40	-40	93	34
16TCFG-JD	1	25	PTFE Env.	-40	-40	93	34
20TCFG-JD	1 1/4	32	PTFE Env.	-40	-40	93	34
24TCFG-JD	1 1/2	38	PTFE Env.	-40	-40	93	34
32TCFG-JD	2	51	PTFE Env.	-40	-40	93	34
40TCFG-JD	2 1/2	64	PTFE Env.	-40	-40	93	34
48TCFG-JD	3	76	PTFE Env.	-40	-40	93	34
64TCFG-JD	4	102	PTFE Env.	-40	-40	93	34
96TCFG-JD	6	152	PTFE Env.	-40	-40	93	34

FKM Type Gaskets

Part Number	Size		Material	Minimum Temperature		Maximum Temperature	
	in	mm		°F	°C	°F	°C
12TCFG-I	3/4	19	FKM	-40	-40	200	93
16TCFG-I	1	25	FKM	-40	-40	200	93
20TCFG-I	1 1/4	32	FKM	-40	-40	200	93
24TCFG-I	1 1/2	38	FKM	-40	-40	200	93
32TCFG-I	2	51	FKM	-40	-40	200	93
40TCFG-I	2 1/2	64	FKM	-40	-40	200	93
48TCFG-I	3	76	FKM	-40	-40	200	93
64TCFG-I	4	102	FKM	-40	-40	200	93
96TCFG-I	6	152	FKM	-40	-40	200	93

PTFE-FKM Envelope Type Gaskets

Part Number	Size		Material	Minimum Temperature		Maximum Temperature	
	in	mm		°F	°C	°F	°C
12TCFG-JI	3/4	19	PTFE/FKM Env.	-40	-40	200	93
16TCFG-JI	1	25	PTFE/FKM Env.	-40	-40	200	93
20TCFG-JI	1 1/4	32	PTFE/FKM Env.	-40	-40	200	93
24TCFG-JI	1 1/2	38	PTFE/FKM Env.	-40	-40	200	93
32TCFG-JI	2	51	PTFE/FKM Env.	-40	-40	200	93
40TCFG-JI	2 1/2	64	PTFE/FKM Env.	-40	-40	200	93
48TCFG-JI	3	76	PTFE/FKM Env.	-40	-40	200	93
64TCFG-JI	4	102	PTFE/FKM Env.	-40	-40	200	93
96TCFG-JI	6	152	PTFE/FKM Env.	-40	-40	200	93

Thorburn Series 633 Camlock Couplings



To what standard are Thorburn camlocks manufactured?

Thorburn Series 633 camlock couplings are based on the US military specification Mil-C-27487 now superseded by A-A-59326D. The original specification was replaced by the new standard, but still guaranteed the interchangeability of couplings designed to the same specification. The Mil-C-27487 specified the casting methods, materials, dimensions, tolerances, pressure ratings, and inspection procedures.

Are Thorburn camlocks interchangeable?

Between manufacturers, cam and groove couplings are interchangeable with the exception of 1/2" (12.5mm), 5" and 8". The A-A-59326A Mil Specification does not apply to 5" and 8" cam and groove couplings due to the presence of two versions of cam and groove couplings in today's market.

European standard

The European standard EN 14420-7 was approved by CEN in September 2004 and was applied to cam and groove couplings manufactured to the American military standard, as outlined above. This American standard does not apply to the hose connection side, but only to the coupling side.

Thorburn camlock couplings produced to EN 14420-7 are interchangeable with those produced to the original MIL-C-27487 standard, but differ in terms of hose tail design, thread, and part number. A flat thread seal has been added to the female threaded parts and a smooth hose shank complying with EN 14420-7/DIN 2828 has been added for assembly with safety clamps complying with EN 14420-3/DIN 2817.

Cam Arms

All Thorburn cam arms are supplied complete with pins and finger rings. They are available in a sintered bronze forging, stainless steel, and an investment cast stainless steel. Bronze cams are standard on bronze, aluminum and iron. Sintered stainless cams are standard on polypropylene and nylon couplings. Our stainless steel couplings are equipped with 316 stainless steel cams. Any variation must be specified.

Metal	Size		Pressure	
	in	mm	PSI	bar
Aluminum, Brass Std. gasket 225°F Viton* 350°F but reduce pressure by 1/2 PTFE* gaskets also available	1/2	13	250	17
	3/4	19	250	17
	1	25	250	17
	1 1/4	32	250	17
	1 1/2	38	250	17
	2	51	250	17
	2 1/2	64	150	10
	3	76	125	9
	4	102	100	7
	5	127	75	5
	6	152	75	5
	8	203	50	3
Cast Iron Std. gasket 225°F Viton* gasket 350°F PTFE* gaskets also available	1/2	13	125	9
	3/4	19	125	9
	1	25	125	9
	1 1/2	38	125	9
	2	51	125	9
	2 1/2	64	100	7
	3	76	100	7
	4	102	100	7
Stainless Steel, Steel Std. gasket 225°F Viton** gasket 350°F PTFE** gasket 450°F	1/2	13	250	17
	3/4	19	250	17
	1	25	250	17
	1 1/4	32	250	17
	1 1/2	38	250	17
	2	51	150	10
	3	76	150	10
	4	102	150	10
Monel Std.w gasket 225°F Viton** gasket 350°F PTFE** gasket 450°F	1/2	13	250	17
	3/4	19	250	17
	1	25	250	17
	1 1/4	32	250	17
	1 1/2	38	250	17
	2	51	250	17
	2 1/2	64	200	14
	3	76	200	14
Polypropylene Std. gasket 70°F Std gasket 200°F Std gasket 70°F	1	25	100	7
	1 1/2 - 2	38 - 51	100	7
	1 1/2 - 2	38 - 51	50	3
	3	76	50	3

Pressures shown have a 3:1 safety factor

* For temperatures in excess of 225°F, consult Thorburn ** For temperatures in excess of 300°F, consult Thorburn. **Note:** For pressure requirements greater than above, consult Thorburn

Thorburn Series 633 Camlock Couplings

Style 633-C | Coupler Hose Shank



Note: Requires a clamp or ferrule to secure Thorburn Style 633-C fittings to a hose (See Pages 98 to 110)

Thorburn Camlock Part #							Hose ID	
Aluminum	Brass (BB)	Carbon Steel	316SS	Hd. ct. Aluminum	Poly-propylene	Nylon	in	mm
633-C08-AL	633-C08-BB	633-C08-CS	633-CS608-S6	633-C08-HA	633-C08-PP	633-C08-NN	1/2	12
633-C12-AL	633-C12-BB	633-C12-CS	633-CS612-S6	633-C12-HA	633-C12-PP	633-C12-NN	3/4	20
633-C16-AL	633-C16-BB	633-C16-CS	633-CS616-S6	633-C16-HA	633-C16-PP	633-C16-NN	1	25
633-C20-AL	633-C20-BB	633-C20-CS	633-CS620-S6	633-C20-HA	633-C20-PP	633-C20-NN	1 1/4	32
633-C24-AL	633-C24-BB	633-C24-CS	633-CS624-S6	633-C24-HA	633-C24-PP	633-C24-NN	1 1/2	38
633-C32-AL	633-C32-BB	633-C32-CS	633-CS632-S6	633-C32-HA	633-C32-PP	633-C32-NN	2	50
633-C40-AL	633-C40-BB	633-C40-CS	633-CS640-S6	633-C40-HA	-	-	2 1/2	64
633-C48-AL	633-C48-BB	633-C48-CS	633-CS648-S6	633-C48-HA	-	-	3	76
633-C64-AL	633-C64-BB	633-C64-CS	633-CS664-S6	633-C64-HA	-	-	4	102
633-C80-AL	633-C80-BB	-	633-CS680-S6	633-C80-HA	-	-	5	127
633-C96-AL	633-C96-BB	-	633-CS696-S6	633-C96-HA	-	-	6	152
633-C128-AL	633-C128-BB	-	633-CS6128-S6	633-C128-HA	-	-	8	203
633-C160-AL	-	-	633-CS6160-S6	633-C128-HA	-	-	10	254

Style 633-E | Adapter Hose Shank



Note: Requires a clamp or ferrule to secure Thorburn Style 633-E fittings to a hose (See Pages 98 to 110)

Thorburn Camlock Part #							Hose ID	
Aluminum	Brass (BB)	Carbon Steel	316SS	Hd. ct. Aluminum	Poly-propylene	Nylon	in	mm
633-E08-AL	633-E08-BB	633-E08-CS	633-E08-S6	633-E08-HA	633-E08-PP	633-E08-NN	1/2	12
633-E12-AL	633-E12-BB	633-E12-CS	633-E12-S6	633-E12-HA	633-E12-PP	633-E12-NN	3/4	20
633-E16-AL	633-E16-BB	633-E16-CS	633-E16-S6	633-E16-HA	633-E16-PP	633-E16-NN	1	25
633-E20-AL	633-E20-BB	633-E20-CS	633-E20-S6	633-E20-HA	633-E20-PP	633-E20-NN	1 1/4	32
633-E24-AL	633-E24-BB	633-E24-CS	633-E24-S6	633-E24-HA	633-E24-PP	633-E24-NN	1 1/2	38
633-E32-AL	633-E32-BB	633-E32-CS	633-E32-S6	633-E32-HA	633-E32-PP	633-E32-NN	2	50
633-E40-AL	633-E40-BB	633-E40-CS	633-E40-S6	633-E40-HA	-	-	2 1/2	64
633-E48-AL	633-E48-BB	633-E48-CS	633-E48-S6	633-E48-HA	-	-	3	76
633-E64-AL	633-E64-BB	633-E64-CS	633-E64-S6	633-E64-HA	-	-	4	102
633-E80-AL	633-E80-BB	-	633-E80-S6	633-E80-HA	-	-	5	127
633-E96-AL	633-E96-BB	-	633-E96-S6	633-E96-HA	-	-	6	152
633-E128-AL	633-E128-BB	-	633-E128-S6	633-E128-HA	-	-	8	203
633-E160-AL	-	-	633-E160-S6	633-E160-HA	-	-	10	254

Thorburn Series 633 Camlock Couplings

Style 633-B | Coupler Male NPT



Thorburn Camlock Part #							Hose ID	
Aluminum	Brass (BB)	Carbon Steel	316SS	Hd. ct. Aluminum	Poly-propylene	Nylon	in	mm
633-B08-AL	633-B08-BB	633-B08-CS	633-B08-S6	633-B08-HA	633-B08-PP	633-B08-NN	1/2	12
633-B12-AL	633-B12-BB	633-B12-CS	633-B12-S6	633-B12-HA	633-B12-PP	633-B12-NN	3/4	20
633-B16-AL	633-B16-BB	633-B16-CS	633-B16-S6	633-B16-HA	633-B16-PP	633-B16-NN	1	25
633-B20-AL	633-B20-BB	633-B20-CS	633-B20-S6	633-B20-HA	633-B20-PP	633-B20-NN	1 1/4	32
633-B24-AL	633-B24-BB	633-B24-CS	633-B24-S6	633-B24-HA	633-B24-PP	633-B24-NN	1 1/2	38
633-B32-AL	633-B32-BB	633-B32-CS	633-B32-S6	633-B32-HA	633-B32-PP	633-B32-NN	2	50
633-B40-AL	633-B40-BB	633-B40-CS	633-B40-S6	633-B40-HA	-	-	2 1/2	64
633-B48-AL	633-B48-BB	633-B48-CS	633-B48-S6	633-B48-HA	-	-	3	76
633-B64-AL	633-B64-BB	633-B64-CS	633-B64-S6	633-B64-HA	-	-	4	102
633-B80-AL	633-B80-BB	-	633-B80-S6	633-B80-HA	-	-	5	127
633-B96-AL	633-B96-BB	-	633-B96-S6	633-B96-HA	-	-	6	152
633-B128-AL	633-B128-BB	-	633-B128-S6	633-B128-HA	-	-	8	203
633-B160-AL	-	-	633-B160-S6	633-B160-HA	-	-	10	254

Style 633-D | Coupler Female NPT



Thorburn Camlock Part #							Hose ID	
Aluminum	Brass (BB)	Carbon Steel	316SS	Hd. ct. Aluminum	Poly-propylene	Nylon	in	mm
633-D08	633-D08-BB	633-D08-CS	633-D08-S6	633-D08-HA	633-D08-PP	633-D08-NN	1/2	12
633-D12	633-D12-BB	633-D12-CS	633-D12-S6	633-D12-HA	633-D12-PP	633-D12-NN	3/4	20
633-DAL16	633-D16-BB	633-D16-CS	633-D16-S6	633-D16-HA	633-D16-PP	633-D16-NN	1	25
633-DAL20	633-D20-BB	633-D20-CS	633-D20-S6	633-D20-HA	633-D20-PP	633-D20-NN	1 1/4	32
633-DAL24	633-D24-BB	633-D24-CS	633-D24-S6	633-D24-HA	633-D24-PP	633-D24-NN	1 1/2	38
633-DAL32	633-D32-BB	633-D32-CS	633-D32-S6	633-D32-HA	633-D32-PP	633-D32-NN	2	50
633-DAL40	633-D40-BB	633-D40-CS	633-D40-S6	633-D40-HA	-	-	2 1/2	64
633-DAL48	633-D48-BB	633-D48-CS	633-D48-S6	633-D48-HA	-	-	3	76
633-DAL64	633-D64-BB	633-D64-CS	633-D64-S6	633-D64-HA	-	-	4	102
633-DAL80	633-D80-BB	-	633-D80-S6	633-D80-HA	-	-	5	127
633-DAL96	633-D96-BB	-	633-D96-S6	633-D96-HA	-	-	6	152
633-DAL128	633-D128-BB	-	633-D128-S6	633-D128-HA	-	-	8	203
633-DAL160	-	-	633-D160-S6	633-D160-HA	-	-	10	254

Thorburn Series 633 Camlock Couplings

Style 633-A | Adapter Female NPT



Thorburn Camlock Part #							Hose ID	
Aluminum	Brass (BB)	Carbon Steel	316SS	Hd. ct. Aluminum	Poly-propylene	Nylon	in	mm
633-A08-AL	633-A08-BB	633-A08-CS	633-A08-S6	633-A08-HA	633-A08-PP	633-A08-NN	1/2	12
633-A12-AL	633-A12-BB	633-A12-CS	633-A12-S6	633-A12-HA	633-A12-PP	633-A12-NN	3/4	20
633-A16-AL	633-A16-BB	633-A16-CS	633-A16-S6	633-A16-HA	633-A16-PP	633-A16-NN	1	25
633-A20-AL	633-A20-BB	633-A20-CS	633-A20-S6	633-A20-HA	633-A20-PP	633-A20-NN	1 1/4	32
633-A24-AL	633-A24-BB	633-A24-CS	633-A24-S6	633-A24-HA	633-A24-PP	633-A24-NN	1 1/2	38
633-A32-AL	633-A32-BB	633-A32-CS	633-A32-S6	633-A32-HA	633-A32-PP	633-A32-NN	2	50
633-A40-AL	633-A40-BB	633-A40-CS	633-A40-S6	633-A40-HA	-	-	2 1/2	64
633-A48-AL	633-A48-BB	633-A48-CS	633-A48-S6	633-A48-HA	-	-	3	76
633-A64-AL	633-A64-BB	633-A64-CS	633-A64-S6	633-A64-HA	-	-	4	102
633-A80-AL	633-A80-BB	-	633-A80-S6	633-A80-HA	-	-	5	127
633-A96-AL	633-A96-BB	-	633-A96-S6	633-A96-HA	-	-	6	152
633-A128-AL	633-A128-BB	-	633-A128-S6	633-A128-HA	-	-	8	203
633-A160-AL	-	-	633-A160-S6	633-A160-HA	-	-	10	254

Style 633-F | Adapter Male NPT



Thorburn Camlock Part #							Hose ID	
Aluminum	Brass (BB) Bronze(BR)	Carbon Steel	316SS	Hd. ct. Aluminum	Poly-propylene	Nylon	in	mm
633-F08-AL	633-F08-BB	633-F08-CS	633-F08-S6	633-F08-HA	633-F08-PP	633-F08-NN	1/2	12
633-F12-AL	633-F12-BB	633-F12-CS	633-F12-S6	633-F12-HA	633-F12-PP	633-F12-NN	3/4	20
633-F16-AL	633-F16-BB	633-F16-CS	633-F16-S6	633-F16-HA	633-F16-PP	633-F16-NN	1	25
633-F20-AL	633-F20-BB	633-F20-CS	633-F20-S6	633-F20-HA	633-F20-PP	633-F20-NN	1 1/4	32
633-F24-AL	633-F24-BB	633-F24-CS	633-F24-S6	633-F24-HA	633-F24-PP	633-F24-NN	1 1/2	38
633-F32-AL	633-F32-BB	633-F32-CS	633-F32-S6	633-F32-HA	633-F32-PP	633-F32-NN	2	50
633-F40-AL	633-F40-BB	633-F40-CS	633-F40-S6	633-F40-HA	-	-	2 1/2	64
633-F48-AL	633-F48-BB	633-F48-CS	633-F48-S6	633-F48-HA	-	-	3	76
633-F64-AL	633-F64-BB	633-F64-CS	633-F64-S6	633-F64-HA	-	-	4	102
633-F80-AL	633-F80-BB	-	633-F80-S6	633-F80-HA	-	-	5	127
633-F96-AL	633-F96-BB	-	633-F96-S6	633-F96-HA	-	-	6	152
633-F128-AL	633-F128-BB	-	633-F128-S6	633-F128-HA	-	-	8	203
633-F160-AL	-	-	633-F128-S6	633-F160-HA	-	-	10	254

Thorburn Series 633 Camlock Couplings

Style 633-DC | Dust Cap



Thorburn Camlock Part #							Hose ID	
Aluminum	Brass (BB)	Carbon Steel	316SS	Hd. ct. Aluminum	Poly-propylene	Nylon	in	mm
633-DC08-AL	633-DC08-BB	633-DC08-CS	633-DC08-S6	633-DC08-HA	633-DC08-PP	633-DC08-NN	1/2	12
633-DC12-AL	633-DC12-BB	633-DC12-CS	633-DC12-S6	633-DC12-HA	633-DC12-PP	633-DC12-NN	3/4	20
633-DC16-AL	633-DC16-BB	633-DC16-CS	633-DC16-S6	633-DC16-HA	633-DC16-PP	633-DC16-NN	1	25
633-DC20-AL	633-DC20-BB	633-DC20-CS	633-DC20-S6	633-DC20-HA	633-DC20-PP	633-DC20-NN	1 1/4	32
633-DC24-AL	633-DC24-BB	633-DC24-CS	633-DC24-S6	633-DC24-HA	633-DC24-PP	633-DC24-NN	1 1/2	38
633-DC32-AL	633-DC32-BB	633-DC32-CS	633-DC32-S6	633-DC32-HA	633-DC32-PP	633-DC32-NN	2	50
633-DC40-AL	633-DC40-BB	633-DC40-CS	633-DC40-S6	633-DC40-HA	-	-	2 1/2	64
633-DC48-AL	633-DC48-BB	633-DC48-CS	633-DC48-S6	633-DC48-HA	-	-	3	76
633-DC64-AL	633-DC64-BB	633-DC64-CS	633-DC64-S6	633-DC64-HA	-	-	4	102
633-DC80-AL	633-DC80-BB	-	633-DC80-S6	633-DC80-HA	-	-	5	127
633-DC96-AL	633-DC96-BB	-	633-DC96-S6	633-DC96-HA	-	-	6	152
633-DC128-AL	633-DC128-BB	-	633-DC128-S6	633-DC128-HA	-	-	8	203
633-DC160-AL	-	-	633-DC160-S6	633-DC160-HA	-	-	10	254

Style 633-DP | Dust Plug



Thorburn Camlock Part #							Hose ID	
Aluminum	Brass (BB)	Carbon Steel	316SS	Hd. ct. Aluminum	Poly-propylene	Nylon	in	mm
633-DP08-AL	633-DP08-BB	633-DP08-CS	633-DP08-S6	633-DP08-HA	633-DP08-PP	633-DP08-NN	1/2	12
633-DP12-AL	633-DP12-BB	633-DP12-CS	633-DP12-S6	633-DP12-HA	633-DP12-PP	633-DP12-NN	3/4	20
633-DP16-AL	633-DP16-BB	633-DP16-CS	633-DP16-S6	633-DP16-HA	633-DP16-PP	633-DP16-NN	1	25
633-DP20-AL	633-DP20-BB	633-DP20-CS	633-DP20-S6	633-DP20-HA	633-DP20-PP	633-DP20-NN	1 1/4	32
633-DP24-AL	633-DP24-BB	633-DP24-CS	633-DP24-S6	633-DP24-HA	633-DP24-PP	633-DP24-NN	1 1/2	38
633-DP32-AL	633-DP32-BB	633-DP32-CS	633-DP32-S6	633-DP32-HA	633-DP32-PP	633-DP32-NN	2	50
633-DP40-AL	633-DP40-BB	633-DP40-CS	633-DP40-S6	633-DP40-HA	-	-	2 1/2	64
633-DP48-AL	633-DP48-BB	633-DP48-CS	633-DP48-S6	633-DP48-HA	-	-	3	76
633-DP64-AL	633-DP64-BB	633-DP64-CS	633-DP64-S6	633-DP64-HA	-	-	4	102
633-DP80-AL	633-DP80-BB	-	633-DP80-S6	633-DP80-HA	-	-	5	127
633-DP96-AL	633-DP96-BB	-	633-DP96-S6	633-DP96-HA	-	-	6	152
633-DP128-AL	633-DP128-BB	-	633-DP128-S6	633-DP128-HA	-	-	8	203
633-DP160-AL	-	-	633-DP160-S6	633-DP160-HA	-	-	10	254

Thorburn Series 633 Camlock Couplings

Style 633-PFC | Coupler Female Flange (Class 150)



Thorburn Camlock Part #							Hose ID	
Aluminum	Brass (BB)	Carbon Steel	316SS	Hd. ct. Aluminum	Poly-propylene	Nylon	in	mm
633-PFC08-AL	633-PFC08-BB	633-PFC08-CS	633-PFC08-S6	633-PFC08-HA	633-PFC08-PP	633-PFC08-NN	1/2	12
633-PFC12-AL	633-PFC12-BB	633-PFC12-CS	633-PFC12-S6	633-PFC12-HA	633-PFC12-PP	633-PFC12-NN	3/4	20
633-PFC16-AL	633-PFC16-BB	633-PFC16-CS	633-PFC16-S6	633-PFC16-HA	633-PFC16-PP	633-PFC16-NN	1	25
633-PFC20-AL	633-PFC20-BB	633-PFC20-CS	633-PFC20-S6	633-PFC20-HA	633-PFC20-PP	633-PFC20-NN	1 1/4	32
633-PFC24-AL	633-PFC24-BB	633-PFC24-CS	633-PFC24-S6	633-PFC24-HA	633-PFC24-PP	633-PFC24-NN	1 1/2	38
633-PFC32-AL	633-PFC32-BB	633-PFC32-CS	633-PFC32-S6	633-PFC32-HA	633-PFC32-PP	633-PFC32-NN	2	50
633-PFC40-AL	633-PFC40-BB	633-PFC40-CS	633-PFC40-S6	633-PFC40-HA	-	-	2 1/2	64
633-PFC48-AL	633-PFC48-BB	633-PFC48-CS	633-PFC48-S6	633-PFC48-HA	-	-	3	76
633-PFC64-AL	633-PFC64-BB	633-PFC64-CS	633-PFC64-S6	633-PFC64-HA	-	-	4	102
633-PFC80-AL	633-PFC80-BB	-	633-PFC80-S6	633-PFC80-HA	-	-	5	127
633-PFC96-AL	633-PFC96-BB	-	633-PFC96-S6	633-PFC96-HA	-	-	6	152
633-PFC128-AL	633-PFC128-BB	-	633-PFC128-S6	633-PFC128-HA	-	-	8	203
633-PFC160-AL	-	-	633-PFC160-S6	633-PFC160-HA	-	-	10	254

Style 633-PFE | Adapter Male Flange (Class 150)



Thorburn Camlock Part #							Hose ID	
Aluminum	Brass (BB)	Carbon Steel	316SS	Hd. ct. Aluminum	Poly-propylene	Nylon	in	mm
633-PFE08-AL	633-PFE08-BB	633-PFE08-CS	633-PFE08-S6	633-PFE08-HA	633-PFE08-PP	633-PFE08-NN	1/2	12
633-PFE12-AL	633-PFE12-BB	633-PFE12-CS	633-PFE12-S6	633-PFE12-HA	633-PFE12-PP	633-PFE12-NN	3/4	20
633-PFE16-AL	633-PFE16-BB	633-PFE16-CS	633-PFE16-S6	633-PFE16-HA	633-PFE16-PP	633-PFE16-NN	1	25
633-PFE20-AL	633-PFE20-BB	633-PFE20-CS	633-PFE20-S6	633-PFE20-HA	633-PFE20-PP	633-PFE20-NN	1 1/4	32
633-PFE24-AL	633-PFE24-BB	633-PFE24-CS	633-PFE24-S6	633-PFE24-HA	633-PFE24-PP	633-PFE24-NN	1 1/2	38
633-PFE32-AL	633-PFE32-BB	633-PFE32-CS	633-PFE32-S6	633-PFE32-HA	633-PFE32-PP	633-PFE32-NN	2	50
633-PFE40-AL	633-PFE40-BB	633-PFE40-CS	633-PFE40-S6	633-PFE40-HA	-	-	2 1/2	64
633-PFE48-AL	633-PFE48-BB	633-PFE48-CS	633-PFE48-S6	633-PFE48-HA	-	-	3	76
633-PFE64-AL	633-PFE64-BB	633-PFE64-CS	633-PFE64-S6	633-PFE64-HA	-	-	4	102
633-PFE80-AL	633-PFE80-BB	-	633-PFE80-S6	633-PFE80-HA	-	-	5	127
633-PFE96-AL	633-PFE96-BB	-	633-PFE96-S6	633-PFE96-HA	-	-	6	152
633-PFE128-AL	633-PFE128-BB	-	633-PFE128-S6	633-PFE128-HA	-	-	8	203
633-PFE160-AL	-	-	633-PFE160-S6	633-PFE160-HA	-	-	10	254

Thorburn Series 733 - 4 Lever High Pressure Camlock Couplings



Thorburn Series 733 camlock couplings are connected by opening the four coupler levers and inserting the male adapter into the coupler. Closing the four coupler levers by hand produces a uniform gasket compression without special tools. This feature provides for quick connection & disconnection of hose assemblies from pumps, tanks and other equipment. Thorburn Series 733 high pressure four lever camlock coupling system is designed for applications which require higher working pressures than Thorburn's 2 lever camlock coupling system. All Thorburn's couplings are supplied with Thorburn's Guard-Lok™ locking feature (standard). Conforms to DIN 2828 and A-A-59326 (MIL-C-27487) specifications to ensure interchangeability.

Thorburn's Guard-Lok™ Technology



Thorburn's Guard-Lok™ Technology

Prevents Accidental Opening During Operation

Thorburn's Camlock high pressure coupling series have a mechanism built into the levers which prevent accidental disconnection during operation. The coupling levers lock automatically into the coupler body, in the closed position and stay locked until opened manually. Ideal for applications where vibration is present, hose assemblies are dragged or the coupling could be accidentally opened resulting in disastrous spillage.

Guard-Lok™ Advantages

- Locks shut with one smooth motion
- Levers automatically lock to the body when closed
- Prevents accidental disconnection and loss of fluids during operation
- Effortless operation and simple to unlock
- Simple streamlined design does not require loose parts, clips or springs

Thorburn Series 733 - 4 Lever High Pressure Camlock Couplings

Design Specifications

Materials: Stainless Steel (SA351 CF8M/SA479 T316) - Carbon Steel and Brass (Available upon request)

Pressure: 1/2" ID to 1 1/4" ID - 400 psi (28 bar), 1 1/2" ID to 2 1/2" ID - 300 psi (21 bar), 3" ID - 275 psi (19 bar), 4" & 6" ID - 250 psi (17 bar) - 4:1 safety factor

Gasket: Buna-N (Standard). Also available in EPDM, FKM & PTFE Encapsulated Rubber (ER)

Temperature: Buna-N, EPDM 121°C (250°F), FKM, PTFE (ER) 99°C (210°F)

Warning: Thorburn's Camlock Couplings are designed for liquid transfer only (not to be used for air, gas or steam transfer systems)

733C-HD



Hose Shank to Female Coupler

733D-HD



Female NPT Coupler Adapter

633A-HD



Female NPT to Male Adapter

633FSW-HD



Socket Weld to Male Adapter

633FBW-HD



Butt Weld to Male Adapter

Thorburn Camlock Part #					Hose ID	
Female Hose Shank Coupler	Female Hose Shank Adapter	Female NPT Adapter	Adapter to Socket Weld	Adapter to Butt Weld	in	mm
733C-HD08-S6*	733D-HD08-S6	633A-HD08-S6	633FSW-HD08-S6	633FBW-HD08-S6	1/2	12
733C-HD12-S6*	733D-HD12-S6	633A-HD12-S6	633FSW-HD12-S6	633FBW-HD12-S6	3/4	20
733C-HD16-S6*	733D-HD16-S6	633A-HD16-S6	633FSW-HD16-S6	633FBW-HD16-S6	1	25
733C-HD20-S6*	733D-HD20-S6	633A-HD20-S6	6633FSW-HD20-S6	633FBW-HD20-S6	1 1/4	32
733C-HD24-S6*	733D-HD24-S6	633A-HD24-S6	633FSW-HD24-S6	633FBW-HD24-S6	1 1/2	38
733C-HD32-S6*	733D-HD32-S6	633A-HD32-S6	633FSW-HD32-S6	633FBW-HD32-S6	2	50
733C-HD40-S6*	733D-HD40-S6	633A-HD40-S6	633FSW-HD40-S6	633FBW-HD40-S6	2 1/2	64
733C-HD48-S6*	733D-HD48-S6	633A-HD48-S6	633FSW-HD48-S6	633FBW-HD48-S6	3	76
733C-HD64-S6*	733D-HD64-S6	633A-HD64-S6	633FSW-HD64-S6	633FBW-HD64-S6	4	102
733C-HD96-S6*	733D-HD96-S6	633A-HD96-S6	633FSW-HD96-S6	633FBW-HD96-S6	6	152

*Note: Requires a clamp or ferrule to secure Thorburn Style 733-HD fittings to a hose (See Pages 95 to 107)

Thorburn Series TB Bauer Type B Style Lever Couplings

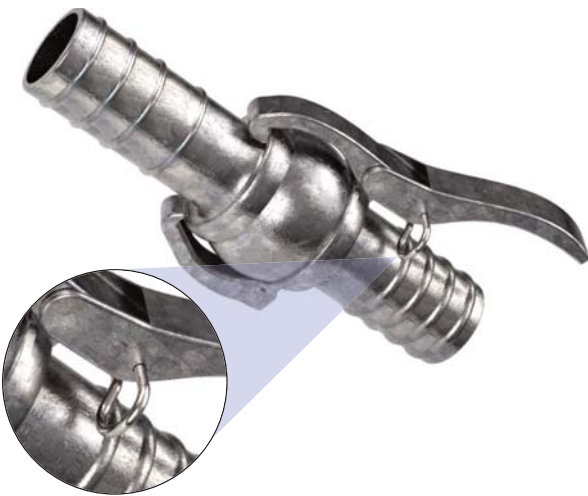

Thorburn Series TB - Male end with Closure Lever and Locking Pin

Thorburn Series TB lever couplings are an asymmetric coupling lever system where the male fitting has a double pin closure lever for smoother closing action. It is inserted into the female fitting and the joint closes by latching lever over the head of the female fitting. The couplings are designed to be bent in all directions by up to 30° and is still completely airtight and pressure-tight and can be coupled quickly and easily without special tools. Manufactured with high-strength quality steel with a hot-dip, abrasion-resistant, galvanizing process according to DIN EN ISO 1461. Pressure-tight up to 20 bar (300 PSI) for sizes up to 80mm, 10 bar (145 PSI) for sizes 100mm and above. Not interchangeable with Thorburn TP Series lever couplings.

Applications

- Mining, road and tunnel construction, exhaust gas systems
- Water, potable water and waste water, Sewage (loading/unloading)
- Agriculture (irrigation, sprinkling systems)
- Onshore and offshore drilling
- Food (grains, flour, seeds)
- Chemical Industry

Style TB309 | Male Hose Shank - Bauer Type B Compatible



Thorburn Part #	Nominal Hose ID		Material
	in	DN	
TB309-32-CP	2	50	Galvanized
TB309-48-CP	3	80	Galvanized
TB309-64-CP	4	100	Galvanized
TB309-96-CP	6	150	Galvanized
TB309-128-CP	8	200	Galvanized
TB309-192-CP	12	300	Galvanized

Note: Requires a clamp or ferrule to secure Thorburn Style TB309 fittings to a hose (See Pages 98 to 110)

Thorburn Series TB Bauer Type B Style Lever Couplings

Style TB310 | Female Hose Shank - Bauer Type B Compatible



Thorburn Part #	Nominal Hose ID		Material
	in	DN	
TB310-32-CP	2	50	Galvanized
TB310-48-CP	3	80	Galvanized
TB310-64-CP	4	100	Galvanized
TB310-96-CP	6	150	Galvanized
TB310-128-CP	8	200	Galvanized
TB310-192-CP	12	300	Galvanized

Note: Requires a clamp or ferrule to secure Thorburn Style TB310 fittings to a hose (See Pages 98 to 110)

Style TB311 | Male Socket with Male NPT - Bauer Type B Compatible



Thorburn Part #	Nominal Hose ID		NPT Thread Size	Material
	in	DN	in	
TB311-32-CP	2	50	2 - 11 1/2	Galvanized
TB311-48-CP	3	80	3 - 8	Galvanized
TB311-64-CP	4	100	4 - 8	Galvanized
TB311-96-CP	6	150	6 - 8	Galvanized
TB311-128-CP	8	200	8 - 8	Galvanized

Style TB312 | Female Plug with Male NPT - Bauer Type B Compatible



Thorburn Part #	Nominal Hose ID		NPT Thread Size	Material
	in	DN	in	
TB312-32-CP	2	50	2 - 11 1/2	Galvanized
TB312-48-CP	3	80	3 - 8	Galvanized
TB312-64-CP	4	100	4 - 8	Galvanized
TB312-96-CP	6	150	6 - 8	Galvanized
TB312-128-CP	8	200	8 - 8	Galvanized

Thorburn Series TB Bauer Type B Style Lever Couplings

Style TB313 | Male Socket with 150 ASA Flange - Bauer Type B Compatible



Thorburn Part #	Nominal Hose ID		Material
	in	DN	
TB313-64-CP	4	100	Galvanized
TB313-96-CP	6	150	Galvanized
TB313-128-CP	8	200	Galvanized
TB313-192-CP	12	300	Galvanized

Style TB314 | Female Socket with 150 ASA Flange - Bauer Type B Compatible



Thorburn Part #	Hose ID		Material
	in	mm	
TB314-64-CP	4	102	Galvanized
TB314-96-CP	6	152	Galvanized
TB314-128-CP	8	203	Galvanized
TB314-192-CP	12	305	Galvanized

Style TB308 | Female Plug with Gasket - Bauer Type B Compatible



Thorburn Part #	Hose ID		Material
	in	mm	
TB308-32-CP	2	50	Galvanized
TB308-48-CP	3	76	Galvanized
TB308-64-CP	4	102	Galvanized
TB308-96-CP	6	152	Galvanized
TB308-128-CP	8	203	Galvanized
TB308-192-CP	12	305	Galvanized

Thorburn Series TB Bauer Type B Style Lever Couplings

Style TB304 | Lever Ring - Bauer Type B Compatible



Thorburn Part #	Hose ID		Material
	in	mm	
TB304-32-CP	2	50	Galvanized
TB304-48-CP	3	76	Galvanized
TB304-64-CP	4	102	Galvanized
TB304-96-CP	6	152	Galvanized
TB304-128-CP	8	203	Galvanized
TB304-192-CP	12	305	Galvanized

Style TB306 | Gaskets - Bauer Type B Compatible



Thorburn Part #	Hose ID		Material
	in	mm	
TB306-32	2	50	EPDM
TB306-48	3	76	EPDM
TB306-64	4	102	EPDM
TB306-96	6	152	EPDM
TB306-128	8	203	EPDM
TB306-192	12	305	EPDM

Style TBLP | Locking Pins - Bauer Type B Compatible



Thorburn Part #	Hose ID		Material
	in	mm	
TBLP-32-CP	2	50	Galvanized
TBLP-48-CP	3	76	Galvanized
TBLP-64-CP	4	102	Galvanized
TBLP-96-CP	6	152	Galvanized
TBLP-128-CP	8	203	Galvanized
TBLP-192-CP	12	305	Galvanized

Thorburn Series TP Perrot Type C Style Lever Couplings

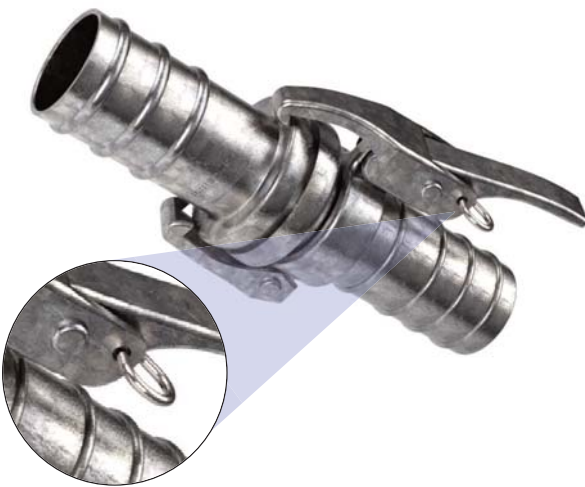

Thorburn Series TP - Female end with Closure Lever and Locking Pin

Thorburn Series TP Perrot type C style lever couplings consist of a male and a female part. The Female fitting incorporates a thick O-Ring seal and a closure lever with two claws. The male fitting is inserted into the female fitting and the joint is closed by latching the lever over the conical head of the male fitting. Pivoting of the levers is 15° on both sides. Couplings are made of galvanized steel with a working pressure of 10 bar (150 PSI), 8 bar (116 PSI) for sizes 200mm and 300mm, and a working temperature of -30°C (-22°F) to 80°C (176°F). Not interchangeable with Thorburn TB Series lever couplings.

Applications

- Agriculture, irrigation, sprinkling systems
- Ground water drainage, potable water, waste water
- Sewage loading, unloading
- On shore and off shore drilling
- Road and tunnel construction
- Environmental engineering
- Bulk Food (grains, flour, seeds)

Style TPKMS | Female Socket with Hose Stem - Perrot Type C Compatible



Note: Requires a clamp or ferrule to secure Thorburn Style TPKMS fittings to a hose (See Pages 98 to 110)

Thorburn Part #	Nominal Hose ID		Material
	in	DN	
TPKMS-32-CP	2	50	Galvanized
TPKMS-48-CP	3	80	Galvanized
TPKMS-64-CP	4	100	Galvanized
TPKMS-96-CP	6	150	Galvanized
TPKMS-128-CP	8	200	Galvanized
TPKMS-192-CP	12	300	Galvanized

Thorburn Series TP Perrot Type C Style Lever Couplings

Style TPKVS | Male Plug with Hose Stem - Perrot Type C Compatible



Thorburn Part #	Nominal Hose ID		Material
	in	DN	
TPKVS-32-CP	2	50	Galvanized
TPKVS-48-CP	3	80	Galvanized
TPKVS-64-CP	4	100	Galvanized
TPKVS-96-CP	6	150	Galvanized
TPKVS-128-CP	8	200	Galvanized
TPKVS-192-CP	12	300	Galvanized

Note: Requires a clamp or ferrule to secure Thorburn Style TPKVS fittings to a hose (See Pages 98 to 110)

Style TPKMG | Female Socket with Male NPT - Perrot Type C Compatible



Thorburn Part #	Nominal Hose ID		NPT Thread Size	Material
	in	DN	in	
TPKMG-32-CP	2	50	2 - 11 1/2	Galvanized
TPKMG-48-CP	3	80	3 - 8	Galvanized
TPKMG-64-CP	4	100	4 - 8	Galvanized
TPKMG-96-CP	6	150	6 - 8	Galvanized
TPKMG-128-CP	8	200	8 - 8	Galvanized
TPKMG-192-CP	12	300	12 - 8	Galvanized

Style TPKVG | Male Plug with Male NPT - Perrot Type C Compatible



Thorburn Part #	Nominal Hose ID		NPT Thread Size	Material
	in	DN	in	
TPKVG-32-CP	2	50	2 - 11 1/2	Galvanized
TPKVG-48-CP	3	80	3 - 8	Galvanized
TPKVG-64-CP	4	100	4 - 8	Galvanized
TPKVG-96-CP	6	150	6 - 8	Galvanized
TPKVG-128-CP	8	200	8 - 8	Galvanized
TPKVG-192-CP	12	300	12 - 8	Galvanized

Thorburn Series TP Perrot Type C Style Lever Couplings

Style TPKMF | Female Socket with 150 ASA Flange - Perrot Type C Compatible



Thorburn Part #	Nominal Hose ID		Material
	in	DN	
TPKMF-32-CP	2	50	Galvanized
TPKMF-48-CP	3	80	Galvanized
TPKMF-64-CP	4	100	Galvanized
TPKMF-96-CP	6	150	Galvanized
TPKMF-128-CP	8	200	Galvanized
TPKMF-192-CP	12	300	Galvanized

Style TPKVF | Male Plug with 150 ASA Flange - Perrot Type C Compatible



Thorburn Part #	Hose ID		Material
	in	mm	
TPKVF-32-CP	2	50	Galvanized
TPKVF-48-CP	3	76	Galvanized
TPKVF-64-CP	4	102	Galvanized
TPKVF-96-CP	6	152	Galvanized
TPKVF-128-CP	8	203	Galvanized
TPKVF-192-CP	12	305	Galvanized

Style TPKMR | Female End Cap - Perrot Type C Compatible



Thorburn Part #	Hose ID		Material
	in	mm	
TPKMR-32-CP	2	50	Galvanized
TPKMR-48-CP	3	76	Galvanized
TPKMR-64-CP	4	102	Galvanized
TPKMR-96-CP	6	152	Galvanized
TPKMR-128-CP	8	203	Galvanized
TPKMR-192-CP	12	305	Galvanized

Thorburn Series TP Perrot Type C Style Lever Couplings

Style TPKVX | Male End Cap - Perrot Type C Compatible



Thorburn Part #	Hose ID		Material
	in	mm	
TPKVX-32-CP	2	50	Galvanized
TPKVX-48-CP	3	76	Galvanized
TPKVX-64-CP	4	102	Galvanized
TPKVX-96-CP	6	152	Galvanized
TPKVX-128-CP	8	203	Galvanized
TPKVX-192-CP	12	305	Galvanized

Style TPKLR | Lever Ring - Perrot Type C Compatible



Thorburn Part #	Hose ID		Material
	in	mm	
TPKLR-32-CP	2	50	Galvanized
TPKLR-48-CP	3	76	Galvanized
TB304-64-CP	4	102	Galvanized
TPKLR-96-CP	6	152	Galvanized
TPKLR-128-CP	8	203	Galvanized
TPKLR-192-CP	12	305	Galvanized

Style TPG | Gaskets - Perrot Type C Compatible



Thorburn Part #	Hose ID		Material
	in	mm	
TPG-32	.2	50	EPDM
TPG-48	3	76	EPDM
TPG-64	4	102	EPDM
TPG-96	6	152	EPDM
TPG-128	8	203	EPDM
TPG-192	12	305	EPDM

Style TPLP | Locking Pins - Perrot Type C Compatible



Thorburn Part #	Hose ID		Material
	in	mm	
TPLP-32	2	50	Galvanized
TPLP-48	3	76	Galvanized
TPLP-64	4	102	Galvanized
TPLP-96	6	152	Galvanized
TPLP-128	8	203	Galvanized
TPLP-192	12	305	Galvanized

Thorburn Series 70 Hose Couplings for Bolt-On Safety Clamps



Thorburn Series 70 EN 14420-5 hose couplings are used to connect hoses with male or female BSP, BSPT or NPT threaded couplings. The coupling is designed to be used with Thorburn Style 70BSC Bolt-On Safety Clamp (EN14420-3/DIN 2817). Hose, coupling, assembly method and seal must be chosen in relation with the desired application and temperature range. Thorburn EN 14420-5 hose couplings are not interchangeable with Thorburn EN 14423 hose couplings, due to differences in application and overall dimensions.

Application

To connect rubber and thermoplastic hoses.

Working Pressure

25 bar (363 psi)

Temperature Range:

-30°C (-22°F) up to 300°C (572°F)

Material:

Coupling: SS316 or Brass

Seal Material:

316SS Coupling: PTFE

Brass Coupling: Polyurethane (PU)



Thorburn Series 70 EN 14420-5 Hose Couplings and EN14420-4 Flanges are designed for use with Thorburn Style 80BSC EN14420-3/DIN 2817 Bolt-On Safety Clamps (Pg 94)

Style 71FBSP | Female BSPP Fitting - Smooth Stem EN 14420-5/DIN 2817



Part Number		Nominal Hose I.D.		Thread
316SS	Brass	DN	in	Inch
71FBSP08-S6	71FBSP08-BB	15	1/2	1/2
71FBSP12-S6	71FBSP12-BB	20	3/4	3/4
71FBSP16-S6	71FBSP16-BB	25	1	1
71FBSP20-S6	71FBSP20-BB	32	1 1/4	1 1/4
71FBSP24-S6	71FBSP24-BB	40	1 1/2	1 1/2
71FBSP32-S6	71FBSP32-BB	50	2	2
71FBSP40-S6	71FBSP40-BB	65	2 1/2	2 1/2
71FBSP48-S6	71FBSP48-BB	80	3	3
71FBSP64-S6	71FBSP64-BB	100	4	4

To assemble the insert, use Thorburn Style 70BSC (EN 14420-3/DIN 2817) Bolt-On Safety Clamps

Thorburn Series 70 Hose Couplings for Bolt-On Safety Clamps

Style 72FBSPP | Female BSPP Fitting - Serrated Stem EN 14420-5/DIN 2817



Part Number		Nominal Hose I.D.		Thread
316SS	Brass	DN	in	Inch
72FBSPP08-S6	72FBSPP08-BB	15	1/2	1/2
72FBSPP12-S6	72FBSPP12-BB	20	3/4	3/4
72FBSPP16-S6	72FBSPP16-BB	25	1	1
72FBSPP20-S6	72FBSPP20-BB	32	1 1/4	1 1/4
72FBSPP24-S6	72FBSPP24-BB	40	1 1/2	1 1/2
72FBSPP32-S6	72FBSPP32-BB	50	2	2
72FBSPP40-S6	72FBSPP40-BB	65	2 1/2	2 1/2
72FBSPP48-S6	72FBSPP48-BB	80	3	3
72FBSPP64-S6	72FBSPP64-BB	100	4	4

To assemble the insert, use Thorburn Style 70BSC (EN 14420-3/DIN 2817) Bolt-On Safety Clamps

Style 73MBSPT | Male BSPT Fitting - Smooth Stem EN 14420-5/DIN 2817



Part Number		Nominal Hose I.D.		Thread
316SS	Brass	DN	in	Inch
73MBSPT08-S6	73MBSPT08-BB	15	1/2	1/2
73MBSPT12-S6	73MBSPT12-BB	20	3/4	3/4
73MBSPT16-S6	73MBSPT16-BB	25	1	1
73MBSPT20-S6	73MBSPT20-BB	32	1 1/4	1 1/4
73MBSPT24-S6	73MBSPT24-BB	40	1 1/2	1 1/2
73MBSPT32-S6	73MBSPT32-BB	50	2	2
73MBSPT40-S6	73MBSPT40-BB	65	2 1/2	2 1/2
73MBSPT48-S6	73MBSPT48-BB	80	3	3
73MBSPT64-S6	73MBSPT64-BB	100	4	4

To assemble the insert, use Thorburn Style 70BSC (EN 14420-3/DIN 2817) Bolt-On Safety Clamps

Style 74MBSPT | Male BSPT Fitting - Serrated Stem EN 14420-5/DIN 2817



Part Number		Nominal Hose I.D.		Thread
316SS	Brass	DN	in	Inch
74MBSPT08-S6	74MBSPT08-BB	15	1/2	1/2
74MBSPT12-S6	74MBSPT12-BB	20	3/4	3/4
74MBSPT16-S6	74MBSPT16-BB	25	1	1
74MBSPT20-S6	74MBSPT20-BB	32	1 1/4	1 1/4
74MBSPT24-S6	74MBSPT24-BB	40	1 1/2	1 1/2
74MBSPT32-S6	74MBSPT32-BB	50	2	2
74MBSPT40-S6	74MBSPT40-BB	65	2 1/2	2 1/2
74MBSPT48-S6	74MBSPT48-BB	80	3	3
74MBSPT64-S6	74MBSPT64-BB	100	4	4

To assemble the insert, use Thorburn Style 70BSC (EN 14420-3/DIN 2817) Bolt-On Safety Clamps

Thorburn Series 70 Hose Couplings for Bolt-On Safety Clamps

Style 75FLX | Fixed Flange - Smooth Stem EN 14420-4/DIN 2817



Part Number		Nominal Hose I.D.	
316SS	Brass	DN	in
75FLX16XX-S6	75FLX16XX-BB	25	1
75FLX20XX-S6	75FLX20XX-BB	32	1 1/4
75FLX24XX-S6	75FLX24XX-BB	40	1 1/2
75FLX32XX-S6	75FLX32XX-BB	50	2
75FLX40XX-S6	75FLX40XX-BB	65	2 1/2
75FLX48XX-S6	75FLX48XX-BB	80	3
75FLX64XX-S6	75FLX64XX-BB	100	4
75FLX16XX-S6	75FLX16XX-BB	125	5
75FLX96XX-S6	75FLX96XX-BB	150	6
75FLX128XX-S6	75FLX128XX-BB	200	8

XX = Specify Flange Type:

FL1 = CL150 ANSI, **FL2** = CL300 ANSI, **FL3** = PN10, **FL4** = PN16 **FL5** = PN25, **FL6** = PN40

To assemble the insert, use Thorburn Style 70BSC (EN 14420-3/DIN 2817) Bolt-On Safety Clamps

Style 76FLX | Fixed Flange - Serrated Stem EN 14420-4/DIN 2817



Part Number		Nominal Hose I.D.	
316SS	Brass	DN	in
76FLX16XX-S6	76FLX16XX-BB	25	1
76FLX20XX-S6	76FLX20XX-BB	32	1 1/4
76FLX24XX-S6	76FLX24XX-BB	40	1 1/2
76FLX32XX-S6	76FLX32XX-BB	50	2
76FLX40XX-S6	76FLX40XX-BB	65	2 1/2
76FLX48XX-S6	76FLX48XX-BB	80	3
76FLX64XX-S6	76FLX64XX-BB	100	4
76FLX16XX-S6	76FLX16XX-BB	125	5
76FLX96XX-S6	76FLX96XX-BB	150	6
76FLX128XX-S6	76FLX128XX-BB	200	8

XX = Specify Flange Type:

FL1 = CL150 ANSI, **FL2** = CL300 ANSI, **FL3** = PN10, **FL4** = PN16 **FL5** = PN25, **FL6** = PN40

To assemble the insert, use Thorburn Style 70BSC (EN 14420-3/DIN 2817) Bolt-On Safety Clamps

Thorburn Series 70 Hose Couplings for Bolt-On Safety Clamps

Style 77FLXS | Swivel Flange - Smooth Stem EN 14420-4/DIN 2817



Part Number		Nominal Hose I.D.	
316SS	Brass	DN	in
77FLXS16XX-S6	77FLXS16XX-BB	25	1
77FLXS20XX-S6	77FLXS20XX-BB	32	1 1/4
77FLXS24XX-S6	77FLXS24XX-BB	40	1 1/2
77FLXS32XX-S6	77FLXS32XX-BB	50	2
77FLXS40XX-S6	77FLXS40XX-BB	65	2 1/2
77FLXS48XX-S6	77FLXS48XX-BB	80	3
77FLXS64XX-S6	77FLXS64XX-BB	100	4
77FLXS16XX-S6	77FLXS16XX-BB	125	5
77FLXS96XX-S6	77FLXS96XX-BB	150	6
77FLXS128XX-S6	77FLXS128XX-BB	200	8

XX = Specify Flange Type:

FL1 = CL150 ANSI, **FL2** = CL300 ANSI, **FL3** = PN10, **FL4** = PN16 **FL5** = PN25, **FL6** = PN40

To assemble the insert, use Thorburn Style 70BSC (EN 14420-3/DIN 2817) Bolt-On Safety Clamps

Style 78FLXS | Swivel Flange - Serrated Stem EN 14420-4/DIN 2817



Part Number		Nominal Hose I.D.	
316SS	Brass	DN	in
78FLXS16XX-S6	78FLXS16XX-BB	25	1
78FLXS20XX-S6	78FLXS20XX-BB	32	1 1/4
78FLXS24XX-S6	78FLXS24XX-BB	40	1 1/2
78FLXS32XX-S6	78FLXS32XX-BB	50	2
78FLXS40XX-S6	78FLXS40XX-BB	65	2 1/2
78FLXS48XX-S6	78FLXS48XX-BB	80	3
78FLXS64XX-S6	78FLXS64XX-BB	100	4
78FLXS16XX-S6	78FLXS16XX-BB	125	5
78FLXS96XX-S6	78FLXS96XX-BB	150	6
78FLXS128XX-S6	78FLXS128XX-BB	200	8

XX = Specify Flange Type:

FL1 = CL150 ANSI, **FL2** = CL300 ANSI, **FL3** = PN10, **FL4** = PN16 **FL5** = PN25, **FL6** = PN40

To assemble the insert, use Thorburn Style 70BSC (EN 14420-3/DIN 2817) Bolt-On Safety Clamps

Thorburn Series 80 Hose Couplings for Bolt-On Safety Clamps



Thorburn EN 14423 hose couplings are used to connect hoses with male or female BSP, BSPT or NPT threaded couplings. The coupling is designed to be used with Thorburn Style 80BSC Bolt-On Safety Clamp (EN14423 / DIN 2826) For steam service applications. The Hose, coupling, assembly method and seal must be chosen in relation with the desired application and temperature range. Thorburn EN 14423 hose couplings are not interchangeable with Thorburn EN 14420 couplings, due to differences in application and overall dimensions.

Application

To connect rubber and thermoplastic hoses.

Working Pressure

25 bar (363 psi)

Temperature Range:

-30°C (-22°F) up to 300°C (572°F)

Material:

Coupling: SS316 or Brass

Seal Material:

Brass Coupling: PU
316SS Coupling: PTFE



Thorburn Series 80 EN 14423 Hose Couplings are designed for use with Thorburn Style 80BSC EN14423/DIN 2826 Bolt-On Safety Clamps (Pg 95)

Style 81FBSP | Female BSPP Fitting - EN 14423/DIN 2826



Part Number		Nominal Hose I.D.		Thread
316SS	Brass	DN	in	Inch
81FBSP08-S6	81FBSP08-BB	15	1/2	1/2
81FBSP12-S6	81FBSP12-BB	20	3/4	3/4
81FBSP16-S6	81FBSP16-BB	25	1	1
81FBSP20-S6	81FBSP20-BB	32	1 1/4	1 1/4
81FBSP24-S6	81FBSP24-BB	40	1 1/2	1 1/2
81FBSP32-S6	81FBSP32-BB	50	2	2

To assemble the insert, use Thorburn Style 80BSC (EN 14423/DIN 2826) Bolt-On Safety Clamps

Thorburn Series 80 Hose Couplings for Bolt-On Safety Clamps

Style 82MBSPT | Male BSPT Fitting - EN 14423/DIN 2826



Part Number		Nominal Hose I.D.		Thread
316SS	Brass	DN	in	Inch
82FBSPP08-S6	82FBSPP08-BB	15	1/2	1/2
82FBSPP12-S6	82FBSPP12-BB	20	3/4	3/4
82FBSPP16-S6	82FBSPP16-BB	25	1	1
82FBSPP20-S6	82FBSPP20-BB	32	1 1/4	1 1/4
82FBSPP24-S6	82FBSPP24-BB	40	1 1/2	1 1/2
82FBSPP32-S6	82FBSPP32-BB	50	2	2

To assemble the insert, use Thorburn Style 80BSC (EN 14423/DIN 2826) Bolt-On Safety Clamps

Style 83FLX | Fixed Flange - EN 14423/DIN 2826



Part Number		Nominal Hose I.D.	
316SS	Brass	DN	in
83FLXS08XX-S6	83FLXS08XX-BB	15	1/2
83FLXS12XX-S6	83FLXS12XX-BB	20	3/4
83FLXS16XX-S6	83FLXS16XX-BB	25	1
83FLXS20XX-S6	83FLXS20XX-BB	32	1 1/4
83FLXS24XX-S6	83FLXS24XX-BB	40	1 1/2
83FLXS32XX-S6	83FLXS32XX-BB	50	2

XX = Specify Flange Type:

FL1 = CL150 ANSI, FL2 = CL300 ANSI, FL3 = PN10, FL4 = PN16 FL5 = PN25, FL6 = PN40

To assemble the insert, use Thorburn Style 80BSC (EN 14423/DIN 2826) Bolt-On Safety Clamps

Style 84FLXS | Swivel Flange - EN 14423/DIN 2826



Part Number		Nominal Hose I.D.	
316SS	Brass	DN	in
84FLXS08XX-S6	84FLXS08XX-BB	15	1/2
84FLXS12XX-S6	84FLXS12XX-BB	20	3/4
84FLXS16XX-S6	84FLXS16XX-BB	25	1
84FLXS20XX-S6	84FLXS20XX-BB	32	1 1/4
84FLXS24XX-S6	84FLXS24XX-BB	40	1 1/2
84FLXS32XX-S6	84FLXS32XX-BB	50	2

XX = Specify Flange Type:

FL1 = CL150 ANSI, FL2 = CL300 ANSI, FL3 = PN10, FL4 = PN16 FL5 = PN25, FL6 = PN40

To assemble the insert, use Thorburn Style 80BSC (EN 14423/DIN 2826) Bolt-On Safety Clamps

Thorburn Heavy Duty Ground Joint Couplings

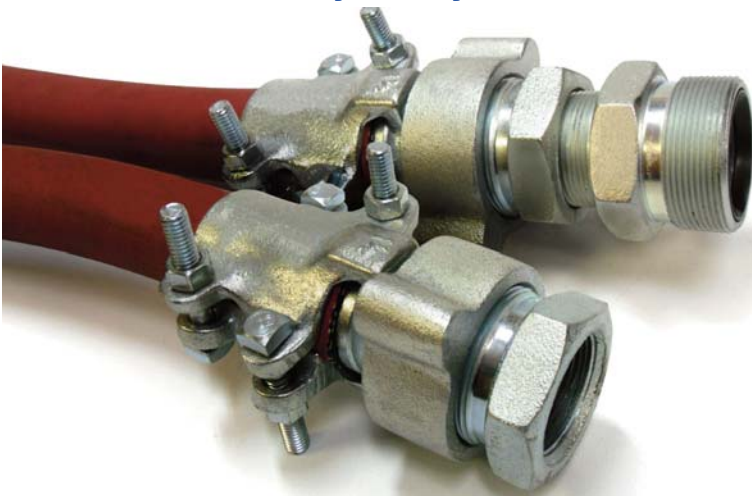

Thorburn's Ground Joint Coupling System are all-purpose hose couplings, universally recommended for steam hose connections, they are also widely used for air, water, fluid petroleum, chemicals and liquid petroleum gas. They provide compatible threads for connecting two lengths of steam hose or for connecting a length of hose to equipment. These barbed hose fittings grip the inside of the hose to hold the fitting in place and are secured with an interlocking clamp to create a leak-resistant seal. The coarse threads make ground joint fittings easy to couple in the field, and the heavy wing nuts can be tightened using a hammer or mallet. Must be used with Thorburn high pressure interlocking clamps found on page 104.

Applications

- Steam service
- Air supply for construction, road building, and drilling applications.
- Humidification
- Washdown service

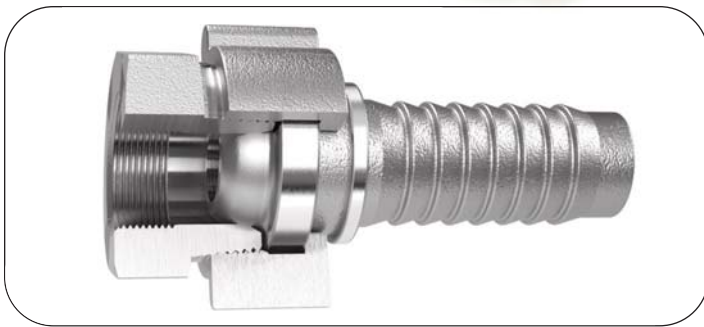

Style 171 | Hose Stem with Wing Nut & Female Spud



Thorburn Part #			Hose ID	
Malleable Iron	Brass	316SS	in	mm
17104-MI	-	-	1/4	6
17106-MI	-	-	3/8	10
17108-MI	-	-	1/2	13
17112-MI	171B12-BB	171S612-S6	3/4	19
17116-MI	171B16-BB	171S616-S6	1	25
17120-MI	171B20-BB	171S620-S6	1 1/4	32
17124-MI	171B24-BB	171S624-S6	1 1/2	38
17132-MI	171B32-BB	171S632-S6	2	51
17140-MI	-	-	2 1/2	64
17148-MI	-	-	3	76
17164-MI	-	-	4	102
17180-MI	-	-	5	127
17196-MI	-	-	6	152

Available in other sizes upon request. Minimum quantities apply.

Note: Includes Styles 181, 191 & 201. Requires a clamp or ferrule to secure Thorburn Style 171 fittings to a hose (See Pages 98 to 110)

Thorburn Heavy Duty Ground Joint Couplings

Style 25I | Hose Stem with Wing Nut & Male Spud



Note: Includes Styles 181, 191 & 211. Requires a clamp or ferrule to secure Thorburn Style 25I fittings to a hose (See Pages 98 to 110)

Thorburn Part #			Hose ID	
Malleable Iron	Brass	316SS	in	mm
25I04-MI	-	-	1/4	6
25I06-MI	-	-	3/8	10
25I08-MI	-	-	1/2	13
25I12-MI	25I12-BB	25I12-S6	3/4	19
25I16-MI	25I16-BB	25I16-S6	1	25
25I20-MI	25I20-BB	25I20-S6	1 1/4	32
25I24-MI	25I24-BB	25I24-S6	1 1/2	38
25I32-MI	25I32-BB	25I32-S6	2	51
25I40-MI	-	-	2 1/2	64
25I48-MI	-	-	3	76
25I64-MI	-	-	4	102
25I80-MI	-	-	5	127
25I96-MI	-	-	6	152

Available in other sizes upon request. Minimum quantities apply.

Style 18I | Hose Stem



Note: Requires a clamp or ferrule to secure Thorburn Style 18I fittings to a hose (See Pages 98 to 110)

Thorburn Part #			Hose ID	
Malleable Iron	Brass	316SS	in	mm
18I04-MI	-	-	1/4	6
18I06-MI	-	-	3/8	10
18I08-MI	-	-	1/2	13
18I12-MI	18I12-BB	18I12-S6	3/4	19
18I16-MI	18I16-BB	18I16-S6	1	25
18I20-MI	18I20-BB	18I20-S6	1 1/4	32
18I24-MI	18I24-BB	18I24-S6	1 1/2	38
18I32-MI	18I32-BB	18I32-S6	2	51
18I40-MI	-	-	2 1/2	64
18I48-MI	-	-	3	76
18I64-MI	-	-	4	102
18I80-MI	-	-	5	127
18I96-MI	-	-	6	152

Available in other sizes upon request. Minimum quantities apply.

Heavy Duty Ground Joint Couplings

Style 19I | Wing Nut



Thorburn Part #			Hose ID	
Malleable Iron	Brass	316SS	in	mm
19I04-MI	-	-	1/4	6
19I06-MI	-	-	3/8	10
19I08-MI	-	-	1/2	13
19I12-MI	19I12-BB	19I12-S6	3/4	19
19I16-MI	19I16-BB	19I16-S6	1	25
19I20-MI	19I20-BB	19I20-S6	1 1/4	32
19I24-MI	19I24-BB	19I24-S6	1 1/2	38
19I32-MI	19I32-BB	19I32-S6	2	51
19I40-MI	-	-	2 1/2	64
19I48-MI	-	-	3	76
19I64-MI	-	-	4	102
19I80-MI	-	-	5	127
19I96-MI	-	-	6	152

Available in other sizes upon request. Minimum quantities apply.

Style 20I | Male Spud - Female NPT



Thorburn Part #			Hose ID	
Malleable Iron	Brass	316SS	in	mm
20I04-MI	-	-	1/4	6
20I06-MI	-	-	3/8	10
20I08-MI	-	-	1/2	13
20I12-MI	20I12-BB	20I12-S6	3/4	19
20I16-MI	20I16-BB	20I16-S6	1	25
20I20-MI	20I20-BB	20I20-S6	1 1/4	32
20I24-MI	20I24-BB	20I24-S6	1 1/2	38
20I32-MI	20I32-BB	20I32-S6	2	51
20I40-MI	-	-	2 1/2	64
20I48-MI	-	-	3	76
20I64-MI	-	-	4	102
20I80-MI	-	-	5	127
20I96-MI	-	-	6	152

Available in other sizes upon request. Minimum quantities apply.

Style 21I | Male Spud - Male NPT



Thorburn Part #			Hose ID	
Malleable Iron	Brass	316SSI	in	mm
21I04-MI	-	-	1/4	6
21I06-MI	-	-	3/8	10
21I08-MI	-	-	1/2	13
21I12-MI	-	-	3/4	19
21I16-MI	-	-	1	25
21I20-MI	-	-	1 1/4	32
21I24-MI	-	-	1 1/2	38
21I32-MI	-	-	2	51
21I40-MI	-	-	2 1/2	64
21I48-MI	-	-	3	76

Available in other sizes upon request. Minimum quantities apply.

Heavy Duty Ground Joint Couplings

Style 221 | Double Male Spud



Thorburn Part #			Hose ID	
Malleable Iron	Brass	316SSI	in	mm
22108-MI	-	-	1/2	13
22112-MI	22112-BB	22112-S6	3/4	19
22116-MI	22116-BB	22116-S6	1	25
22120-MI	22120-BB	22120-S6	1 1/4	32
22124-MI	22124-BB	22124-S6	1 1/2	38
22132-MI	22132-BB	22132-S6	2	51
22140-MI	-	-	2 1/2	64
22148-MI	-	-	3	76

Available in other sizes upon request. Minimum quantities apply.

Style 231 | Male NPT Stem



Thorburn Part #				Hose ID	
Malleable Iron	Brass	316SS	Plated Steel	in	mm
23104-MI	23104-BB	23104-S6	23104-CP	1/4	06
23106-MI	23106-BB	23106-S6	23106-CP	3/8	10
23108-MI	23108-BB	23108-S6	23108-CP	1/2	13
23112-MI	23112-BB	23112-S6	23112-CP	3/4	19
23116-MI	23116-BB	23116-S6	23116-CP	1	25
23120-MI	23120-BB	23120-S6	23120-CP	1 1/4	32
23124-MI	23124-BB	23124-S6	23124-CP	1 1/2	38
23132-MI	23132-BB	23132-S6	23132-CP	2	51
23140-MI	23140-BB	23140-S6	23140-CP	2 1/2	64
23148-MI	23148-BB	23148-S6	23148-CP	3	76
23164-MI	23164-BB	23164-S6	23164-CP	4	102
23180-MI	23180-BB	23180-S6	23180-CP	5	127
23196-MI	23196-BB	23196-S6	23196-CP	6	152

Note: Requires a clamp or ferrule to secure Thorburn Style 231 fittings to a hose (See Pages 98 to 110)

Available in other sizes upon request. Minimum quantities apply.

Style 241 | Hose Splice



Thorburn Part #				Hose ID	
Malleable Iron	Brass	316SS	Plated Steel	in	mm
24104-MI	24104-BB	24104-S6	24104-CP	1/4	06
24106-MI	24106-BB	24106-S6	24106-CP	3/8	10
24108-MI	24108-BB	24108-S6	24108-CP	1/2	13
24112-MI	24112-BB	24112-S6	24112-CP	3/4	19
24116-MI	24116-BB	24116-S6	24116-CP	1	25
24120-MI	24120-BB	24120-S6	24120-CP	1 1/4	32
24124-MI	24124-BB	24124-S6	24124-CP	1 1/2	38
24132-MI	24132-BB	24132-S6	24132-CP	2	51
24140-MI	24140-BB	24140-S6	24140-CP	2 1/2	64
24148-MI	24148-BB	24148-S6	24148-CP	3	76
24164-MI	24164-BB	24164-S6	24164-CP	4	102
24180-MI	24180-BB	24180-S6	24180-CP	5	127
24196-MI	24196-BB	24196-S6	24196-CP	6	152

Note: Requires a clamp or ferrule to secure Thorburn Style 241 fittings to a hose (See Pages 98 to 110)

Available in other sizes upon request. Minimum quantities apply.

How To Order Thorburn Industrial Hose Assemblies

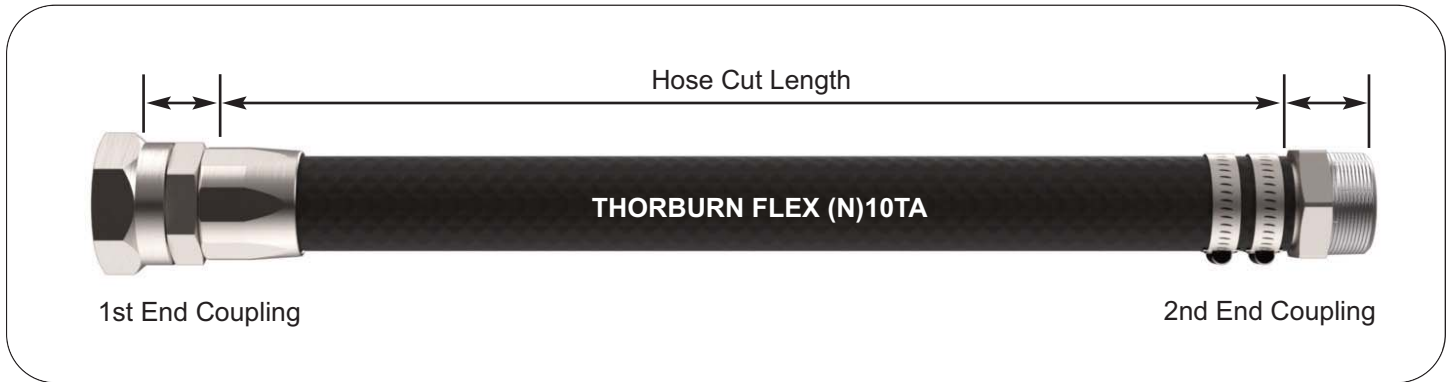

Model	Size	1st End Coupling	1st End Clamp or Crimp	2nd End Coupling	2nd End Clamp or Crimp	1st End Material	2nd End Material	Hose Length (in)	Option
(N)10TA	12	005	U	001	A2	S6	S6	96	TWSR
Air Hoses (N)10TA Pg 08 (N)11TANC Pg 09 (N)14TA Pg 10 (N)15TA Pg 11 (N)16TA Pg 11 (N)22TA Pg 12 (N)110TA Pg 13 (N)17TA Pg 14 (N)20TA Pg 15 (N)21TA Pg 15 (N)18TA Pg 16 Water Hose (N)21TW Pg 18 (N)24TW Pg 19 (N)224TW Pg 19 (N)26TW Pg 20 (N)26TWN Pg 20 (N)27TW Pg 21 (N)27TWN Pg 21 (N)118TW Pg 22 (N)220TW Pg 23 (N)221TW Pg 23 (N)25TWHHD Pg 24 (N)255TWHHD Pg 25 (N)256TWHHD Pg 25 Steam Hose (N)30TS Pg 27 (N)32TS Pg 27 (N)33TS Pg 27	Hose Size 01 = 1/16" 02 = 1/8" 03 = 3/16" 04 = 1/4" 05 = 5/16" 06 = 3/8" 07 = 7/16" 08 = 1/2" 10 = 5/8" 12 = 3/4" 14 = 7/8" 16 = 1" 20 = 1 1/4" 24 = 1 1/2" 32 = 2" 40 = 2 1/2" 48 = 3" 64 = 4" 80 = 5" 96 = 6" 128 = 8" 160 = 10" 192 = 12"	Couplings Please see Couplings list on page 93 Clamps A = 60CHS - Worm Gear Clamp Pg 98 B = 61CHAS - Worm Gear Clamp Pg 98 C = 62CC - Two Ear Clamp Pg 99 D = 65C Preformed Fast Lock* Pg 100 E = 69C - Single Bolt Clamp Pg 102 F = 70C - Double Bolt Clamp Pg 102 G = 71C - Stainless Bolt Clamp Pg 103 H = 72C - SS Tension Clamp Pg 103 I = 770CX - Spiral Clamp (CW) Pg 104 J = 771CX - Spiral Clamp (CCW) Pg 104 K = 777C - Perma-Clamp Pg 105 L = 778C - Hose Clamp Pg 106 M = 779C - Bag Clamp Pg 106 N = Style 71- 2 Bolt Clamp* Pg 107 O = Style 72- 4 Bolt Clamp* Pg 107 P = Style 73- 6 Bolt Clamp* Pg 107 Quantity of Clamps (If 1 leave blank) 2, 3, 4 (Specify # after clamp code) Bolt On Safety Clamps Q = 70BSC* Pg 94 Use with Series 70 couplings R = 80BSC* Pg 95 Use with Series 80 couplings Crimp Ferrules (Notched) S = TF Plated Steel Pg 108 T = TFS6 316SS Pg 108 Crimp Ferrules (No Notch) U = TSS Short, Plated Steel Pg 109 V = TSSS Short, 316SS Pg 109 W = TSL Long, Plated Steel Pg 110 X = TSLS Long, 316SS Pg 110 Other Y = Specify	Coupling Materials S1 = 301 Stainless Steel S2 = 201 Stainless Steel S3 = 303 Stainless Steel S4 = 304 Stainless Steel S6 = 316 Stainless Steel CS = Carbon Steel CP = Carbon Steel Plated BB = Brass NB = Brass Naval BR = Bronze AL = Aluminum AB = Aluminum Brass AM = Alum. Maleable Iron AH = Aluminum Hard Coat MI = Maleable Iron MP = Maleable Iron Plated MM = Monel NN = Nylon PP = Polypropylene X = Specify	Length Is standard in inches. For millimeters, place mm at the end of number.	Option - Accessories TBBV = Brass Ball Valves* Pg 160 TFV = Foot Valves Pg 161 TRHS = Round Hole Strainer Pg 161 TSHS = Square Hole Strainer Pg 161 TTS = Tube Strainer Pg 161 TTHS = Top Hole Strainer Pg 161 TBHS = Bottom Hole Strainer Pg 161 TSCS = Conical Strainer Pg 162 TPPS = Pump Plate Strainer Pg 162 TDM2000R = Pressure Washer Pg 163 TD230 = Cleaning Tool & Siphon Pg 163 TD212 = Strata-Flow Blow Gun Pg 163 TWA = Hose To Hose Whip Check Pg 165 TWB = Hose To Hose Whip Check Pg 165 TWSR = Hose To Tool Whip Check Pg 165 TWS = Whip Sock Pg 167 None = Leave Blank				

* Choose Material: (Place after Code) S6 = 316SS, CP = Plated Steel, BB = Brass, MI = Maleable Iron | Example NMI = Style 71 - 2 Bolt Clamp made of Maleable Iron

How To Order Thorburn Industrial Hose Assemblies

Hose Barb Series HB

001 - Style HB-MP = Male Insert	Pg 34
002 - Style HB-MP45 = Male Insert 45° Elbow	Pg 35
003 - Style HB-MP90 = Male Insert 90° Elbow	Pg 35
004 - Style HB-MS = Male 45° SAE	Pg 36
005 - Style HB-FSX = Female 45° SAE, 37" JIC	Pg 36
006 - Style HB-FP = Solid Female Insert	Pg 37
007 - Style HB-BJX = Female Swivel Gasket Seat	Pg 37
008 - Style HB-BSX = Female Swivel Ball Seat Swivel Nut	Pg 38
009 - Style HB-HM = Hose Barb Mender	Pg 38
010 - Style HB-HM90 = Hose Barb Mender 90° Elbow	Pg 39
011 - Style HB-HMT = Hose Barb Mender Tee	Pg 39

Qlaw™ Quick Acting Claw Coupling System

101 - Style 27 = Hose Shank with safety collar and safety pin holes - 2 Lug Type	Pg 40
102 - Style 29 = NPT Male with safety pin holes - 2 Lug Type	Pg 41
103 - Style 28 = NPT Female with safety pin holes - 2 Lug Type	Pg 41
104 - Style 33 = Blank Cap with safety pin holes - Complete with seal - 2 Lug Type	Pg 41
105 - Style 30 = Hose Shank with safety collar and safety pin holes - 4 Lug Type	Pg 42
106 - Style 31 = NPT Female with safety pin holes - 4 Lug Type	Pg 42
107 - Style 32 = Three way connector with safety pin holes - Complete with seal	Pg 42

Thor-Quick Dual Lock Safety Hose Couplings

201 - Style TQ-MP = Male NPT Pipe Plug	Pg 44
202 - Style TQ-FP = Female NPT Pipe Plug	Pg 44
203 - Style TQ-HB = Hose End Barb Coupler With Locking Sleeve	Pg 45
204 - Style TQ-MP-LS = Male NPT Pipe Thread Coupler With Locking Sleeve	Pg 45
205 - Style TQ-FP-LS = Female NPT Pipe Thread Coupler With Locking Sleeve	Pg 45

Thorburn Series BQC MacDonald Style Quick Action Couplings

301 - Style HM = Male Hose Stem	Pg 46
302 - Style HF = Female Hose Stem	Pg 46
303 - Style OM = Male BSPT Coupler	Pg 47
304 - Style OM = Male NPT Coupler	Pg 47
305 - Style OF = Male BSPT Plug	Pg 47
306 - Style OF = Male NPT Plug	Pg 48
307 - Style IM = Female BSPT Coupler	Pg 48
308 - Style IM = Female NPT Coupler	Pg 48
309 - Style IF = Female BSPT Plug	Pg 49
310 - Style IF = Female NPT Plug	Pg 49

Industrial Interchange Single Shut-Off Valve Couplings

401 - Style TDCP-HB = Standard Hose Barb Plug	Pg 50
402 - Style TDCP-PHB = Push-On Hose Barb Plug	Pg 50
403 - Style TDCP-MP = Male Pipe Thread	Pg 51
404 - Style TDCP-FP = Female Pipe Thread	Pg 51
405 - Style TDC-HB = Standard Hose Barb Coupler	Pg 52
406 - Style TDC-PHB = Push-On Hose Barb Coupler	Pg 52
407 - Style TDC-MP = Male Pipe Thread Coupler	Pg 53
408 - Style TDC-FP = Female Pipe Thread Coupler	Pg 53

Thorburn Single Shut-Off Valve Couplings

501 - Style T43C04-MP = Male NPT Valved Coupler 1/4" Body	Pg 54
502 - Style T43C04-FP = Female NPT Valved Coupler 1/4" Body	Pg 54
503 - Style T43C04-HS = Hose Stem Valved Coupler 1/4" Body	Pg 54
504 - Style T43P04-HS = Male NPT Non-Valved Plug 1/4" Body	Pg 55
505 - Style T43P04-FP = Female NPT Non-Valved Plug 1/4" Body	Pg 55
506 - Style T43P04-HS = Hose Stem Non-Valved Plug 1/4" Body	Pg 55
507 - Style T43C06-MP = Male NPT Valved Coupler 3/8" Body	Pg 56
508 - Style T43C06-FP = Female NPT Valved Coupler 3/8" Body	Pg 56
509 - Style T43C06-HS = Hose Stem Valved Coupler 3/8" Body	Pg 56
510 - Style T43P06-MP = Male NPT Non-Valved Plug 3/8" Body	Pg 57
511 - Style T43P06-FP = Female NPT Non-Valved Plug 3/8" Body	Pg 57
512 - Style T43P06-HS = Hose Stem Non-Valved Plug 3/8" Body	Pg 57

Air Hose Swivels

601 - Style TD22 = In-Line Swivels: Low Pressure (10 bar)	Pg 58
602 - Style (N)320T = Parallel Swivel: Low Pressure 360° Swivel Joint	Pg 58

Air Hose Manifolds

701 - Style TD23 = Two Connection Manifold	Pg 59
702 - Style TD34 = Three Connection Manifold	Pg 59
703 - Style TD35 = Three Connection Brass Flat Hex Manifold	Pg 59

Shank Couplings - Low Pressure

901 - Style 111C = Male NPT	Pg 60
902 - Style 111FS = Stub End for Floating Flanges	Pg 60
903 - Style 111V = Victaulic Grooved End	Pg 61
904 - Style 111W = Welded End	Pg 61
905 - Style 25I = Hose Mender	Pg 61

Thorburn Shank Couplings For Water Discharge and Suction Services

1001 - Style 14I = Complete Set	Pg 62
1002 - Style 15I = Female Half	Pg 63
1003 - Style 26I = Male Half	Pg 63

Thorburn Camlock Couplings

1101 - Style 633-C = Coupler Hose Shank	Pg 67
1102 - Style 633-E = Adapter Hose Shank	Pg 67
1103 - Style 633-B = Coupler Male NPT	Pg 68
1104 - Style 633-D = Coupler Female NPT	Pg 68
1105 - Style 633-A = Adapter Female NPT	Pg 69
1106 - Style 633-F = Adapter Male NPT	Pg 69
1107 - Style 633-DC = Dust Cap	Pg 70
1108 - Style 633-DP = Dust Plug	Pg 70
1109 - Style 633-PFC = Coupler Female Flange (Class 150)	Pg 71
1110 - Style 633-PFE = Adapter Male Flange (Class 150)	Pg 71
1111 - Style 733C-HD = High Pressure Coupler Hose Shank	Pg 73
1112 - Style 733D-HD = High Pressure Female NPT Coupler	Pg 73
1113 - Style 633A-HD = High Pressure Female NPT Adapter	Pg 73
1114 - Style 633FSW-HD = High Pressure Adapter To Socket Weld	Pg 73
1115 - Style 633FBW-HD = High Pressure Adapter To Butt Weld	Pg 73

Thorburn TB Bauer Type B Style Lever Couplings

1201 - Style TB309 = Male Hose Shank	Pg 74
1202 - Style TB310 = Female Hose Shank	Pg 74
1203 - Style TB311 = Male Socket with Male NPT	Pg 75
1204 - Style TB312 = Female Plug with Male NPT	Pg 75
1205 - Style TB313 = Male Socket with 150 ASA Flange	Pg 75
1206 - Style TB314 = Female Socket with 150 ASA Flange	Pg 76
1207 - Style TB308 = Female Plug with Gasket	Pg 76
1208 - Style TB304 = Lever Ring	Pg 76

Thorburn TP Perrot Type C Style Lever Couplings

1301 - Style TPKMS = Female Socket with Hose Stem	Pg 77
1302 - Style TPKVS = Male Plug with Hose Stem	Pg 77
1303 - Style TPKMG = Female Socket with Male NPT	Pg 79
1304 - Style TPKVG = Male Plug with Male NPT	Pg 79
1305 - Style TPKMF = Female Socket with 150 ASA Flange	Pg 79
1306 - Style TPKVF = Male Plug with 150 ASA Flange	Pg 80
1307 - Style TPKMR = Female End Cap	Pg 80
1307 - Style TPKVX = Male End Cap	Pg 80
1308 - Style TPKLR = Lever Ring	Pg 81

Series 70 Hose Couplings for Bolt-On Safety Clamps

1401 - Style 71TFBFF = Female - Smooth Stem (EN14420-5/DIN2817)	Pg 82
1402 - Style 72TFBFFS = Female - Serrated Stem (EN14420-5/DIN2817)	Pg 82
1403 - Style 73TFBFFM = Male - Smooth Stem (EN14420-5/DIN2817)	Pg 83
1404 - Style 74TFBFFS = Male - Serrated Stem (EN14420-5/DIN2817)	Pg 83
1405 - Style 75TFBFFL = Fixed Flange - Smooth Stem (EN14420-4/DIN2817)	Pg 84
1406 - Style 76TFBFFLS = Fixed Flange - Serrated Stem (EN14420-4/DIN2817)	Pg 84
1407 - Style 77TFBFFL = Swivel Flange - Smooth Stem (EN14420-4/DIN2817)	Pg 85
1408 - Style 78TFBFFLS = Swivel Flange - Serrated Stem (EN14420-4/DIN2817)	Pg 85

Series 80 Hose Couplings for Bolt-On Safety Clamps

1501 - Style 81TFBFF = Female - BSPP (EN14423/DIN2826)	Pg 86
1502 - Style 82TFBFFS = Male - BSPT (EN14423/DIN2826)	Pg 87
1503 - Style 83TFBFFM = Fixed Flange (EN14423/DIN2826)	Pg 87
1504 - Style 84TFBFFS = Swivel Flange (EN14423/DIN2826)	Pg 87

Thorburn Heavy Duty Ground Joint Couplings

1601 - Style 17I = Hose Stem with Wing Nut & Female Spud	Pg 88
1602 - Style 25I = Hose Stem with Wing Nut & Male Spud	Pg 89
1603 - Style 18I = Hose Stem	Pg 89
1604 - Style 19I = Wing Nut	Pg 90
1605 - Style 20I = Female Spud NPT	Pg 90
1606 - Style 21I = Male Spud NPT	Pg 90
1607 - Style 22I = Double Spud	Pg 91
1608 - Style 23I = Male Spud NPT Stem	Pg 91
1609 - Style 24I = Hose Splice (No Clamp)	Pg 91

Thorburn Series 70BSC - Bolt-On Safety Clamps



Standard Service EN 14420-3 / DIN 2817 Bolt-On Safety Clamps

Thorburn Series 70BSC Bolt-On Safety Clamps are constructed as a two piece shell type EN 14420-3/DIN 2817 clamp, and are specifically designed for use with EN 14420-5 hose couplings and EN 14420-4 flange hose couplings with smooth or serrated stems with a safety collar. Thorburn Bolt-On Safety Clamps are designed with a rim on the inside, which fits over the hose tail collar when the bolts are tightened. When the safety clamps are assembled correctly, the coupling cannot be pulled out of the hose and will stay secure up to and including the burst pressure of the hose assembly. Thorburn Series 70BSC Bolt-On Safety Clamps are commonly used in industries such as chemical processing, oil and gas, food and beverage, and pharmaceuticals and is suitable for connecting hoses or pipes carrying fluids such as water, chemicals, gases, and powders.

Style 70BSC | Bolt-On Safety Clamp



Construction

Normative Regulation:

EN 14420-3/DIN 2817

Sizes: From DN 15 up to DN 250

Coupling Material:

Aluminum, Stainless Steel, Brass

Operating Temperature:

-20°C/-4 °F to + 65°C/149°F

Working Pressure:

-0.8 bar / -11 psi up to 25 bar/360 psi

Connection Mechanism:

Assembly into EN 14420-5 hose couplings (Pg 82) or EN 14420-4 hose flange couplings (Pg 84)

Thorburn Part #			Hose OD		Bolt Thread
Aluminum	Brass	316SS	Min	Max	mm
70BSC22X24-AL	70BSC22X24-BB	70BSC22X24-S6	22	24	M6*20
70BSC30X33-AL	70BSC30X33-BB	70BSC30X33-S6	30	33	M6*20
70BSC28X30-AL	70BSC28X30-BB	70BSC28X30-S6	28	30	M6*20
70BSC34X36-AL	70BSC34X36-BB	70BSC34X36-S6	34	36	M6*20
70BSC36X39-AL	70BSC36X39-BB	70BSC36X39-S6	36	39	M6*20
70BSC40X43-AL	70BSC40X43-BB	70BSC40X43-S6	40	43	M6*20
70BSC41X44-AL	70BSC41X44-BB	70BSC41X44-S6	41	44	M6*20
70BSC43X46-AL	70BSC43X46-BB	70BSC43X46-S6	43	46	M6*20
70BSC47X50-AL	70BSC47X50-BB	70BSC47X50-S6	47	50	M6*20
70BSC50X52-AL	70BSC50X52-BB	70BSC50X52-S6	50	52	M6*20
70BSC53X56-AL	70BSC53X56-BB	70BSC53X56-S6	53	56	M6*20
70BSC57X60-AL	70BSC57X60-BB	70BSC57X60-S6	57	60	M6*20
70BSC58X61-AL	70BSC58X61-BB	70BSC58X61-S6	58	61	M6*20
70BSC59X62-AL	70BSC59X62-BB	70BSC59X62-S6	59	62	M8*25
70BSC60X64-AL	70BSC60X64-BB	70BSC60X64-S6	60	64	M8*25
70BSC61X65-AL	70BSC61X65-BB	70BSC61X65-S6	61	65	M8*25
70BSC63X67-AL	70BSC63X67-BB	70BSC63X67-S6	63	67	M8*25
70BSC69X71-AL	70BSC69X71-BB	70BSC69X71-S6	69	71	M8*25
70BSC74X77-AL	70BSC74X77-BB	70BSC74X77-S6	74	77	M8*25
70BSC84X87-AL	70BSC84X87-BB	70BSC84X87-S6	84	87	M8*25
70BSC87X90-AL	70BSC87X90-BB	70BSC87X90-S6	87	90	M8*25
70BSC89X92-AL	70BSC89X92-BB	70BSC89X92-S6	89	92	M8*25
70BSC89X93-AL	70BSC89X93-BB	70BSC89X93-S6	89	93	M8*25
70BSC94X97-AL	70BSC94X97-BB	70BSC94X97-S6	94	97	M8*25
70BSC114X119-AL	70BSC114X119-BB	70BSC114X119-S6	114	119	M10*40
70BSC118X122-AL	70BSC118X122-BB	70BSC118X122-S6	118	122	M10*40
70BSC122X126-AL	70BSC122X126-BB	70BSC122X126-S6	122	126	M10*40
70BSC143X148-AL	70BSC143X148-BB	70BSC143X148-S6	143	148	M10*40
70BSC168X174-AL	70BSC168X174-BB	70BSC168X174-S6	168	174	M12*50
70BSC174X180-AL	70BSC174X180-BB	70BSC174X180-S6	174	180	M12*50
70BSC187X193-AL	70BSC187X193-BB	70BSC187X193-S6	187	193	M12*51
70BSC222X229-AL	70BSC222X229-BB	70BSC222X229-S6	222	229	M12*60
70BSC274X278-AL	70BSC274X278-BB	70BSC274X278-S6	274	278	M12*60

Thorburn Series 80BSC - Bolt-On Safety Clamps



Steam Service EN 14423 / DIN 2826 Bolt-On Safety Clamps

Thorburn Series 80BSC Bolt-On Safety Clamps are constructed as a two piece shell type EN 14423/DIN 2826 clamp, and are specifically designed for use with EN 14423 hose couplings for steam service. Thorburn 80BSC Bolt-On Safety Clamps have a rim on the inside, which fits the hose shank collar when the bolts are tightened stopping the coupling from being pulled out of the hose.

Application

- Steam and hot water use
- Food
- Pharmaceutical Industry
- Transport Industry

Style 80BSC | Bolt-On Safety Clamp



Thorburn Part #		Hose OD	
316SS	Brass	Min	Max
80BSC24X26-S6	80BSC24X26-BB	24	26
80BSC32X34-S6	80BSC32X34-BB	32	34
80BSC39X41-S6	80BSC39X41-BB	39	41
80BSC47X50-S6	80BSC47X50-BB	47	50
80BSC53X56-S6	80BSC53X56-BB	53	56
80BSC67X69-S6	80BSC67X69-BB	67	69

WARNING: Steam is dangerous. Never use quick-release couplings for steam applications. Extra care and attention should be taken when choosing the correct hose, fitting and clamping solution

Construction

Normative Regulation:

EN 14423 previous DIN 2826

Sizes: From DN 13 up to DN 50

Coupling Material: Stainless Steel, Brass

Operating Temperature:

Steam: 210°C (410°F)

Hot Water: 120°C (248°F)

Working Pressure:

18 bar (261 psi)

Connection Mechanism:

Assembly into EN 14423 hose couplings (Pg 86)

Thorburn Series TBRC Pipe Repair Clamps



Stainless steel band repair clamp/pipe leak repair clamp

Thorburn Series TBRC Pipe Repair Clamps are the connecting agents during any pipe repair fiasco. Pipe repair is of the utmost importance, since the production process needs to resume as soon as possible. Power plants, waste water treatment plants, material processing plants and oil and gas production plants need an expedient pipe repair system in order to function smoothly and efficiently. Thorburn Series TBRC Pipe Repair Clamps stabilize the operation of damaged, corrosive, cracked or ruptured pipes and fill pipe gaps and openings. They are a highly cost effective solution since they cut down on time, expenditure and energy.

Features

- Clamp is light and easy to carry, and can be used in narrow spaces.
- Simple to set up and requires no downtime
- Guarantees a tight, leak-proof sealing
- Fixes pipeline damage, leaks, and cracks
- Offers a fast and efficient way to restore pipe integrity
- Suitable for plastic/metal pipe leakage repair
- Pressures up to 20Bar (300PSI)
- Temperature range of -12°C (10°F) to 93°C (200°F)

Thorburn Series TBRC Components and Materials

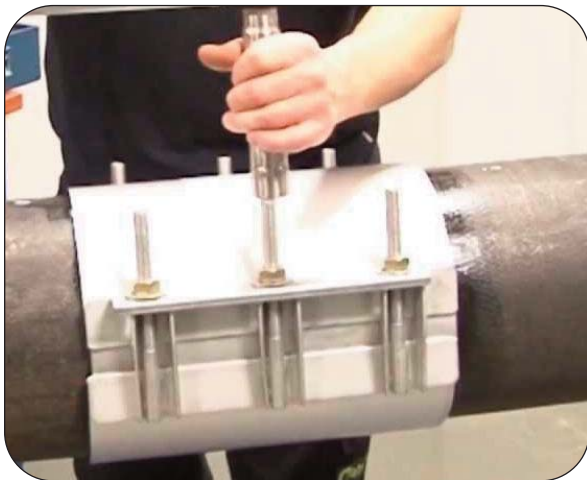

Materials (Standard)

Rubber Sealing Sleeve: NBR

Outer Clamp Casing: SS304

(Other Materials available on special order - Minimum Quantities may apply)

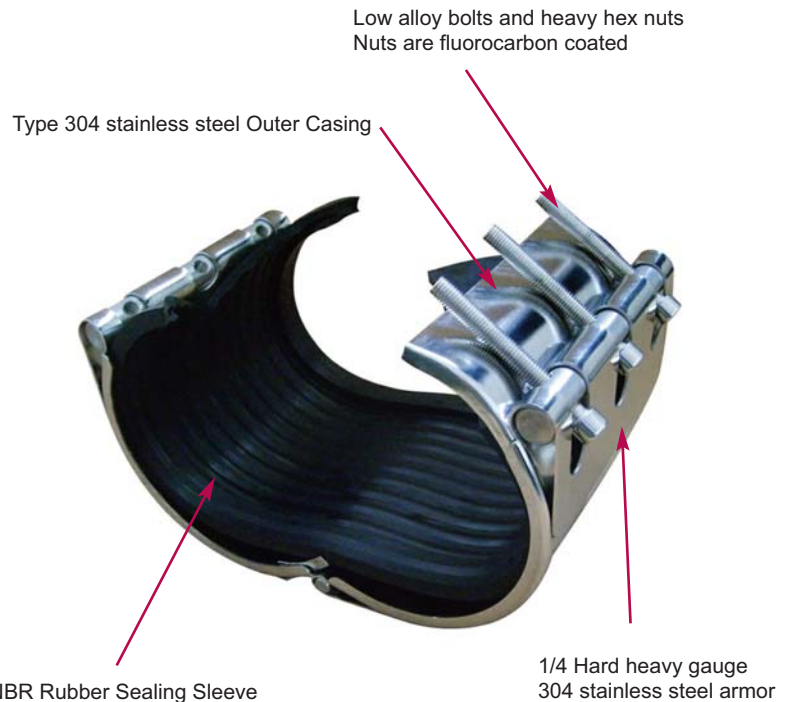

Thorburn Series TBRC Pipe Repair Clamp Specifications

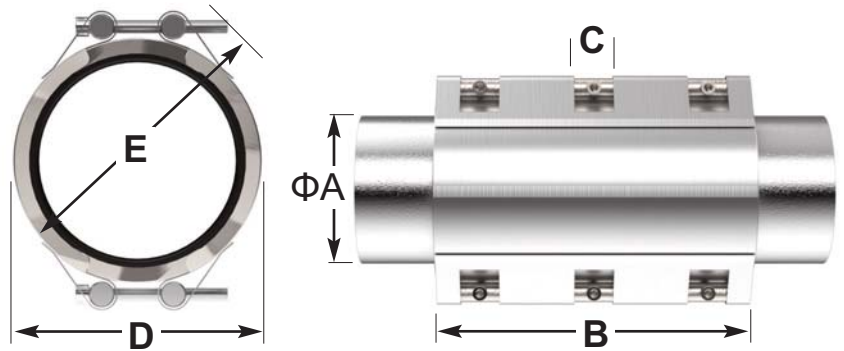

Thorburn Part #	Clamping Range	Tube Diameter	Pressure	C Max		C Max			Bolt	Install Torque
	ΦA (mm)	mm		mm	mm	B (mm)	D (mm)	E (mm)		
TBRC-27-D-S4	26.4-27.4	26.9	25	5	5	62	43	70	8	10
TBRC-30-D-S4	29.5-30.5	30.0	25	5	5	62	47	75	8	10
TBRC-34-D-S4	33.2-34.2	33.7	25	5	5	62	51	75	8	10
TBRC-38-D-S4	37.5-38.5	38.0	25	5	10	62	57	90	8	15
TBRC-42-D-S4	41.9-42.9	42.4	25	5	10	62	62	95	8	15
TBRC-45-D-S4	44.0-45.0	44.5	25	5	10	62	64	95	8	15
TBRC-48-D-S4	47.8-48.8	48.3	25	5	10	62	67	100	8	15
TBRC-54-D-S4	53.5-54.5	54.0	25	8	15	75	76	105	8	15
TBRC-57-D-S4	56.4-57.8	57.0	25	8	15	75	76	105	8	15
TBRC-60-D-S4	59.7-60.9	60.3	25	8	15	75	79	110	8	15
TBRC-67-D-S4	64.9-67.3	66.6	20	8	15	105	87	126	8	15
TBRC-70-D-S4	68.9-70.7	70.0	20	10	25	105	92	131	8	20
TBRC-73-D-S4	72.3-73.7	73.0	20	10	25	105	96	142	8	20
TBRC-76-D-S4	75.3-76.9	76.1	20	10	25	105	98	142	8	20
TBRC-84-D-S4	83.2-84.8	84.0	20	10	25	105	112	152	8	20
TBRC-89-D-S4	88.0-89.8	88.9	20	10	25	105	113	157	8	20
TBRC-102-D-S4	100.6-102.6	101.6	20	10	25	120	130	172	10	25
TBRC-105-D-S4	103.8-105.8	104.8	20	10	25	120	132	172	10	25
TBRC-108-D-S4	106.9-109.1	108.0	20	10	25	120	135	172	10	25
TBRC-114-D-S4	113.2-115.4	114.3	20	10	25	120	136	177	10	25
TBRC-127-D-S4	125.7-128.3	127.0	16	10	25	120	151	195	10	40
TBRC-129-D-S4	127.7-130.3	129.0	16	10	25	120	153	195	10	40
TBRC-133-D-S4	131.7-134.3	133.0	16	10	30	120	157	200	10	40
TBRC-140-D-S4	138.3-141.1	139.7	16	10	30	120	164	210	10	40
TBRC-141-D-S4	139.9-142.7	141.3	16	10	30	120	166	210	10	40
TBRC-154-D-S4	152.5-155.5	154.0	16	10	30	120	184	225	10	40
TBRC-159-D-S4	157.4-160.6	159.0	16	10	30	120	186	225	10	40
TBRC-168-D-S4	166.6-170.0	168.3	16	10	30	120	192	230	10	40
TBRC-219-D-S4	216.9-221.3	219.1	12	10	35	152	250	295	12	50
TBRC-273-D-S4	270.5-275.5	273.0	12	10	35	152	303	345	12	50
TBRC-324-D-S4	320.5-327.0	323.9	12	10	35	152	354	395	12	70

Thorburn Worm Gear Clamps



Thorburn worm gear hose clamps are used to attach and seal a hose with a 360° compression force on all sides, with no gaps, onto a shank or barb fitting to ensure a leak tight seal. Thorburn worm gear hose clamps are typically limited to pressures not exceeding 150 psi (10 bar). For high pressure applications Thorburn’s crimp fittings are used.

Style 60CHS | Worm Gear Clamps



Materials: Standard type - Series 301 stainless band and housing, SAE 1018 case-hardened carbon steel, zinc plated and chromate dipped screw.

Style 61CHAS | Worm Gear Clamps



Materials: Standard type – All stainless steel – SAE 301 series stainless band and hosing, SAE 305 series stainless screw.

Stainless Steel 301SS		Hose Diameter Range OD			
		Minimum		Maximum	
		mm	in	mm	in
60CHS02-S1	61CHAS02-S1	6	0.25	16	0.63
60CHS04-S1	61CHAS04-S1	8	0.31	22	0.88
60CHS06-S1	61CHAS06-S1	10	0.38	22	0.88
60CHS08-S1	61CHAS08-S1	11	0.44	25	1.00
60CHS10-S1	61CHAS10-S1	14	0.56	27	1.06
60CHS12-S1	61CHAS12-S1	14	0.56	29	1.13
60CHS16-S1	61CHAS16-S1	18	0.69	38	1.50
60CHS20-S1	61CHAS20-S1	19	0.75	44	1.75
60CHS24-S1	61CHAS24-S1	30	1.06	51	2.00
60CHS28-S1	61CHAS28-S1	33	1.31	57	2.25
60CHS32-S1	61CHAS32-S1	40	1.56	64	2.50
60CHS36-S1	61CHAS36-S1	46	1.81	70	2.75
60CHS40-S1	61CHAS40-S1	52	2.06	76	3.00
60CHS44-S1	61CHAS44-S1	59	2.31	83	3.25
60CHS48-S1	61CHAS48-S1	65	2.56	89	3.50
60CHS52-S1	61CHAS52-S1	71	2.81	95	3.75
60CHS56-S1	61CHAS56-S1	78	3.06	102	4.00
60CHS60-S1	61CHAS60-S1	84	3.31	105	4.13
60CHS64-S1	61CHAS64-S1	90	3.56	114	4.50
60CHS72-S1	61CHAS72-S1	105	4.13	127	5.00
60CHS84-S1	61CHAS84-S1	125	4.94	146	5.75
60CHS88-S1	61CHAS88-S1	108	4.25	152	6.00
60CHS96-S1	61CHAS96-S1	114	4.50	164	6.44
60CHS104-S1	61CHAS104-S1	127	5.00	178	7.00
60CHS128-S1	61CHAS128-S1	165	6.50	216	8.50
60CHS152-S1	61CHAS152-S1	207	8.13	254	10.00
60CHS188-S1	61CHAS188-S1	276	10.88	311	12.25
60CHS200-S1	61CHAS200-S1	279	11.00	330	13.00
60CHS212-S1	61CHAS212-S1	298	11.75	349	13.75
60CHS224-S1	61CHAS224-S1	318	12.50	368	14.50
60CHS236-S1	61CHAS236-S1	337	13.25	387	15.25
60CHS248-S1	61CHAS248-S1	356	14.00	406	16.00
60CHS312-S1	61CHAS312-S1	457	18.00	508	20.00

Thorburn Two Ear Clamps and Accessories

Style 62CC | Two Ear Clamp



Wider clamping range than a single ear clamp
Materials: Plated steel

Plated Steel	Nominal Size	Hose Diameter Range OD			
		Minimum		Maximum	
		mm	in	mm	in
62CC0041-CP	5/32	3	0.12	4	0.16
62CC0045-CP	11/64	4	0.14	5	0.18
62CC0305-CP	3/16	3	0.12	5	0.20
62CC0507-CP	1/4	5	0.20	7	0.28
62CC0709-CP	5/16	7	0.28	9	0.35
62CC0811-CP	3/8	8	0.32	11	0.43
62CC0911-CP	7/16	9	0.35	11	0.43
62CC1113-CP	1/2	11	0.43	13	0.51
62CC1315-CP	9/16	13	0.51	15	0.59
62CC1517-CP	19/32	15	0.59	17	0.67
62CC1518-CP	5/8	15	0.59	18	0.71
62CC1720-CP	3/4	17	0.67	20	0.79
62CC1922-CP	13/16	19	0.75	22	0.87
62CC2023-CP	7/8	20	0.79	23	0.91
62CC2225-CP	15/16	22	0.87	25	0.98
62CC2327-CP	1	23	0.91	27	1.06
62CC2528-CP	1 1/16	25	0.98	28	1.10
62CC2731-CP	1 1/8	27	1.06	31	1.22
62CC2831-CP	1 3/16	28	1.10	31	1.22
62CC3134-CP	1 5/16	31	1.22	34	1.34
62CC3437-CP	1 7/16	34	1.34	37	1.46
62CC3740-CP	1 1/2	37	1.46	40	1.58
62CC4043-CP	1 5/8	40	1.58	43	1.69
62CC4346-CP	1 3/4	43	1.69	46	1.81

Style 62CC | Ear Clamp Pincers



Thorburn Preformed Clamps and Accessories

Style 65C | Preformed "Fast Lock" Clamps & Accessories



Type "CK" clamp is a preformed clamp with a special buckle which permits this clamp to be tightened and locked with not only Thorburn's 68CF1 tool, but with other makes as well.
Materials: Plated carbon steel and 316 Stainless steel

Plated Steel Part #	Stainless Steel 316SS Part #	Size ID		Standard Pack QTY
		mm	in	
65CK04-CP	65CKS04-S6	25	1	100
65CK05-CP	65CKS05-S6	32	1 1/4	100
65CK06-CP	65CKS06-S6	38	1 1/2	100
65CK07-CP	65CKS07-S6	45	1 3/4	100
65CK08-CP	65CKS08-S6	51	2	100
65CK09-CP	65CKS09-S6	57	2 1/4	100
65CK10-CP	65CKS10-S6	64	2 1/2	50
65CK11-CP	65CKS11-S6	70	2 3/4	50
65CK12-CP	65CKS12-S6	76	3	50
65CK14-CP	65CKS14-S6	89	3 1/2	50
65CK16-CP	65CKS16-S6	102	4	25
65CK18-CP	65CKS18-S6	114	4 1/2	25
65CK20-CP	65CKS20-S6	127	5	25
65CK24-CP	65CKS24-S6	152	6	25
65CK32-CP	65CKS32-S6	203	8	25

Style 66C | Field Installation Clamping - Bulk Strapping



Bulk strapping provides separate stainless steel or galvanized steel strapping in 4 widths and in 100 ft. rolls with clamp buckles of corresponding widths in 50 through 300 piece quantities and a special Jack-type clamping tool Thorburn number 68C2 for use on all widths with adjustable tensioning.

Part #	Width		Thickness		Material
	mm	in	mm	in	
66C06-S6	10	3/8	0.64	0.025	316SS
66C08-S6	12	1/2	0.76	0.030	316SS
66C10-S6	16	5/8	0.76	0.030	316SS
66C12-S6	20	3/4	0.76	0.030	316SS
66C06-S2	10	3/8	0.64	0.025	201SS
66C08-S2	12	1/2	0.76	0.030	201SS
66C10-S2	16	5/8	0.76	0.030	201SS
66C12-S2	20	3/4	0.76	0.030	201SS
66C06-CP	10	3/8	0.64	0.025	Galvanized
66C08-CP	12	1/2	0.76	0.030	Galvanized
66C10-CP	16	5/8	0.76	0.030	Galvanized
66C12-CP	20	3/4	0.76	0.030	Galvanized

Thorburn Preformed Clamps and Accessories

Style 67C | Field Installation Clamping - Buckles



Provides separate stainless steel or galvanized steel strapping in 4 widths and in 100 ft. rolls with clamp buckles of corresponding widths in 50 through 300 piece quantities and a special Jack-type clamping tool Thorburn number 68C2 for use on all widths with adjustable tensioning.

Part #	Width		Thickness		Material	Box
	mm	in	mm	in		QTY
67C06-S6	10	3/8	0.64	0.025	316SS	300
67C08-S6	12	1/2	0.76	0.030	316SS	150
67C10-S6	16	5/8	0.76	0.030	316SS	100
67C12-S6	20	3/4	0.76	0.030	316SS	75
67C06-S2	10	3/8	0.64	0.025	201SS	300
67C08-S2	12	1/2	0.76	0.030	201SS	150
67C10-S2	16	5/8	0.76	0.030	201SS	100
67C12-S2	20	3/4	0.76	0.030	201SS	75
67C06-CP	10	3/8	0.64	0.025	Galvanized	300
67C08-CP	12	1/2	0.76	0.030	Galvanized	150
67C10-CP	16	5/8	0.76	0.030	Galvanized	100
67C12-CP	20	3/4	0.76	0.030	Galvanized	75

Style 68C | Fast Lock Tools & Accessories



Thorburn Bolt Clamps

Style 69C | Single Bolt Clamp



APPLICATION

May be used on low or medium pressure hose with such couplings as long shank, short shank, combination nipples or scored nipples.

Material: Plated carbon steel.

Plated Steel	Size	Hose Diameter Range OD				Width	
		Minimum		Maximum			
	mm	mm	in	mm	in	mm	in
69C-68-CP	68-73	68	2.68	74	2.90	24	0.94
69C-74-CP	74-79	74	2.91	80	3.14	24	0.94
69C-80-CP	80-85	80	3.15	86	3.38	24	0.94
69C-86-CP	86-91	86	3.39	92	3.61	24	0.94
69C-92-CP	92-97	92	3.62	98	3.85	24	0.94
69C-98-CP	98-103	98	3.86	104	4.08	24	0.94
69C-104-CP	104-112	104	4.09	113	4.44	24	0.94
69C-113-CP	113-121	113	4.45	122	4.79	24	0.94
69C-122-CP	122-130	123	4.80	131	5.15	24	0.94
69C-131-CP	131-139	131	5.16	140	5.50	26	1.02
69C-140-CP	140-148	140	5.51	149	5.86	26	1.02
69C-149-CP	149-161	150	5.87	162	6.37	26	1.02
69C-162-CP	162-174	162	6.38	175	6.88	26	1.02
69C-175-CP	175-187	175	6.89	188	7.39	26	1.02
69C-188-CP	188-200	188	7.40	200	7.86	26	1.02
69C-201-CP	201-213	201	7.91	214	8.42	26	1.02
69C-214-CP	214-226	214	8.43	226	8.90	26	1.02
69C-227-CP	227-239	227	8.94	240	9.44	26	1.02
69C-240-CP	240-252	240	9.45	252	9.92	26	1.02
69C-248-CP	248-260	248	9.76	260	10.24	26	1.02

Style 70C | Double Bolt Clamp



APPLICATION

For heavy-duty applications with larger sizes of combination nipples, pipe nipples, or pin lugs.

Material: Plated carbon steel.

Plated Steel	Size	Hose Diameter Range OD				Width	
		Minimum		Maximum			
	mm	mm	in	mm	in	mm	in
70C-86-CP	86-91	86	3.39	92	3.61	24	0.94
70C-92-CP	92-97	92	3.62	98	3.85	24	0.94
70C-98-CP	98-103	98	3.86	104	4.08	24	0.94
70C-104-CP	104-112	104	4.09	113	4.44	24	0.94
70C-113-CP	113-121	113	4.45	122	4.79	24	0.94
70C-122-CP	122-130	123	4.80	131	5.15	24	0.94
70C-131-CP	131-139	131	5.16	140	5.50	26	1.02
70C-140-CP	140-148	140	5.51	149	5.86	26	1.02
70C-149-CP	149-161	149	5.87	162	6.37	26	1.02
70C-162-CP	162-174	162	6.38	175	6.88	26	1.02
70C-175-CP	175-187	175	6.89	188	7.39	26	1.02
70C-188-CP	188-200	188	7.40	200	7.86	26	1.02
70C-200-CP	200-220	200	7.87	220	8.66	26	1.02
70C-220-CP	220-240	220	8.66	215	9.45	26	1.02
70C-240-CP	240-260	240	9.45	260	10.24	26	1.02
70C-260-CP	260-280	260	10.24	280	11.02	26	1.02
70C-280-CP	280-300	280	11.02	300	11.81	26	1.02
70C-300-CP	300-325	300	11.81	325	12.80	26	1.02
70C-325-CP	325-350	325	12.80	350	13.78	26	1.02
70C-350-CP	350-375	350	13.78	375	14.76	26	1.02
70C-375-CP	375-400	375	14.76	400	15.75	26	1.02
70C-400-CP	400-425	400	15.75	425	16.73	26	1.02
70C-425-CP	425-450	425	16.73	450	17.72	26	1.02
70C-450-CP	450-475	450	17.72	475	18.70	26	1.02

Thorburn Bolt Clamps

Style 71C | Stainless Bolt Clamp



APPLICATION

May be used on low or medium pressure hose with such couplings as long shank, short shank, combination nipples or scored nipples.

Material: Stainless Steel

Stainless Steel 316SS	Size	Hose Diameter Range OD				Width	
		Minimum		Maximum			
	mm	mm	in	mm	in	mm	in
71C-32-S6	32-35	32	1.26	36	1.41	20	0.79
71C-36-S6	36-39	36	1.42	40	1.56	20	0.79
71C-40-S6	40-43	40	1.57	44	1.72	22	0.87
71C-44-S6	44-47	44	1.73	48	1.88	22	0.87
71C-48-S6	48-51	48	1.89	52	2.04	22	0.87
71C-52-S6	52-55	52	2.05	55	2.17	22	0.87
71C-56-S6	56-59	56	2.20	60	2.35	22	0.87
71C-60-S6	60-63	60	2.36	64	2.51	22	0.87
71C-64-S6	64-67	64	2.52	68	2.67	24	0.94
71C-68-S6	68-73	68	2.68	74	2.90	24	0.94
71C-74-S6	74-79	74	2.91	80	3.14	24	0.94
71C-80-S6	80-85	80	3.15	86	3.38	24	0.94
71C-86-S6	86-91	86	3.39	92	3.61	24	0.94
71C-92-S6	92-97	92	3.62	98	3.85	24	0.94
71C-98-S6	98-103	98	3.86	104	4.08	24	0.94
71C-104-S6	104-112	104	4.09	113	4.44	24	0.94
71C-113-S6	113-121	113	4.45	122	4.79	24	0.94
71C-122-S6	122-130	122	4.80	131	5.15	24	0.94
71C-131-S6	131-139	131	5.16	140	5.50	26	1.02
71C-140-S6	140-148	140	5.51	149	5.86	26	1.02
71C-149-S6	149-161	149	5.87	162	6.37	26	1.02
71C-162-S6	162-174	162	6.38	175	6.88	26	1.02

Style 72C | Stainless Constant Tension Clamp



APPLICATION

Provides excellent 360° seal and has a spring that automatically adjusts the clamp diameter to compensate for hose expansion and contraction.

Material: Stainless Steel

Stainless Steel 316SS	Size	Hose Diameter Range OD				Width	
		Minimum		Maximum			
	mm	mm	in	mm	in	mm	in
72C-65-S6	58-65	58	2.28	65	2.56	19	0.75
72C-68-S6	60-68	60	2.36	68	2.68	19	0.75
72C-75-S6	67-75	67	2.63	75	2.95	19	0.75
72C-81-S6	73-81	73	2.87	81	3.19	19	0.75
72C-87-S6	79-87	79	3.11	87	3.43	19	0.75
72C-100-S6	92-100	92	3.62	100	3.94	19	0.75
72C-113-S6	105-113	105	4.13	113	4.45	19	0.75
72C-119-S6	111-119	111	4.37	118	4.66	19	0.75
72C-125-S6	117-125	117	4.61	125	4.92	19	0.75
72C-138-S6	130-138	130	5.12	138	5.43	19	0.75
72C-151-S6	143-151	143	5.63	151	5.94	19	0.75
72C-167-S6	159-167	160	6.26	167	6.57	19	0.75

Thorburn Spiral Clamps



Thorburn Spiral Clamps are used on convoluted hoses. To determine which type of spiral clamp is required you must examine the end of the hose to view the spiral helix reinforcement. If the helix spirals in a clockwise direction away from you, a clockwise spiral clamp is needed. If the helix spirals in a counterclockwise direction away from you, a counterclockwise spiral clamp is needed.

Style 770CX | Spiral Clamps - Clockwise Wound



Plated Steel	Size	Hose Diameter Range OD			
		Minimum		Maximum	
	in	mm	in	mm	in
770CX32-CP	2	58	2 - 18/64	64	2 - 32/64
770CX40-CP	2 1/2	69	2 - 46/64	79	3 - 8/64
770CX48-CP	3	76	3	89	3 - 32/64
770CX64-CP	4	102	4	114	4 - 32/64
770CX80-CP	5	129	5 - 6/64	140	5 - 32/64
770CX96-CP	6	159	6 - 16/64	178	7
770CX128-CP	8	216	8 - 32/64	235	9 - 16/64
770CX160-CP	10	270	10 - 40/64	286	11 - 16/64

Material: Plated carbon steel

Style 771CX | Spiral Clamps - Counter Clockwise Wound



Plated Steel	Size	Hose Diameter Range OD			
		Minimum		Maximum	
	in	mm	in	mm	in
771CX32-CP	2	58	2 - 18/64	64	2 - 32/64
771CX40-CP	2 1/2	69	2 - 46/64	79	3 - 8/64
771CX48-CP	3	76	3	89	3 - 32/64
771CX64-CP	4	102	4	114	4 - 32/64
771CX80-CP	5	129	5 - 6/64	140	5 - 32/64
771CX96-CP	6	159	6 - 16/64	178	7
771CX128-CP	8	216	8 - 32/64	235	9 - 16/64
771CX160-CP	10	270	10 - 40/64	286	11 - 16/64

Material: Plated carbon steel

Thorburn Perma-Clamps

Style 777C | Perma-Clamp



Material: Plated carbon steel

FEATURES

- 100% stainless steel construction
- 3/4" wide band
- Double banded for durability
- Easily installed without removing hoses
- 2 ply band for even distribution of torque
- Full range of sizes– 1.5" to 10"
- Larger sizes available upon request
- Ideal for hoses, filter bags and marine engine installations

Plated Steel	Size	Hose Diameter Range OD				Width	
		Minimum		Maximum			
	mm	mm	in	mm	in	mm	in
777C-19-CP	17-19	17	0.67	19	0.75	26	1.02
777C-22-CP	20-22	20	0.79	22	0.87	26	1.02
777C-25-CP	23-25	23	0.87	25	0.98	26	1.02
777C-28-CP	26-28	26	1.02	28	1.10	26	1.02
777C-31-CP	29-31	29	1.14	31	1.22	26	1.02
777C-35-CP	32-35	32	1.26	35	1.38	26	1.02
777C-39-CP	36-39	36	1.42	39	1.54	26	1.02
777C-43-CP	40-43	40	1.57	43	1.69	22	0.87
777C-47-CP	44-47	44	1.73	47	1.85	22	0.87
777C-51-CP	48-51	48	1.89	51	2.01	22	0.87
777C-55-CP	52-55	52	2.05	55	2.17	22	0.87
777C-59-CP	56-59	56	2.20	59	2.32	22	0.87
777C-63-CP	60-63	60	2.36	63	2.48	22	0.87
777C-67-CP	64-67	64	2.52	67	2.64	24	0.94
777C-73-CP	68-73	68	2.68	73	2.87	24	0.94
777C-79-CP	74-79	74	2.91	79	3.11	24	0.94
777C-85-CP	80-85	80	3.15	85	3.35	24	0.94
777C-91-CP	86-91	86	3.39	91	3.58	24	0.94
777C-97-CP	92-97	92	3.62	97	3.62	24	0.94
777C-103-CP	98-103	98	3.86	103	4.06	24	0.94
777C-112-CP	104-112	104	4.09	112	4.41	24	0.94
777C-121-CP	113-121	113	4.45	121	4.76	24	0.94
777C-130-CP	122-130	122	4.80	130	5.12	24	0.94
777C-139-CP	131-139	131	5.16	139	5.47	26	1.02
777C-148-CP	140-148	140	5.51	148	5.83	26	1.02
777C-161-CP	149-161	149	5.87	161	6.34	26	1.02
777C-174-CP	162-174	162	6.38	174	6.85	26	1.02
777C-187-CP	175-187	175	6.89	187	7.36	26	1.02
777C-200-CP	188-200	188	7.40	200	7.87	26	1.02
777C-213-CP	201-213	201	7.91	213	8.39	26	1.02
777C-226-CP	214-226	214	8.43	226	8.90	26	1.02
777C-239-CP	227-239	227	8.94	239	9.41	26	1.02
777C-252-CP	240-252	240	9.45	252	9.92	26	1.02

Thorburn Hose & Bag Clamps

Style 778C | Hose Clamp



Material: 304 Stainless Steel

FEATURES

- Used for permanent or semipermanent applications
- Hex head for wrench to obtain maximum torque
- Parallel take-up
- Quick release action
- 1 piece construction
- 304 stainless steel
- 1" wide band

Stainless Steel 304SS	Hose OD	
	mm	in
778C-48-S4	76	3
778C-56-S4	89	3.5
778C-64-S4	102	4
778C-72-S4	114	4.5
778C-80-S4	127	5
778C-88-S4	140	5.5
778C-96-S4	152	6
778C-104-S4	165	6.5
778C-128-S4	203	8
778C-134-S4	216	8.5
778C-160-S4	254	10
778C-176-S4	279	11
778C-192-S4	305	12

Style 779C | Bag Clamp



Material: 304 Stainless Steel

FEATURES

- "T" handle for quick "by hand" tightening and removal
- 3" OD minimum size
- 1 piece construction
- 304 stainless steel
- 1" wide band

Stainless Steel 304SS	Hose OD	
	mm	in
779C-48-S4	76	3
779C-56-S4	89	3.5
779C-64-S4	102	4
779C-72-S4	114	4.5
779C-80-S4	127	5
779C-88-S4	140	5.5
779C-96-S4	152	6
779C-104-S4	165	6.5
779C-128-S4	203	8
779C-134-S4	216	8.5
779C-160-S4	254	10
779C-176-S4	279	11
779C-192-S4	305	12

Thorburn High Pressure Interlocking Clamps

APPLICATIONS: For use with interlocking type inserts or universal quick-acting couplings for heavy duty high pressure applications.

MATERIALS: Cast malleable iron, Brass, Stainless Steel

Style 71 | 2 Bolt Clamp



Part #			Hose ID	Hose Diameter Range OD			
Maleable Iron	Brass	316SS		Minimum		Maximum	
			in	mm	in	mm	in
71C209-MI	-	-	1/4	14	0.56	17	0.66
71C211-MI	-	-	3/8	18	0.69	22	0.88
71C213-MI	-	-	1/2	21	0.81	24	0.94
71C215-MI	71C215-BB	71C215-S6	1/2	24	0.94	27	1.06
71C217-MI	-	-	1/2	27	1.06	30	1.19
71C219-MI	71C219-BB	71C219-S6	3/4	21	0.81	24	0.94
71C221-MI	71C221-BB	71C221-S6	3/4	33	1.31	38	1.50
71C224-MI	-	-	3/4	38	1.50	43	1.69

Style 72 | 4 Bolt Clamp



Part #			Hose ID	Hose Diameter Range OD			
Maleable Iron	Brass	316SS		Minimum		Maximum	
			in	mm	in	mm	in
72C417-MI	72C417-BB	72C417-S6	1	39	1.53	44	1.72
72C422-MI	72C422-BB	72C422-S6	1	43	1.69	47	1.84
72C428-MI	-	-	1	48	1.88	52	2.06
72C417-MI	72C417-BB	72C417-S6	1 1/4	52	2.06	57	2.25
72C422-MI	72C422-BB	72C422-S6	1 1/2	53	2.09	58	2.28
72C440-MI	-	-	1 1/2	57	2.25	62	2.44
72C447-MI	-	-	1 1/2	63	2.47	69	2.72
72C448-MI	72C448-BB	72C448-S6	2	64	2.50	71	2.78
72C456-MI	72C456-BB	72C456-S6	2	70	2.75	78	3.06
72C459-MI	-	-	2	78	3.09	87	3.44
72C464-MI	-	-	2 1/2	89	3.50	100	3.94
72C474-MI	-	-	3	97	3.81	106	4.19
72C478-MI	-	-	3	103	4.06	113	4.44

Style 73 | 6 Bolt Clamp



Part #			Hose ID	Hose Diameter Range OD			
Maleable Iron	Brass	316SS		Minimum		Maximum	
			in	mm	in	mm	in
73C668-MI	-	-	4	108	4.25	122	4.81
73C678-MI	-	-	4	124	4.88	135	5.31
73C696-MI	-	-	4	130	5.13	157	6.19
73C697-MI	-	-	6	175	6.88	183	7.19
73C700-MI	-	-	6	191	7.50	203	8.00

Crimp Ferrules

Thorburn permanent crimp sleeves are used in applications where a safe and reliable clamping method is preferred over band clamps or strapping. The sleeve provides a 360° uninterrupted compression around the hose and results in a durable attachment with no protrusions. The sleeves have smooth, beveled edges and are available in stainless steel or plated steel. Sleeves are chosen based on the length of the coupling barb and the actual hose outside diameter. As a general rule, the sleeve should be about 1/4" shorter than the hose barb. **Temperature Range:** -54°C (-65°F) to 150°C (300°F)

Style TF | Crimp Ferrules (Notched) Plated Steel - Sold with assembly only



Plated Steel	Nominal Hose Size		Sleeve ID		Sleeve Length	
	Part #	mm	in	mm	in	mm
TF-150-CP	25	1	38	1.50	58	2.29
TF-163-CP	25	1	41	1.63	58	2.29
TF-206-CP	38	1 1/2	52	2.06	60	2.36
TF-213-CP	38	1 1/2	54	2.13	60	2.36
TF-263-CP	52	2	67	2.63	71	2.79
TF-275-CP	52	2	70	2.75	71	2.79
TF-363-CP	75	3	92	3.63	100	3.94
TF-375-CP	75	3	95	3.75	100	3.94
TF-388-CP	75	3	99	3.88	100	3.94
TF-463-CP	100	4	118	4.63	106	4.19
TF-475-CP	100	4	121	4.75	106	4.19
TF-481-CP	100	4	122	4.81	106	4.19
TF-494-CP	100	4	125	4.94	106	4.19
TF-663-CP	150	6	168	6.63	144	5.67
TF-688-CP	150	6	175	6.88	144	5.67
TF-713-CP	150	6	181	7.13	144	5.67

Style TFS | Crimp Ferrules (Notched) 316 Stainless Steel - Sold with assembly only



Stainless Steel	Nominal Hose Size		Sleeve ID		Sleeve Length	
	Part #	mm	in	mm	in	mm
TFS-206-S6	38	1 1/2	52	2.06	60	2.36
TFS-213-S6	38	1 1/2	54	2.13	60	2.36
TFS-263-S6	52	2	67	2.63	71	2.79
TFS-275-S6	52	2	70	2.75	71	2.79
TFS-363-S6	75	3	92	3.63	100	3.94
TFS-375-S6	75	3	95	3.75	100	3.94
TFS-463-S6	100	4	118	4.63	106	4.19
TFS-481-S6	100	4	122	4.81	106	4.19

Crimp Ferrules

Thorburn permanent crimp ferrules are used in applications where a safe and reliable clamping method is preferred over band clamps or strapping. The sleeve provides a 360° uninterrupted compression around the hose and results in a durable attachment with no protrusions. The ferrules have smooth, beveled edges and are available in stainless steel or plated steel. Ferrules are chosen based on the length of the coupling barb and the actual hose outside diameter. As a general rule, the ferrule should be about 1/4" shorter than the hose barb. **Temperature Range:** -54°C (-65°F) to 150°C (300°F)

Style TSS | Crimp Short Ferrules Plated Steel (No notch & no ring insert) - Sold with assembly only



Plated Steel Part #	Nominal Hose Size		Sleeve ID		Sleeve Length	
	mm	in	mm	in	mm	in
TSS-038-CP	06	1/4	11	0.79	20	0.75
TSS-063-CP	10	3/8	17	0.98	25	1.00
TSS-088-CP	12	1/2	23	1.13	30	1.19
TSS-113-CP	20	3/4	29	1.13	30	1.19
TSS-138-CP	25	1	35	1.38	30	1.19
TSS-163-CP	25	1	41	1.63	30	1.19
TSS-175-CP	32	1 1/4	44	1.75	38	1.50
TSS-188-CP	32	1 1/4	48	1.88	38	1.50
TSS-200-CP	38	1 1/2	51	2.00	38	1.50
TSS-213-CP	51	2	54	2.13	51	2.00
TSS-263-CP	51	2	67	2.63	51	2.00
TSS-275-CP	52	2	70	2.75	51	2.00
TSS-363-CP	75	3	92	3.63	67	2.63
TSS-375-CP	75	3	95	3.75	67	2.63
TSS-388-CP	75	3	99	3.88	67	2.63
TSS-463-CP	100	4	118	4.63	87	3.44
TSS-475-CP	100	4	121	4.75	87	3.44
TSS-483-CP	100	4	123	4.83	87	3.44

Style TSSS | Crimp Short Ferrules 316 Stainless Steel (No notch & no ring insert) - Sold with assembly only



Plated Steel Part #	Nominal Hose Size		Sleeve ID		Sleeve Length	
	mm	in	mm	in	mm	in
TSSS-038-S6	06	1/4	11	0.79	20	0.75
TSSS-063-S6	10	3/8	17	0.98	25	1.00
TSSS-088-S6	12	1/2	23	1.13	30	1.19
TSSS-113-S6	20	3/4	29	1.13	30	1.19
TSSS-138-S6	25	1	35	1.38	30	1.19
TSSS-163-S6	25	1	41	1.63	30	1.19
TSSS-175-S6	32	1 1/4	44	1.75	38	1.50
TSSS-188-S6	32	1 1/4	48	1.88	38	1.50
TSSS-200-S6	38	1 1/2	51	2.00	38	1.50
TSSS-213-S6	51	2	54	2.13	51	2.00
TSSS-263-S6	51	2	67	2.63	51	2.00
TSSS-275-S6	52	2	70	2.75	51	2.00
TSSS-363-S6	75	3	92	3.63	67	2.63
TSSS-375-S6	75	3	95	3.75	67	2.63
TSSS-388-S6	75	3	99	3.88	67	2.63
TSSS-463-S6	100	4	118	4.63	87	3.44
TSSS-475-S6	100	4	121	4.75	87	3.44
TSSS-483-S6	100	4	123	4.83	87	3.44

Crimp Ferrules

Style TSL | Crimp Long Ferrules Plated Steel (No notch & no ring insert) - Sold with assembly only



Crimp Ferrule Sizes:

1/4" (6 mm), 3/8" (10 mm), 1/2" (12 mm), also available.

Plated Steel	Nominal Hose Size		Sleeve ID		Sleeve Length	
	Part #	mm	in	mm	in	mm
TSL-113-CP	20	3/4	29	1.13	54	2.13
TSL-138-CP	20	3/4	35	1.38	54	2.13
TSL-150-CP	25	1	38	1.50	57	2.31
TSL-163-CP	25	1	41	1.63	57	2.31
TSL-175-CP	25	1	44	1.75	57	2.31
TSL-213-CP	38	1 1/2	54	2.13	60	2.38
TSL-263-CP	52	2	67	2.63	70	2.75
TSL-275-CP	52	2	70	2.75	70	2.75
TSL-288-CP	52	2	73	2.88	70	2.75
TSL-313-CP	65	2 1/2	80	3.13	80	3.13
TSL-338-CP	65	2 1/2	86	3.38	80	3.13
TSL-363-CP	75	3	92	3.63	100	3.94
TSL-369-CP	75	3	91	3.61	100	3.94
TSL-375-CP	75	3	95	3.75	100	3.94
TSL-388-CP	75	3	99	3.88	100	3.94
TSL-400-CP	75	3	102	4.00	100	3.94
TSL-438-CP	100	4	111	4.38	106	4.19
TSL-463-CP	100	4	118	4.63	106	4.19
TSL-475-CP	100	4	121	4.75	106	4.19
TSL-483-CP	100	4	123	4.83	106	4.19
TSL-494-CP	100	4	125	4.94	106	4.19
TSL-650-CP	150	6	165	6.50	144	5.67
TSL-675-CP	150	6	171	6.75	144	5.67
TSL-688-CP	150	6	175	6.88	144	5.67
TSL-713-CP	150	6	181	7.13	144	5.67
TSL-850-CP	200	8	216	8.50	165	6.50
TSL-900-CP	200	8	229	9.00	165	6.50
TSL-1075-CP	250	10	273	10.75	165	6.50
TSL-1100-CP	250	10	279	11.00	165	6.50
TSL-1125-CP	250	10	286	11.25	165	6.50
TSL-1300-CP	300	12	330	13.00	229	9.00
TSL-1325-CP	300	12	337	13.25	229	9.00
TSL-1350-CP	300	12	343	13.50	229	9.00
TSL-1375-CP	300	12	349	13.75	229	9.00

Style TSLS | Crimp Long Ferrules 316 Stainless Steel (No notch & no ring insert) - Sold with assembly only



Crimp Ferrule Sizes:

1/4" (6 mm), 3/8" (10 mm), 1/2" (12 mm), also available.

Stainless Steel	Nominal Hose Size		Sleeve ID		Sleeve Length	
	Part #	mm	in	mm	in	mm
TSLS-125-S6	6	1/4	32	1.25	54	2.13
TSLS-138-S6	25	1	35	1.38	54	2.13
TSLS-150-S6	25	1	38	1.50	54	2.31
TSLS-163-S6	25	1	41	1.63	54	2.31
TSLS-175-S6	25	1	44	1.75	54	2.31
TSLS-188-S6	32	1 1/4	48	1.88	60	2.38
TSLS-213-S6	38	1 1/2	54	2.13	60	2.38
TSLS-225-S6	38	1 1/2	57	2.25	59	2.36
TSLS-263-S6	52	2	67	2.63	70	2.75
TSLS-275-S6	52	2	70	2.75	70	2.75
TSLS-313-S6	65	2 1/2	80	3.13	80	3.13
TSLS-369-S6	75	3	94	3.69	100	3.94
TSLS-375-S6	75	3	95	3.75	100	3.94
TSLS-388-S6	75	3	99	3.88	100	3.94
TSLS-483-S6	100	4	123	4.83	106	4.19
TSLS-494-S6	100	4	125	4.94	106	4.19

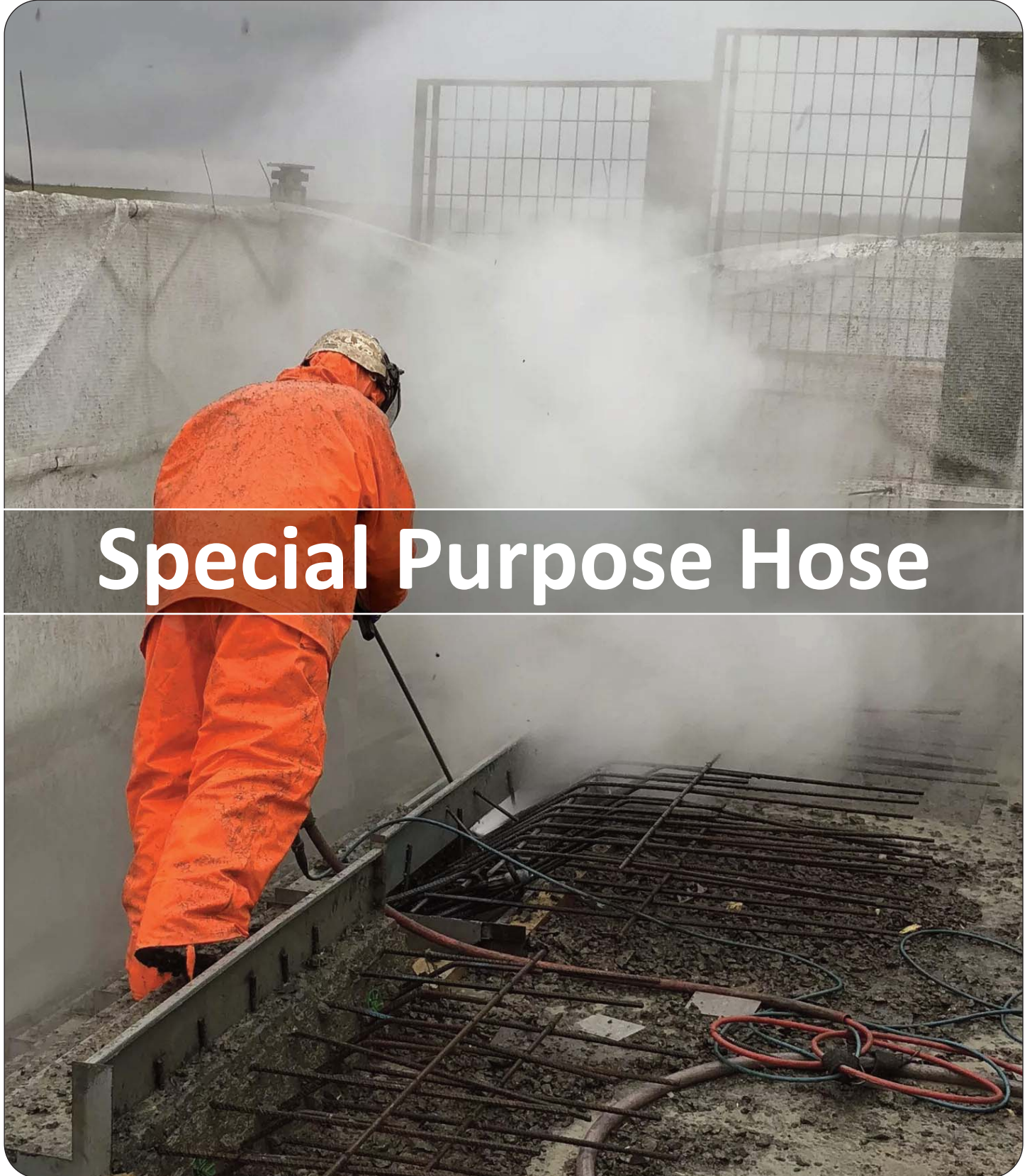

Special Purpose Hose

Thorburn Series PT Polyurethane Air Hose Assemblies

Thorburn Series PT Polyurethane coiled air hose is made from premium abrasion resistant polyurethane that easily outmatches rubber and nylon for wear resistance which comes in handy when working around unfinished or bare concrete floors. Highly kink resistant, the tubing also withstands twisting or crushing making it ideal for use in a range of situations from automotive shops to industrial work. The hose is lighter than equivalent rubber hoses making it easier to handle with less effort.

Features

- No swivel fittings required
- No hose spring guards required
- Standard tail lengths eliminate the need for additional whip hoses

Advantages

- Eliminates problems of kinking & abrasion
- Superior elasticity & recoil memory
- Impervious to heat & oil
- Smaller coil diameter saves storage and work space
- Low tension reduces operator fatigue
- Full flow reusable brass fittings
- Available as a Co-Axial assembly



Applications

- Pneumatic control & power lines
- Air tools & Instrumentation
- Assembly workstations
- Laboratories
- Electric assemblies
- Robotics

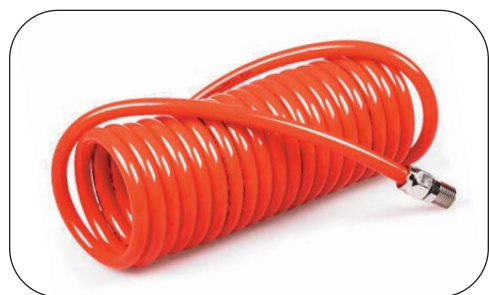

Factory Installed MPT Swivel in brass or 316 stainless steel

Standard Coil Hose Assemblies

Temperature: -54°C (-65°F) to 93°C (200°F)

Working Pressure: 8.3 bar (120 psi)

Note:

1. Heavier walled hose will better retain memory for vertical overhead installations.
2. working length = approx. 75% of total length.
3. Standard NPT fitting sizes apply to each hose size listed and installed on each end.



Safety Factor: 4:1

Thorburn Part #	Nominal Hose ID	MNPT Swivel	A		B		C		Total Length		Working Length		Wall Thickness
			in	mm	in	mm	in	mm	m	ft	m	ft	
PT4-4L10N	1/4	1/4	381	15	457	18	51	2	3.1	10	2.3	7.5	Normal
PT4-4L14N	1/4	1/4	381	15	457	18	51	2	4.3	14	3.2	10.5	Normal
PT4-4L18N	1/4	1/4	381	15	457	18	51	2	5.5	18	4.1	13.5	Normal
PT4-5L10N	5/16	1/4	381	15	457	18	64	2.5	3.1	10	2.3	7.5	Normal
PT4-5L14N	5/16	1/4	381	15	457	18	64	2.5	4.3	14	3.2	10.5	Normal
PT4-5L18N	5/16	1/4	381	15	457	18	64	2.5	5.5	18	4.1	13.5	Normal
PT6-6L10N	3/8	3/8	381	15	457	18	76	3	3.1	10	2.3	7.5	Normal
PT6-6L14N	3/8	3/8	381	15	457	18	76	3	4.3	14	3.2	10.5	Normal
PT6-6L18N	3/8	3/8	381	15	457	18	76	3	5.5	18	4.1	13.5	Normal
PT6-6L10H	3/8	3/8	381	15	457	18	76	3	3.1	10	2.3	7.5	Heavy
PT6-6L14H	3/8	3/8	381	15	457	18	76	3	4.3	14	3.2	10.5	Heavy
PT6-6L18H	3/8	3/8	381	15	457	18	76	3	5.5	18	4.1	13.5	Heavy
PT8-8L10H	1/2	1/2	381	15	457	18	102	4	3.1	10	2.3	7.5	Heavy
PT8-8L14H	1/2	1/2	381	15	457	18	102	4	4.3	14	3.2	10.5	Heavy
PT8-8L18H	1/2	1/2	381	15	457	18	102	4	5.5	18	4.1	13.5	Heavy

Note: N is used in the part number only when a Canadian CRN is required, when a code requirement must be met or material traceability is required. 4:1 Safety Factor required.

Thorburn Series PTC Polyurethane Co-Axial Air Hose Assemblies

Thorburn Co-Axial polyurethane air hose assemblies are designed to be used in conjunction with air-tool fabrication systems employing single point injection style lubricators. The 1/8" O.D. internal capillary line comes pre-filled with oil and has a capillary check valve attached to the end. Thorburn Co-Axial air hoses allow for motor lubrication of all sizes of pneumatic tools. Its full flow fitting system provides generous air flow rates which keep the toll lubricated and provides maximum torque and tool speed. Hoses come complete with male pipe fittings on each end.



Factory Installed MPT Swivel in brass or 316 stainless steel

Co-Axial Coil Hose Assemblies

Temperature: -54°C (-65°F) to 93°C (200°F)

Working Pressure: 8.3 bar (120 psi)



Capillary tube installed inside the air hose

Note:

A co-axial quick connect plug is available for connection to a co-axial style socket on the lubrication or stub hose assembly.



Safety Factor: 4:1

Thorburn Part #	Nominal Hose ID	MNPT Swivel	A		B		C		Total Length		Working Length		Wall Thickness
			mm	in	mm	in	mm	in	m	ft	m	ft	
PTC5-4L10N	1/4	1/4	5/16	381	15	457	18	64	3.1	10	2.3	7.5	Normal
PTC5-4L14N	1/4	1/4	5/16	381	15	457	18	64	4.3	14	3.2	10.5	Normal
PTC5-4L18N	1/4	1/4	5/16	381	15	457	18	64	5.5	18	4.1	13.5	Normal
PTC6-6L10N	5/16	3/8	3/8	381	15	457	18	76	3.1	10	2.3	7.5	Normal
PTC6-6L14N	5/16	3/8	3/8	381	15	457	18	76	4.3	14	3.2	10.5	Normal
PTC6-6L18N	5/16	3/8	3/8	381	15	457	18	76	5.5	18	4.1	13.5	Normal
PTC6-6L10H	3/8	3/8	3/8	381	15	457	18	76	3.1	10	2.3	7.5	Normal
PTC6-6L14H	3/8	3/8	3/8	381	15	457	18	76	4.3	14	3.2	10.5	Normal
PTC6-6L18H	3/8	3/8	3/8	381	15	457	18	76	5.5	18	4.1	13.5	Normal
PTC8-8L10H	3/8	1/2	1/2	381	15	457	18	102	3.1	10	2.3	7.5	Heavy
PTC8-8L14H	3/8	1/2	1/2	381	15	457	18	102	4.3	14	3.2	10.5	Heavy
PTC8-8L18H	3/8	1/2	1/2	381	15	457	18	102	5.5	18	4.1	13.5	Heavy

Note: N is used in the part number only when a Canadian CRN is required, when a code requirement must be met or material traceability is required. 4:1 Safety Factor required.

How To Order Thorburn Series PT/PTC Polyurethane Air Hose Assemblies

Hose Model	Hose Size	End Fitting Size	End Fitting Material	Hose Length (ft)	Series PTC Optional 1st End*	Series PTC Optional 2nd End*	Option
(N)PT	08	08	BB	14	3	6	TD212
(N)PT (N)PTC	04 = 1/4" 05 = 5/16" 06 = 3/8" 08 = 1/2"	04 = 1/4" 06 = 3/8" 08 = 1/2"	S6 = 316SS BB = Brass	10 = 10ft 14 = 14ft 18 = 18ft For metric lengths use (mm) at end of the part #	1 = 1/4" Co-Ax Quick Coupling Plug Adapter 2 = 3/8" Co-Ax Quick Coupling Plug Adapter 3 = 1/2" Co-Ax Quick Coupling Plug Adapter 4 = 1/4" Co-Ax Quick Coupling Socket Adapter 5 = 3/8" Co-Ax Quick Coupling Socket Adapter 6 = 1/2" Co-Ax Quick Coupling Socket Adapter	TD212 = Strata-Flow Blow Gun None = Leave Blank	* Optional Plug and Socket Adapters for Series PTC only

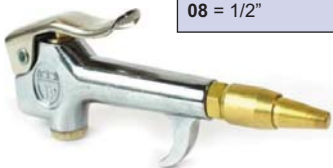

Optional: Thorburn Strata-Flow Blow Gun (Pg 165)

Thorburn Series TS Nylon Air Hose

Thorburn Series TS nylon coiled air hose combines flexibility and coil memory with resistance to instantaneous burst. Series TS hose assemblies are used wherever shop air is conducted from the main lines to portable air tools, air blow guns, air nozzles, etc. Complies with OSHA standards.

Features

- Self retracting and can repeatedly extend to 30 times its non-extended length and return to its original shape
- Rugged design that is extremely abrasion resistant
- Superior construction assures maximum life even in demanding conditions
- Chemical resistant and unaffected by lubricating oils, gasolines, solvents and most chemicals
- Light weight - 1/3 the weight of rubber hose
- Coil design saves on storage space
- High flow design maximizes air flow increasing efficiency and productivity
- Spring guards attached to prevent hose end failures

Standard Coil Hose Assemblies

Temperature: -40°C (-40°F) to 93°C (200°F)

Working Pressure: 16 bar (225 psi)

Note: Thorburn Self-Storing air hose assemblies do not snap back when released. It follows the user, retracting smoothly as the tool is returned toward the air source. It does not exert enough pull to move a light weight air tool.



Factory Installed MPT Swivel in brass or 316 stainless steel

Applications

- Automobile assembly lines
- Mechanical construction
- Robotic & automated systems
- Maintenance shops
- Automotive service stations
- Packaging industry

Safety Factor: 4:1

Thorburn Part #	Nominal Hose ID	Male NPT Swivel	Working Linear Length		Approx. Coil O.D.		Coil Overall Length	
	in	in	ft	m	in	mm	in	mm
TSCA-04-04-12	1/4	1/4	12	3.7	3 1/2	89	4 1/4	108
TSCA-06-04-12	3/8	1/4	12	3.7	6	152	4 1/4	108
TSCA-06-06-12	3/8	3/8	12	3.7	6	152	4 1/4	108
TSCA-08-08-12	1/2	1/2	12	3.7	8	203	4 1/4	108
TSCA-04-04-25	1/4	1/4	25	7.6	3 1/2	89	8 1/4	210
TSCA-06-04-25	3/8	1/4	25	7.6	6	152	8 1/4	210
TSCA-06-06-25	3/8	3/8	25	7.6	6	152	8 1/4	210
TSCA-08-08-25	1/2	1/2	25	7.6	8	203	8	203
TSCA-04-04-50	1/4	1/4	50	15	3 1/2	89	20	508
TSCA-06-06-50	3/8	3/8	50	15	6	152	17	432
TSCA-08-08-50	1/2	1/2	50	15	8	203	17	432

Note: N is used in the part number only when a Canadian CRN is required, when a code requirement must be met or material traceability is required. 4:1 Safety Factor required.

How To Order Thorburn Series TS Nylon 11 “Self-Store” Air Hose Assemblies

Hose Model	Hose Size	End Fitting Size	End Fitting Material	Hose Length (ft)	Option
(N)TSCA	08	08	BB	25	TD212
	04 = 1/4" 05 = 3/8" 08 = 1/2"	04 = 1/4" 05 = 5/16" 08 = 3/8"	S6 = 316SS BB = Brass	12 = 12ft 25 = 25ft 50 = 50ft For metric lengths use (mm) at end of the part #	TD212 = Strata-Flow Blow Gun None = Leave Blank

Thorburn Push-On / Lock-In Air Hose Assemblies

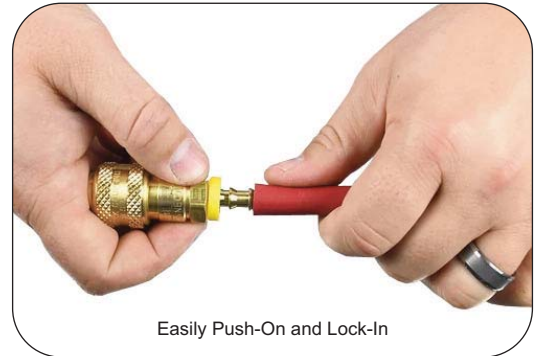
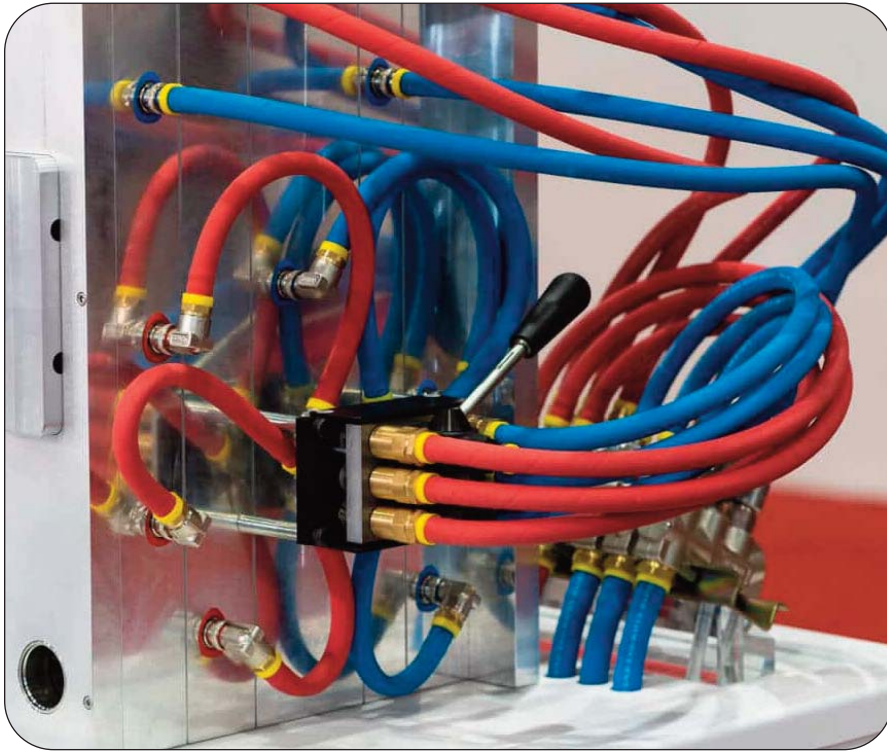

Thorburn Series (N)LOL

Push-On / Lock-In Hose



Thorburn Series (N)LOL: when used with our push-on lock-in couplings, simply by pushing the coupling into the hose, provides a fast, secure, hose assembly without clamps or ferrules (sleeves) or special tools. Thorburn's LOL hose assemblies are light weight and are pressure tested and can be supplied with a CRN and registered for systems that require B31.1 components. Push-on/Lock-In elastomers have a radiation resistance of 6×10^7 Roentgens.

Applications: Flexible connector used between instrument and instrument air supply or shop air systems, air lines on lumber sorters, newsprint handling equipment, machinery production lines, hydraulic case drains and general automotive service. Recommended for low pressure transfer of gasoline, fuel and lubricating oils, Not recommended for hydraulic impulse applications.

Safety Factor: 4:1

Thorburn Part #	Hose I.D.		Hose O.D.		Design Pressure		Weight	
	mm	in	mm	in	bar	PSI	kg/m	lb/ft
(N)LOL04	6.40	1/4	11.9	0.47	21	300	0.12	0.08
(N)LOL06	9.50	3/8	15.5	0.61	21	300	0.17	0.11
(N)LOL08	12.7	1/2	19.1	0.75	21	300	0.22	0.15
(N)LOL12	19.1	3/4	26.2	1.04	21	300	0.36	0.24

Note: Material code (Black Standard no code. For color codes, i.e. Grey Part Number: N4LOLGY).
Available Colors: Black (Standard), Grey (GY), Blue (BE), Green (GR), Red (RD) and Yellow (YW).
N is used in the part number only when a Canadian CRN is required, when a code requirement must be met or material traceability is required. 4:1 Safety Factor required.

Construction

Tube: Smooth, black oil-Resistant Nitrile-Butadiene blend (Type C)

Reinforcement: Braided, high tensile synthetic textile cord

Cover: Smooth, oil resistant, MSHA flame resistant Nitrile-Butadiene blend (Type C)

Cover Color: Black (Standard), Yellow (LOLY), Blue (LOLB), Red (LOLR), Grey, (LOLG), Green (LOLGN)

Operating Temperature:

-40°C (-40°F) to 100°C (212°F)

Typical Couplings:

Push-on/Lock-in reusable couplings only

LOL Push-On / Lock-In Standard Hose Couplings

Female JIC Swivel | Code - RFJX



Part Number		Nominal Hose I.D.		Fitting Size		Thread Size
Brass	316 Stainless Steel	Inch	mm	Inch	mm	
(N)4LOL-4RFJX-BB	N4LOL-4RFJX-S6	1/4	6	1/4	6	7/16 - 20
(N)6LOL-6RFJX-BB	N6LOL-6RFJX-S6	3/8	10	3/8	10	9/16 - 18
(N)8LOL-8RFJX-BB	N8LOL-8RFJX-S6	1/2	12	1/2	12	3/4 - 16
(N)12LOL-12RFJX-BB	N12LOL-12RFJX-S6	3/4	20	3/4	20	1-1/16 - 14

Tube Adapter | Code - RFT



Part Number		Nominal Hose I.D.		Fitting Size		Thread Size
Brass	316 Stainless Steel	Inch	mm	Inch	mm	
(N)4LOL-4RFT-BB	(N)4LOL-4RFT-S6	1/4	6	1/4	6	-
(N)6LOL-6RFT-BB	(N)6LOL-6RFT-S6	1/4	6	3/8	10	-
(N)6LOL-4RFT-BB	(N)6LOL-4RFT-S6	3/8	10	1/4	6	-
(N)8LOL-6RFT-BB	(N)8LOL-6RFT-S6	1/2	12	3/8	10	-
(N)8LOL-8RFT-BB	(N)8LOL-8RFT-S6	1/2	12	1/2	12	-
(N)12LOL-12RFT-BB	(N)12LOL-12RFT-S6	3/4	20	3/4	20	-

Male NPT | Code - RMP



Part Number		Nominal Hose I.D.		Fitting Size		Thread Size
Brass	316 Stainless Steel	Inch	mm	Inch	mm	
(N)4LOL-2RMP-BB	4LOL-2RMP-S6	1/4	6	1/8	3	1/8 - 27
(N)4LOL-4RMP-BB	4LOL-4RMP-S6	1/4	6	1/4	6	1/4 - 18
(N)4LOL-6RMP-BB	4LOL-6RMP-S6	1/4	6	3/8	10	3/8 - 18
(N)6LOL-4RMP-BB	6LOL-4RMP-S6	3/8	10	1/4	6	1/4 - 18
(N)6LOL-6RMP-BB	6LOL-6RMP-S6	3/8	10	3/8	10	3/8 - 18
(N)6LOL-8RMP-BB	6LOL-8RMP-S6	3/8	10	1/2	12	1/2 - 14
(N)8LOL-6RMP-BB	8LOL-6RMP-S6	1/2	12	3/8	10	3/8 - 18
(N)8LOL-8RMP-BB	8LOL-8RMP-S6	1/2	12	1/2	12	1/2 - 14
(N)12LOL-12RMP-BB	12LOL-12RMP-S6	3/4	20	3/4	20	3/4 - 14

LOL Push-On / Lock-In Standard Hose Couplings

Swagelok® Compatible Nut and Ferrule | Code - RFTA



Part Number		Nominal Hose I.D.		Fitting Size		Thread Size
Brass	316 Stainless Steel	Inch	mm	Inch	mm	
(N)4LOL-4RFTA-BB	4LOL-4RFTA-S6	1/4	6	1/4	6	-
(N)4LOL-6RFTA-BB	4LOL-6RFTA-S6	1/4	6	3/8	10	-
(N)6LOL-4RFTA-BB	6LOL-4RFTA-S6	3/8	10	1/4	6	-
(N)6LOL-6RFTA-BB	6LOL-6RFTA-S6	3/8	10	3/8	10	-
(N)8LOL-8RFTA-BB	8LOL-8RFTA-S6	1/2	12	1/2	12	-
(N)12LOL-12RFTA-BB	12LOL-12RFTA-S6	3/4	20	3/4	20	-

LOL Push-On / Lock-In Hose Accessories



Code - POLIT

Insertion Tool for Push-on/ Lock-In Fittings

- Cuts push-on style hose and inserts the fitting
- Built-in cutter slices through 1/4" - 3/4" ID reinforced push-on hose without fraying
- Clamp hose into tool's vice and apply light pressure on handle to drive in the fitting
- Has four 7/16" diameter mounting holes for bench mounting

How To Order Thorburn Push-On / Lock-In Hose Assemblies

Hose Model, Color & Size	Size	1st End Coupling	2nd End Coupling	1st End Fitting Material	2nd End Fitting Material	Hose Length (in)
LOLGR	08	RFJX	RFJX	S6	S6	600
Colors Black = Standard GY = Grey BE = Blue GR = Green RD = Red YW = Yellow	04 = 1/4" 06 = 3/8" 08 = 1/2" 12 = 3/4" 16 = 1"	RFJX = Female JIC swivel RFT = Tube adapter RFTA = Swagelok® compatible nut & ferrule RMP = Male NPT		BB = Brass S6 = 316SS XX = Other (Specify)		For metric lengths use (mm) at end of the part #

Thorburn Breathing Air Hose Assemblies



Thorburn Series (N)42TA

PVC Breathing Hose



Thorburn Series (N)42TA: Is a non-toxic, kink resistant, lightweight PVC textile reinforced hose that satisfies requirements of Type C respirators. (N) 42TA is designed to resist, permeation of noxious gases, solvent and silicone free hose. Our hose has been tested and satisfies the “off-gassing tests” as described in US MIL-H-2815F Sections 3.12.2 and 4.5.10., Mine Safety and Health Administration Regulations and passed the gasoline permeation tests as described in 30CFR Part 11.124-7. When coupled by Thorburn, (N)42TA satisfies the requirements for use in Type C Supplied Air Respirators. A type C respirator is for entry into and escape from atmospheres not immediately dangerous to life or health.

Applications: General Type C air supply lines, paint spray booths, indoor in plant air service, outdoor open-air service and to connect manifolds to masks, and Type C Supplied Air Respirators. Not for use as a diver's hose, a NEMO hose, or for use in sour gas applications.

Safety Factor: 4:1

Thorburn Part #	Hose I.D.		Hose O.D.		Design Pressure@70°F		Design Pressure@122°F		Weight	
	mm	in	mm	in	bar	PSI	bar	PSI	kg/m	lb/ft
(N)42TA04	6	1/4	16	0.62	17	250	10	150	0.12	0.08
(N)42TA06	10	3/8	18	0.69	17	250	10	150	0.21	0.14
(N)42TA08	12	1/2	21	0.84	17	250	10	150	0.30	0.20

Special Note: NIOSH only certifies complete breathing respirator systems, not hose assemblies alone
 N is used in the part number only when a Canadian CRN is required, when a code requirement must be met or material traceability is required. 4:1 Safety Factor required.

Construction

Tube: Smooth, clear, low permeation PVC compound, sanctioned by USFDA under CFR Title 21 Parts 170-199 (non-phthalate plasticizer)

Reinforcement: Multiple plies of high tensile yarn

Cover: Smooth Black PVC compound formulated with non-phthalate low temperature plasticizer Non-Toxic, U.V. and weather resistant

Operating Temperature:
 -26°C (-15°F) to 65°C (150°F)

Typical Hose End Couplings:
 Mighty crimp couplings

Thorburn Series (N)43TA/44TA

Premium Breathing Hose



Thorburn Series (N)43TA/ (N)44TA: Is a premium hose designed for carrying breathing air at high pressure from compressor to filter. FDA compatible white tube emits no odor or taste. Thorburn's (N)43TA/(N)44TA is crush resistant and the cover has excellent ozone resistance. Meets the standards of DIN EN 14593 & DIN EN 14594. Corrugated cover for sizes 3" and above for added flexibility.

Applications: Military, firefighting, industrial safety, medical and diving breathing systems.

Safety Factor: 4:1

Thorburn Part #	Hose I.D.		Hose O.D.		Design Pressure		Bend Radius		Weight	
	mm	in	mm	in	bar	PSI	mm	in	kg/m	lb/ft
(N)43TA/44TA04	6	1/4	15	0.6	14	200	65	2.6	0.25	0.17
(N)43TA/44TA06	10	3/8	19	0.75	14	200	75	3.0	0.30	0.20
(N)43TA/44TA08	12	1/2	25	1.0	14	200	100	3.9	0.35	0.24
(N)43TA/44TA12	20	3/4	31	1.2	14	200	115	4.5	0.50	0.34
(N)43TA/44TA16	25	1	38	1.5	14	200	150	5.9	0.60	0.40
(N)43TA/44TA20	32	1 1/4	48	1.9	14	200	190	7.5	0.80	0.54
(N)43TA/44TA24	38	1 1/2	56	2.2	14	200	230	9.1	1.00	0.67
(N)43TA/44TA32	50	2	67	2.7	14	200	300	11.8	1.50	1.00
(N)43TA/44TA48	80	3	89	3.5	10	150	305	12	2.78	1.87
(N)43TA/44TA64	100	4	114	4.5	10	150	406	16	3.79	2.55
(N)43TA/44TA80	125	5	170	6.7	10	150	508	20	7.57	5.09
(N)43TA/44TA96	150	6	185	7.3	10	150	635	25	9.75	6.55

N is used in the part number only when a Canadian CRN is required, when a code requirement must be met or material traceability is required. 4:1 Safety Factor required.

Construction

Tube: Smooth White Butyl (43TA)
Smooth White EPDM (44TA)

Other tubes, such as, UHMWPE are available upon request.

Reinforcement: High tensile wire helix embedded between layers of synthetic fabric

Cover: (1/4" - 1 1/2") Smooth Red, Ozone, weather, abrasion & UV resistant EPDM

(2" - 6") Corrugated Red, Ozone, weather, abrasion & UV resistant EPDM

Operating Temperature:

-40°C (-40°F) to 120°C (248°F)

Typical Hose End Couplings:

Male Pipe NPT

Female 37° JIC Swivel

Hose Stem Valved Coupler

Other fittings, such as, ANSI, PN Flanges and Sanitary Flanges are available upon request

Thorburn Breathing Air Standard Hose Couplings



How To Order Thorburn Breathing Air Hose Assemblies

Hose Model	Hose Size	1st End Coupling	2nd End Coupling	1st End Fitting Material	2nd End Fitting Material	Hose Length (in)
(N)43TA	08	01	03A	BB	BB	600
(N)42TA (N)43TA (N)44TA	04 = 1/4" 48 = 3" 06 = 3/8" 64 = 4" 08 = 1/2" 80 = 5" 12 = 3/4" 96 = 6" 16 = 1" 20 = 1 1/4" 24 = 1 1/2" 32 = 2"	01 = Male Pipe NPT 02 = Female 37° JIC Swivel 03 = Coupling Stem Complete Set with... A = 1/4" Body B = 3/8" Body YY = Other (Specify)	BB = Brass S6 = 316SS XX = Other (Specify)			For metric lengths use (mm) at end of the part #

N is used in the part number only when a Canadian CRN is required, when a code requirement must be met or material traceability is required. 4:1 Safety Factor required.

Thorburn Rubber Pressure Washer Assemblies



Thorburn Series (N)TPWBLU

Standard Pressure Washer Hose



Thorburn Series (N)TPWBLU: Is a light weight easy to handle , 3000 psi high pressure washer hose designed for use with cold or hot water heavy duty pressure washing applications. The cover is constructed to be non-marking. Typical assembly lengths are 15M (50'), 23M (75'), 30M (100'), 60M (195'). Ergonomic bend restrictors are included in each assembly. All Thorburn waterblast hose assemblies are factory pressure tested to 1.5 times design pressure.

Applications: Clean up at poultry plants, dairies, off road equipment, paper mills, construction sites , homes and patio cleaning. Can be used with mild detergents

Safety Factor: 3:1

Thorburn Part #	Hose I.D.		Hose O.D.		Design Pressure		Bend Radius		Weight	
	mm	in	mm	in	bar	PSI	mm	in	kg/m	lb/ft
(N)TPWBLU04	6	1/4	13	0.50	207	3000	102	4	0.19	0.13
(N)TPWBLU06	10	3/8	16	0.63	207	3000	127	5	0.27	0.18
(N)TPWBLU08	12	1/2	20	0.79	207	3000	178	7	0.37	0.25

Warning: Not recommended for steam service

N is used in the part number only when a Canadian CRN is required, when a code requirement must be met or material traceability is required. 4:1 Safety Factor required.

Construction

Tube: Black synthetic Smooth, oil, heat and detergent resistant Buna N blend

Reinforcement: High tensile braided, brass plated steel wire

Cover: Blue non-marking, abrasion, ozone, weather and heat resistant synthetic rubber blend Neoprene

Operating Temperature:

-40°C to 122°C (-40°F to 250°F)

Typical Hose End Couplings: (See Page 121)

Thorburn Rubber Pressure Washer Standard Hose Couplings



Code MP
Rigid Male NPT
Crimp Couplings



Code MPX
Male NPT Swivel
Crimp Couplings



Code FJX
37° Female Swivel
Crimp Couplings



Code KX
Karcher Swivel
Crimp Couplings



Codes
QNF Female Non-Valved Nipple/Plug
QNFV Female Valved Nipple/Plug

Comes Standard with Buna N sleeves



Codes
QCF Female Non-Valved Coupler (Socket)
QCFV Female Valved Coupler (Socket)

Comes Standard with Buna N sleeves

How To Order Thorburn Pressure Washer Hose Assemblies

Hose Model	Hose Size	1st End Coupling	2nd End Coupling	1st End Fitting Material	2nd End Fitting Material	Hose Length (in)
TPWBLU	08	MPX	FJX	S6	S6	600
	04 = 1/4" 06 = 3/8" 08 = 1/2"	MP = Rigid Male NPT Crimp Couplings MPX = Male NPT Swivel Crimp Couplings FJX = 37° Female Swivel Crimp Couplings KX = Karcher Swivel Crimp Couplings QNF Female Non-Valved Nipple/Plug QNFV Female Valved Nipple/Plug QCF Female Non-Valved Coupler/Socket QCFV Female Valved Coupler/Socket		CP = Carbon Steel (Plated) S6 = 316SS XX = Other (Specify)		For metric lengths use (mm) at end of the part #

Thorburn Rubber Water Blast Assemblies



Water blasting is a form of high-pressure cleaning that relies entirely on the power of water. It can be used to strip paint and clean dirty surfaces quickly without resorting to abrasive sandblasting media.

It is faster to implement than sandblasting and there is minimal clean-up, with no abrasives to collect and dispose of. Water blasting does not use any harmful chemicals or hazardous substances, which makes it completely safe for both surfaces and the environment. Water blasting is an ideal method for surface restoration, dirt removal, adherent paint removal and surface preparation.

Thorburn Series (N)23TW

High Pressure Water Blast Hose



Thorburn Series (N)23TW: Is a heavy-duty high pressure 10,000 psi (670 Bar) water-blast hose. Since water is used, rather than chemicals or abrasives, water blasting is an environmentally friendly method of cleaning and surface preparation. All Thorburn Waterblast hose assemblies are factory pressure tested to 1.5 times design pressure.

Applications: Hydro-demolition (concrete breaking using high pressure water instead of a jackhammer) used for cleanings tanks, heat exchangers and pipes, marine growth on ships and piers.

Safety Factor: 2.5:1

Thorburn Part #	Hose I.D.		Hose O.D.		Design Pressure		Bend Radius		Weight	
	mm	in	mm	in	bar	PSI	mm	in	kg/m	lb/ft
(N)23TW04	6	1/4	21	0.81	689	10,000	127	5.0	0.82	0.55
(N)23TW06	10	3/8	25	0.97	689	10,000	152	6.0	0.89	0.60
(N)23TW08	12	1/2	28	1.09	689	10,000	203	8.0	1.71	1.15
(N)23TW12	20	3/4	32	1.26	689	10,000	279	11.0	1.92	1.29
(N)23TW16	25	1	39	1.52	689	10,000	356	14.0	2.38	1.60

Warning: For waterblast purposes only
N is used in the part number only when a Canadian CRN is required, when a code requirement must be met or material traceability is required. 4:1 Safety Factor required

Construction

Tube: Smooth black, Seamless, heat- and oil-resistant synthetic rubber

Reinforcement: Four or six layers of alternated, spiraled, high tensile plated steel wire

Cover: black, ozone and weather Synthetic abrasion, oil, fuel and weather resistant rubber

Operating Temperature:
 -40°C to 100°C (-40°F to 212°F)

Typical Hose End Couplings: Factory assembled Thorburn special crimp type hose couplings
 (See Page 124)

Thorburn Series (N)23TWX

Ultra High Pressure Water Blast Hose



Thorburn Series (N)23TWX: Is a 15,000 psi (1034 Bar) water blast hose that is often found in hydro-demolition (concrete breaking using water instead of a jackhammer). It is also used for cleaning large tanks, heat exchangers and pipes, as well as for removing marine growth on ships and piers. Since only water is used in the work rather than chemicals or abrasives, water jetting is an environmentally friendly method of cleaning and surface preparation.

Applications: Hydro-demolition (concrete breaking using high pressure water instead of a jackhammer) used for cleanings tanks, heat exchangers and pipes, marine growth on ships and piers.

Safety Factor: 2.5:1

Thorburn Part #	Hose I.D.		Hose O.D.		Design Pressure		Bend Radius		Weight	
	mm	in	mm	in	bar	PSI	mm	in	kg/m	lb/ft
(N)23TWX04	6	1/4	20	0.79	1379	20000	127	5	0.82	0.55
(N)23TWX06	10	3/8	21	0.81	1379	20000	152	6	0.90	0.60
(N)23TWX08	12	1/2	30	1.16	1379	20000	203	8	1.72	1.15
(N)23TWX12	20	3/4	35	1.38	1379	20000	300	12	2.53	1.70

Warning: For waterblast purposes only. It is not recommended to use NPT threads greater than 10,000 PSI (69 bar) service.
N is used in the part number only when a Canadian CRN is required, when a code requirement must be met or material traceability is required. 4:1 safety factor is required. The design pressure would be 10,000 PSI (389 bar) instead of 15,000 PSI (1034 bar).

Construction

Tube: Oil and water resistant synthetic rubber

Reinforcement: Four or six high tensile steel spirals or four high tensile steel spirals with one steel braid.

Cover: Oil, water and ozone resistant synthetic rubber

Operating Temperature:
 -40°C to 100°C (-40°F to 212°F)

Typical Hose End Couplings: Factory assembled Thorburn crimp type hose couplings
 (See Page 124)

Thorburn Rubber Water Blast Standard Hose Couplings

Style 1 | BSPP Female 60° With O-Ring



Thorburn Part #	Hose ID		Thread Size
	in	mm	in
23TW-04-04-FBSPP-XX*	1/4	6	1/4-19
23TW-06-06-FBSPP-XX*	3/8	10	3/8-19
23TW-08-08-FBSPP-XX*	1/2	12	1/2-14
23TW-12-12-FBSPP-XX*	3/4	20	3/4-14

*XX = Materials: 316 Stainless Steel (Code S6), Carbon Steel (Code CS) **Note:** Waterblast inserts are made using a special steel in order to enhance performance and reliability. Couplings are sold assembled to hose.

Style 2 | NPT Male 60°



Thorburn Part #	Hose ID		Thread Size
	in	mm	in
23TW-04-04-MNPT-XX*	1/4	6	1/4-18
23TW-06-06-MNPT-XX*	3/8	10	3/8-18
23TW-08-08-MNPT-XX*	1/2	12	1/2-14
23TW-12-12-MNPT-XX*	3/4	20	3/4-14
23TW-16-16-MNPT-XX*	1	25	1-11

*XX = Materials: 316 Stainless Steel (Code S6), Carbon Steel (Code CS) **Note:** Waterblast inserts are made using a special steel in order to enhance performance and reliability. Couplings are sold assembled to hose.

Style 3 | BSPT Male 60°



Thorburn Part #	Hose ID		Thread Size
	in	mm	in
23TW-08-08-MBSPT-XX*	1/2	12	1/2-14
23TW-12-12-MBSPT-XX*	3/4	20	3/4-14
23TW-16-16-MBSPT-XX*	1	25	1-11

*XX = Materials: 316 Stainless Steel (Code S6), Carbon Steel (Code CS) **Note:** Waterblast inserts are made using a special steel in order to enhance performance and reliability. Couplings are sold assembled to hose.

Style 4 | Female 24° Cone (Metric) With O-Ring - Heavy DIN 3865 DKOS Slip On Nut with Relief Nut



Thorburn Part #	Hose ID		Thread Size
	in	mm	in
23TW-08-M24X1.5-FDHX-XX*	1/2	12	M24X1.5
23TW-12-M30X2-FDHX-XX*	3/4	20	M30X2
23TW-12-M36X2-FDHX-XX*	3/4	20	M36X2
23TW-12-M36X2-FDHX-XX*	3/4	20	M36X2
23TW-16-M36X2-FDHX-XX*	1	20	M36X2
23TW-16-M42X2-FDHX-XX*	1	25	M42X2

*XX = Materials: 316 Stainless Steel (Code S6), Carbon Steel (Code CS) **Note:** Waterblast inserts are made using a special steel in order to enhance performance and reliability. Couplings are sold assembled to hose.

Thorburn Rubber Water Blast Standard Hose Couplings

Standard Coupling Styles - Codes and Sizes																
Hose Couplings	Style #1				Style #2					Style #3			Style #4			
	BSPF Female 60° With O-Ring				NPT Male 60°					BSPT Male 60°			Female 24° Cone (Metric) with O-Ring			
Thread Codes	A	B	C	D	E	F	G	H	I	J	K	L	M	N	O	P
Thread Size	1/4 - 19	3/8 - 19	1/2 - 14	3/4 - 14	1/4 - 18	3/8 - 18	1/2 - 14	3/4 - 14	1 - 11	1/2 - 14	3/4 - 14	1 - 11	M24 X 1.5	M30 X 2	M36 X 2	M42 X 2
Hose Model																
23TW04	✓				✓											
23TW06		✓				✓										
23TW08			✓				✓			✓			✓			
23TW12				✓				✓			✓			✓	✓	
23TW16									✓			✓			✓	✓
23TWX04	✓				✓											
23TWX06		✓				✓										
23TWX08			✓				✓			✓			✓			
23TWX12				✓				✓			✓			✓	✓	

Other sizes and materials available upon request

How To Order Thorburn Water Blast Hose Assemblies

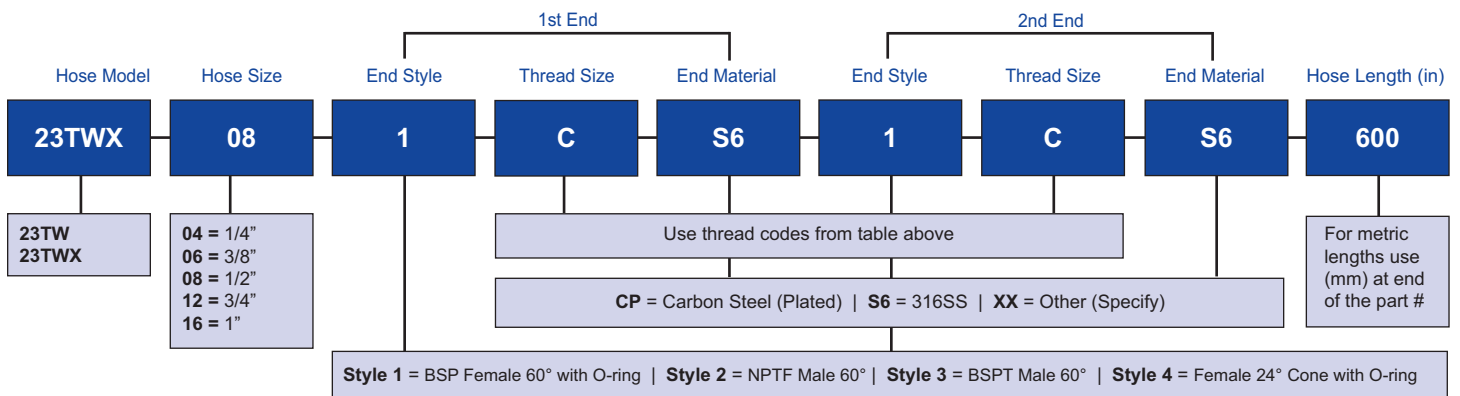

Thorburn Hydro-Demolition Hose Assemblies



Applications

Waterblast: Heat exchanger tube cleaning, surface preparation (concrete removal, surface cleaning of buildings, paint removal, ultra high-pressure waterjet cutting and hydro and hydro demolition cutting (of armored concrete, pipelines, paper or steel), heat exchanger tube cleaning.

Hydraulics: Hydraulic tools (instrumentation packages for gauges, control of service equipment, hydraulic jacks, hydraulic tools (instrumentation packages for gauges, hydro-forming pressure test equipment (valves, tooling and control panels), hydraulic tools, instrumentation packages for gauges, control of service equipment.

Hydraulic Hose: Autofrettage, hydroforming, hydraulic assembly presses, dismantling of ball bearings and torsion-free fastening of screwed connections (bolt-tensioning).

Oil and Gas: Grease injection, methanol service (oil rigs, distribution panels, umbilical's), jumper/subsea well control, control of subsea hydraulic components, nitrogen service Gaseous media handling offshore hose bundles, methanol service on platforms, chemical injections at the wellbore, hydraulic component control, hydrogen fueling systems.

Thorburn Series (N)11TWB

Ultra High Pressure Hose



Thorburn Series (N)11TWB: Is designed for high pressure water blast service. This versatile hose assembly is lighter, more flexible and easier to handle compared to rubber waterblast hose assemblies. The hose has low permeation, strong resistance to hydrolysis and microbes, low volumetric expansion at maximum working pressures and is kink resistant. Thorburn's (N)11TWB Compound formulation provides excellent resistance to solvents and chemicals.

Safety Factor: 2.5:1

Thorburn Part #	Hose I.D.		Hose O.D.		Design Pressure		Bend Radius		Weight	
	mm	in	mm	in	bar	PSI	mm	in	kg/m	lb/ft
(N)11TWB02	3	1/8	7	0.28	1000	14504	60	2.4	0.08	0.13
(N)11TWB03	4	3/16	8	0.31	1200	17405	75	3.0	0.07	0.11
(N)11TWB035	5	7/32	9	0.35	1120	16244	95	3.7	0.08	0.13
(N)11TWB04	6	1/4	13	0.51	1120	16244	95	3.7	0.30	0.20
(N)11TWB05	8	5/16	15	0.59	1040	15084	110	4.3	0.35	0.24
(N)11TWB06	10	3/8	17	0.67	800	11603	125	4.9	0.47	0.32
(N)11TWB08	12	1/2	21	0.83	800	11603	150	5.9	0.69	0.46
(N)11TWB12	20	13/16	29	1.14	560	8122	220	8.7	1.05	0.71
(N)11TWB16	25	1	33	1.29	480	6962	280	11.0	1.20	0.81

N is used in the part number only when a Canadian CRN is required, when a code requirement must be met or material traceability is required. 4:1 Safety Factor required.

Construction

Tube: Polyamid PA / Nylon 11/12

Reinforcement: Multiple layers of high tensile steel spiraled wire

Cover: Black, Polyamid PA / Nylon 11/12

Operating Temperature:

-40°C to 60°C (-40°F to 140°F)

Typical Hose End Couplings:

Thorburn factory installed hydro-demolition couplings
(See Pages 129 - 131)

Thorburn Series (N)44TWB

Ultra High Pressure Hose



Thorburn Series (N)44TWB: Is an ultra-high pressure hose that is light weight and easy to maneuver. The hose is designed for ultra-high pressure fluid transmission of water, oil, solvents and chemicals. It is impervious to sea water and is highly ozone resistant, has a low permeation rate, has strong resistance to hydrolysis and microbes, and has a low volumetric expansion at maximum working pressures. Thorburn (N)44TWB spiral braided construction makes it is kink resistant, has a small bend radius, has minimal pressure drop, has high flow volumes, and has a long flex impulse service life.

Safety Factor: 2.5:1

Thorburn Part #	Hose I.D.		Hose O.D.		Design Pressure		Bend Radius		Weight	
	mm	in	mm	in	bar	PSI	mm	in	kg/m	lb/ft
(N)44TWB02	3	1/8	8	0.31	2308	33475	110	4.3	0.14	0.09
(N)44TWB03	4	3/16	10	0.39	2160	31328	130	5.1	0.23	0.15
(N)44TWB035	5	7/32	11	0.43	1800	26107	150	5.9	0.26	0.17
(N)44TWB04	6	1/4	13	0.51	1520	22046	180	7.1	0.30	0.20
(N)44TWB05	8	5/16	15	0.59	1520	22046	200	7.9	0.39	0.26
(N)44TWB06	10	3/8	18	0.71	1520	22046	200	7.9	0.69	0.46
(N)44TWB08	13	1/2	22	0.87	1400	20305	200	7.9	0.88	0.59
(N)44TWB12	20	13/16	30	1.18	1020	14794	250	9.8	0.35	0.24

N is used in the part number only when a Canadian CRN is required, when a code requirement must be met or material traceability is required. 4:1 Safety Factor required.

Construction

Tube: Polyamide PA / Nylon 11/12 Excellent chemical resistance to oil, chemicals, detergents , solvents

Reinforcement: Eight layers of high tensile plated steel maximum pressure resistance, tight minimum bend radius

Cover: Black Polyamide PA / Nylon 11/12 Abrasive resistant

Operating Temperature: -30°C (-22°F) to 80°C (176°F)

Typical Hose End Couplings:

Thorburn factory installed hydro-demolition couplings (See Pages 129 - 131)

Thorburn Series (N)66TWB

Ultra High Pressure Hose



Thorburn Series (N)66TWB: Is an ultra-high pressure hose that is light weight, easy to maneuver and is available in very long lengths. The hose is designed for ultra-high pressure fluid transmission of water, oil, solvents and chemicals. It is impervious to sea water and is highly ozone resistant, has a low permeation rate, has strong resistance to hydrolysis and microbes, and has a low volumetric expansion at maximum working pressures. Thorburn's (N)66TWB spiral braided construction makes it is kink resistant, has a small bend radius, has minimal pressure drop, has high flow volumes, and has a long flex impulse service life.

Safety Factor: 2.5:1

Thorburn Part #	Hose I.D.		Hose O.D.		Design Pressure		Bend Radius		Weight	
	mm	in	mm	in	bar	PSI	mm	in	kg/m	lb/ft
(N)66TWB03	4	3/16	12	0.47	2800	40611	175	6.9	0.37	0.25
(N)66TWB035	5	7/32	14	0.55	2800	40611	220	8.7	0.52	0.35
(N)66TWB05	8	5/16	18	0.71	2500	36259	250	9.8	0.83	0.56
(N)66TWB06	10	3/8	20	0.79	1920	27847	250	9.8	1.00	0.67
(N)66TWB08	13	1/2	23	0.91	1800	26107	300	11.8	1.16	0.78
(N)66TWB12	20	13/16	31	1.22	1400	20305	350	13.7	1.92	1.29

N is used in the part number only when a Canadian CRN is required, when a code requirement must be met or material traceability is required. 4:1 Safety Factor required.

Construction

Tube: Polyamide PA / Nylon 11/12 Excellent chemical resistance to oil, chemicals, detergents , solvents

Reinforcement: Eight layers of high tensile plated steel maximum pressure resistance, tight minimum bend radius

Cover: Black Polyamide PA / Nylon 11/12 Abrasive resistant

Operating Temperature: -30°C (-22°F) to 80°C (176°F)

Typical Hose End Couplings:

Thorburn factory installed hydro-demolition couplings (See Pages 129 - 131)

Thorburn Series (N)88TWB

Ultra High Pressure Hose



Thorburn Series (N)88TWB: Is an ultra-high pressure hose that is light weight, easy to maneuver and is available in very long lengths. The hose is designed for ultra-high pressure fluid transmission of water, oil, solvents and chemicals. It is impervious to sea water and is highly ozone resistant, has a low permeation rate, has strong resistance to hydrolysis and microbes, and has a low volumetric expansion at maximum working pressures. Thorburn's (N)88TWB spiral braided construction makes it is kink resistant, has a small bend radius, has minimal pressure drop, has high flow volumes, and has a long flex impulse service life.

Safety Factor: 2.5:1

Thorburn Part #	Hose I.D.		Hose O.D.		Design Pressure		Bend Radius		Weight	
	mm	in	mm	in	bar	PSI	mm	in	kg/m	lb/ft
(N)88TWB03	4	3/16	14	0.55	3200	46412	175	6.9	0.58	0.39
(N)88TWB05	8	5/16	20	0.79	2760	40030	300	11.8	1.12	0.75

N is used in the part number only when a Canadian CRN is required, when a code requirement must be met or material traceability is required. 4:1 Safety Factor required.

Construction

Tube: Polyamide PA / Nylon 11/12 Excellent chemical resistance to oil, chemicals, detergents, solvents

Reinforcement: Eight layers of high tensile plated steel maximum pressure resistance, tight minimum bend radius

Cover: Black Polyamide PA / Nylon 11/12 Abrasive resistant

Operating Temperature:
-30°C (-22°F) to 80°C (176°F)

Typical Hose End Couplings:

Thorburn factory installed hydro-demolition couplings
(See Pages 129 - 131)

Thorburn Hydro-Demolition Hose Couplings



Cone and threaded tube high pressure fittings use a metal-to-metal seal with an interference fit. They do not require an o-ring. In this design, a tube is forced into a coned surface. A collar is threaded onto the tube and a gland nut holds the sleeve and tubing against the coned surface. Cone and threaded tube fittings ensures reliable medium and high pressure connection performance.

Thorburn Hydro-Demolition Standard Hose Couplings

**Style 5 | Male 58° Cone 50,000 PSI
(3447 bar) 2.5:1 Safety Factor**



Thorburn Part #	Hose ID		Thread Size
	in	mm	in
XX-02-04-MHP	1/8	3	1/4-28 UNF LH
XX-03-04-MHP	3/16	4	1/4-28 UNF LH
XX-04-09-MHP	1/4	6	9/16-18 UNF LH
XX-035-04-MHP	7/32	5	1/4-28 UNF LH
XX-04-06-MHP	1/4	6	3/8-24 UNF LH
XX-05-09-MHP	5/16	8	9/16-18 UNF LH
XX-06-09-MHP*	3/8	10	9/16-18 UNF LH
XX-08-09-MHP*	1/2	13	9/16-18 UNF LH
XX-08-12-MHP*	1/2	13	3/4-16 UNF LH
XX-12-16-MHP*	3/4	20	1-14 UNF LH
XX-03-06-MHP*	3/16	4	3/8-24 UNF LH
XX-035-06-MHP*	7/32	5	3/8-24 UNF LH
XX-035-09-MHP*	7/32	5	9/16-18 UNF LH
XX-05-06-MHP*	5/16	8	3/8-24 UNF LH
XX-05-12-MHP*	5/16	8	3/4-16 UNF LH

*XX = Place Hose Code - (N)11TWB, (N)44TWB, (N)66TWB, (N)88TWB

**Style 6 | Female 58° Cone 50,000 PSI
(3447 bar) 2.5:1 Safety Factor**



Thorburn Part #	Hose ID		Thread Size
	in	mm	in
XX-03-09-FHP	3/16	4	9/16-18 UNF
XX-035-09-FHP	7/32	5	9/16-18 UNF
XX-04-09-FHP	1/4	6	9/16-18 UNF
XX-05-12-FHP	5/16	8	3/4-16 UNF
XX-06-12-FHP	3/8	10	3/4-16 UNF
XX-08-16-FHP	1/2	13	1-12 UNF
XX-12-21-FHP	3/4	20	1 5/16-12 UNF
XX-02-04-FHP	1/8	3	1/4-28 UNF
XX-05-14-FHP	5/16	8	7/8-14 UNF

*XX = Place Hose Code - (N)11TWB, (N)44TWB, (N)66TWB, (N)88TWB

Thorburn Hydro-Demolition Standard Hose Couplings

**Style 7 | BSPT Male 10,000 PSI (689 bar)
2.5:1 Safety Factor**



Thorburn Part #	Hose ID		Thread Size
	in	mm	in
XX-03-02-MBSPT	3/16	4	1/8-24
XX-035-02-MBSPT	7/32	5	1/8-24
XX-035-04-MBSPT	7/32	5	1/4-19
XX-04-02-MBSPT	1/4	6	1/8-24
XX-04-04-MBSPT	1/4	6	1/4-19
XX-05-04-MBSPT	5/16	8	1/4-19
XX-05-06-MBSPT	5/16	8	3/8-19
XX-08-08-MBSPT	1/2	13	1/2-14

*XX = Place Hose Code - (N)11TWB, (N)44TWB, (N)66TWB, (N)88TWB

**Style 8 | Female BSPP 24° Cone
15,000 PSI (1034 bar)
2.5:1 Safety Factor**



Thorburn Part #	Hose ID		Thread Size
	in	mm	in
XX-03-04-BSPPF	3/16	4	1/4-19
XX-035-04-BSPPF	7/32	5	1/4-19
XX-04-04-BSPPF	1/4	6	1/4-19
XX-05-06-BSPPF	5/16	8	3/8-19
XX-06-08-BSPPF	3/8	10	1/2-14
XX-05-04-BSPPF	5/16	8	1/4-19

*XX = Place Hose Code - (N)11TWB, (N)44TWB, (N)66TWB, (N)88TWB

Thorburn Hydro-Demolition Standard Hose Couplings

Style 9 | Male NPT 15,000 PSI (1034 bar)
2.5:1 Safety Factor for sizes 1/8"-1/2"
10,000 PSI (689 bar) for Sizes 3/4"-1"



Thorburn Part #	Hose ID		Thread Size
	in	mm	in
XX-02-01-MNPT	1/8	3	1/16-27 NPT
XX-03-01-MNPT	3/16	4	1/16-27 NPT
XX-03-02-MNPT	3/16	4	1/8-27 NPT
XX-03-04-MNPT	3/16	4	1/4-18 NPT
XX-035-02-MNPT	7/32	5	1/8-27 NPT
XX-035-04-MNPT	7/32	5	1/4-18 NPT
XX-04-02-MNPT	1/4	6	1/8-27 NPT
XX-04-04-MNPT	1/4	6	1/4-18 NPT
XX-04-06-MNPT	1/4	6	3/8-18 NPT
XX-06-06-MNPT	3/8	10	3/8-18 NPT
XX-08-08-MNPT	1/2	13	1/2-14 NPT
XX-12-12-MNPT	3/4	20	3/4-14 NPT
XX-12-16-MNPT	3/4	20	1-11 1/2 NPT
XX-16-16-MNPT	1	25	1-11 1/2 NPT
XX-05-04-MNPT	5/16	8	1/4-18 NPT
XX-05-10-MNPT	5/16	8	3/8-18 NPT

*XX = Place Hose Code - (N)11TWB, (N)44TWB, (N)66TWB, (N)88TWB

Style 10 | Female Metric 24° Cone
15,000 PSI (1034 bar)
2.5:1 Safety Factor



Thorburn Part #	Hose ID		Thread Size
	in	mm	in
XX-16-16-FDHX	1	25	M42X2

*XX = Place Hose Code - (N)11TWB, (N)44TWB, (N)66TWB, (N)88TWB



Thorburn Hydro-Demolition Standard Hose Couplings

Standard Coupling Styles - Codes and Sizes																												
Pressure	High Pressure											Medium Pressure						Low Pressure										
Coupling Style	# 5 Male HP					# 6 Female HP						# 7 Male				# 8 Female		# 9 Male					# 10					
Thread Codes	A	B	C	D	E	F	G	H	I	J	K	L	M	N	O	P	Q	R	S	T	U	V	W	X	Y	Z		
Thread Size	1/4 X 28 UNF LH	3/8 X 24 UNF LH	9/16 X 18 UNF LH	3/4 X 16 UNF LH	1 X 14 UNF LH	1/4 X 28 UNF	9/16 X 18 UNF	3/4 X 16 UNF	7/8 X 14 UNF	1 X 12 UNF	1 5/16 X 12 UNF	1/8 X 24 BSPT	1/4 X 19 BSPT	3/8 X 19 BSPT	1/2 X 14 BSPT	1/4-19 BSPP	3/8-19 BSPP	1/2-14 BSPP	1/16 X 27 NPT	1/8 X 27 NPT	1/4 X 18 NPT	3/8 X 18 NPT	1/2 X 14 NPT	3/4 X 14 NPT	1 X 11 1/2 NPT	M42 X 2		
Hose Codes																												
88TWB03	✓	✓					✓																					
88TWB05		✓	✓						✓																			
66TWB03	✓	✓					✓																					
66TWB035	✓	✓	✓				✓									✓												
66TWB05		✓	✓	✓				✓	✓								✓											
66TWB06			✓					✓										✓										
66TWB08			✓	✓						✓													✓					
66TWB12											✓																	
44TWB02	✓						✓																					
44TWB03	✓	✓					✓																					
44TWB035	✓	✓	✓				✓						✓				✓					✓						
44TWB04		✓					✓															✓						
44TWB05			✓					✓									✓						✓					
44TWB06			✓					✓									✓											
44TWB08			✓	✓						✓													✓					
44TWB12					✓						✓														✓	✓		
11TWB02																			✓									
11TWB03	✓						✓					✓				✓			✓	✓	✓							
11TWB035							✓					✓	✓			✓			✓	✓	✓							
11TWB04			✓				✓					✓	✓			✓			✓	✓	✓							
11TWB05													✓	✓			✓		✓	✓	✓							
11TWB06								✓										✓			✓	✓						
11TWB08										✓					✓							✓						
11TWB12																								✓				
11TWB16																									✓	✓		

How To Order Thorburn Hydro-Demolition Hose Assemblies

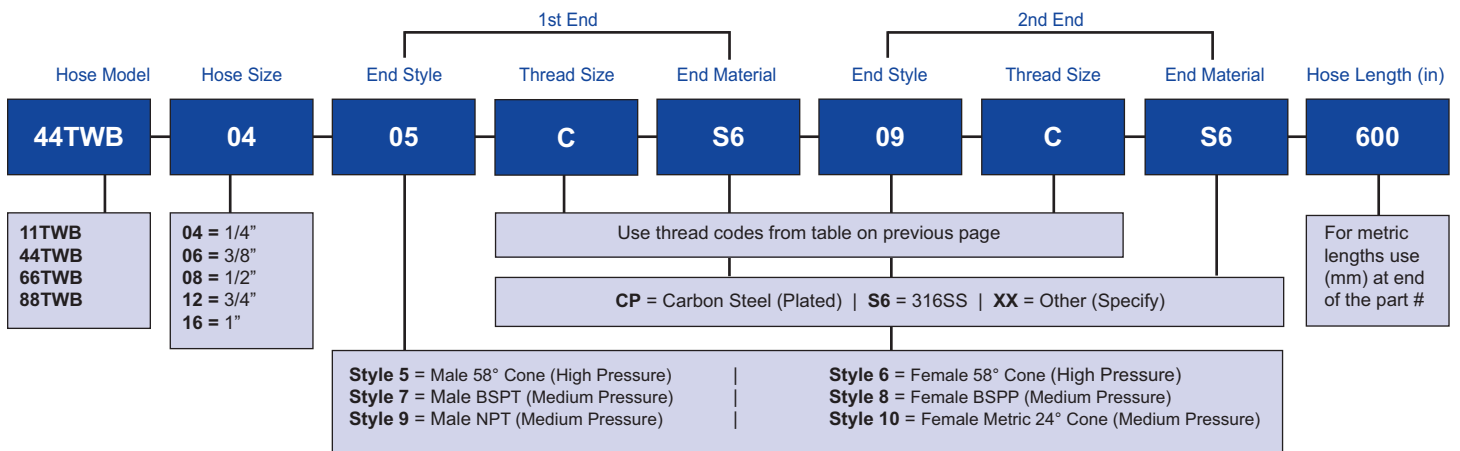

Thorburn TPU High Pressure Lay Flat Discharge Hose Assemblies



Thorburn's TPU lay flat hose assemblies provide flexibility and mobility to streamline efficient use of transferring large volume of liquids. Lay flat hoses can be easily transported by light weight vehicles to remote areas or places with limited infrastructure and can be deployed in harsh environments such as rocky mountain sides, oil spills and deep wells. Lay flat hose assemblies are ideal for rapid large volume dewatering due to less pressure drop over large distances reducing the need for connections. After use, lay flat hoses can be easily dismantled, cleaned, reeled up and relocated to a new site with minimal manual labor.

Features

- Minimal pressure loss & low friction
- Excellent abrasion and chemical resistance
- Transfers large volume of liquid
- Continuous operation at high pressures
- Terrain friendly, follows ground contours
- Easy access to remote areas
- Canadian CRN available upon request (N)

Thorburn Series (N)22TWHD TPU High Pressure Lay Flat Hose

High Pressure TPU Layflat Discharge Hose



Thorburn Series (N)22TWHD: Is designed to provide flexibility and mobility to streamline efficient use of transferring large volume of liquids. Lay flat hose assemblies are ideal for rapid large volume dewatering due to less pressure drop over large distances reducing the need for connections. After use, lay flat hoses can be easily dismantled, cleaned, reeled up and relocated to a new site with minimal manual labor.

Applications: Used for hydraulic fracture water transfer, to replace damaged hydrant lines, or to replace a broken water main, emergency rescue and disaster relief, remote water supply for municipal fire fighting, industrial sewage discharge and river dredging.

Safety Factor: 3:1

Thorburn Part #	Hose I.D.		Design Pressure		Minimum Burst Pressure		Weight	
	mm	in	bar	PSI	bar	PSI	kg/m	lb/ft
(N)22TWHD16	25	1	17	250	52	750	0.20	0.13
(N)22TWHD32	50	2	17	250	52	750	0.29	0.19
(N)22TWHD48	75	3	17	250	52	750	0.45	0.30
(N)22TWHD64	100	4	17	250	52	750	1.0	0.67
(N)22TWHD80	130	5	17	250	52	750	1.2	0.81
(N)22TWHD96	150	6	17	250	52	750	2.0	1.34
(N)22TWHD128	200	8	17	250	52	750	3.0	2.02
(N)22TWHD160	250	10	17	250	52	750	6.0	4.03
(N)22TWHD192	300	12	14	200	41	600	6.2	4.17

N is used in the part number only when a Canadian CRN is required, when a code requirement must be met or material traceability is required. 4:1 Safety Factor required.

Construction

Tube: Smooth TPU (Thermoplastic polyurethane)
Reinforcement: High tensile calendared polyester
Cover: Smooth polyurethane
Cover Color: Black (Standard), Green (G), Blue (B), Yellow (Y), Brown (BR)
Operating Temperature: -50°C (-58°F) to 80°C (176°F)
Maximum Continuous Length: 200 m (656 ft)
Typical Couplings:
 Crimp Style Couplings (Standard)
 Clamp Style Victaulic Couplings
 (See Page 136)

Thorburn Series (N)22TWHP TPU High Pressure Lay Flat Hose

Very High Pressure TPU Discharge Layflat Hose



Thorburn Series (N)22TWHP: Is designed to operate at higher pressures than Thorburn's (N)22TWHD. Built to provide flexibility and mobility to streamline efficient use of transferring large volume of liquids. Lay flat hose assemblies are ideal for rapid large volume dewatering due to less pressure drop over large distances reducing the need for connections. After use, lay flat hoses can be easily dismantled, cleaned, reeled up and relocated to a new site with minimal manual labor.

Applications: Long distance fracking water transfer, industrial dewatering, discharge pumping, water irrigation, manure slurry pumping, wastewater delivery.

Safety Factor: 3:1

Thorburn Part #	Hose I.D.		Design Pressure		Minimum Burst Pressure		Weight	
	mm	in	mm	in	bar	PSI	kg/m	lb/ft
(N)22TWHP64	102	4	29	420	87	1260	1.8	1.21
(N)22TWHP96	152	6	29	420	87	1260	4.0	2.69
(N)22TWHP128	203	8	21	300	62	900	4.2	2.82

N is used in the part number only when a Canadian CRN is required, when a code requirement must be met or material traceability is required. 4:1 Safety Factor required.

Construction

Tube: Smooth TPU (Thermoplastic polyurethane)
Reinforcement: High tensile calendared polyester
Cover: Smooth polyurethane
Cover Color: Black
Operating Temperature: -50°C (-58°F) to 80°C (176°F)
Maximum Continuous Length: 200 m (656 ft)
Typical Couplings:
 Crimp Style Couplings (Standard)
 Clamp Style Victaulic Couplings
 (See Page 136)

Thorburn TPU High Pressure Lay Flat Hose Standard Couplings



Victaulic Groove Style Hose Couplings

- Crimp Style (Standard)(Code 01)
- Clamp Style (Code 02)
- 316SS or aluminum material
- Full Bore design to minimize friction loss and increase flow
- Hard-coat anodized clamp for abrasion resistance
- Sizes: DN 25 (1”) to DN 300 (12”)
- Temperature: -50°C to 80°C (-58°F to 176°F)



Code 01
Crimp Style Victaulic Couplings (Standard)



Code 02
Clamp Style Victaulic Couplings

How To Order Thorburn High Pressure Layflat Hose Assemblies

Model	Size	1st End Coupling	2nd End Coupling	1st End Fitting Material	2nd End Fitting Material	Hose Length (in)
22TWHHD	64	02	02	S6	S6	600
(N)22TWHHD (N)22TWHHP	16 = 1" 32 = 2" 48 = 3" 64 = 4" 80 = 5" 96 = 6" 128 = 8" 160 = 10" 192 = 12"	01 = Victaulic Style (Crimp) 02 = Victaulic Style (Clamp) XX = Specify		S6 = 316SS AL = Aluminum (Anodized)		For metric lengths use (mm) at end of the part #

Thorburn PVC Layflat Water Hose Assemblies



Thorburn Series (N)22TW

Layflat Low Pressure Water Discharge Hose



Thorburn Series (N)22TW: Is a general purpose low to medium pressure versatile PVC lay flat hose that is light weight and easy to maneuver and provides good abrasion, chemical and UV resistance. The smooth PVC tube provides low friction loss and can be rolled up into tight coils for easy storage and transport. Available in continuous lengths of 200m

Applications: Water discharge service for medium duty agriculture, construction, quarries, above ground and below ground mining, drip irrigation, pumps, floating booms, cable covering, industrial washdown, dredge discharge, liquid manure and sludge transfer

Safety Factor: 3:1

Thorburn Part #	Hose I.D.		Hose O.D.		Design Pressure @ 20°C (68°F)		Weight	
	mm	in	mm	in	bar	PSI	kg/m	lb/ft
(N)22TW12	20	3/4	24	0.95	7	100	0.12	0.08
(N)22TW16	25	1	28	1.11	6	85	0.15	0.10
(N)22TW20	30	1 1/4	35	1.37	6	85	0.22	0.15
(N)22TW24	40	1 1/2	41	1.63	5	80	0.22	0.15
(N)22TW32	50	2	54	2.13	4	80	0.30	0.20
(N)22TW40	60	2 1/2	67	2.63	4	80	0.40	0.27
(N)22TW48	75	3	80	3.13	4	70	0.49	0.33
(N)22TW64	100	4	105	4.14	4	70	0.69	0.46
(N)22TW80	125	5	131	5.15	2	50	0.97	0.65
(N)22TW96	150	6	156	6.15	2	50	1.28	0.86
(N)22TW128	200	8	207	8.16	2	45	1.93	1.30
(N)22TW160	250	10	259	10.20	2	35	2.69	1.81
(N)22TW192	300	12	312	12.30	2	30	2.90	1.95
(N)22TW224	350	14	359	14.13	2	30	3.90	2.62
(N)22TW256	400	16	410	16.14	2	30	4.61	3.10

Note: Larger sizes available upon request. Prefix N is used in the part number only when a Canadian CRN is required, when a code requirement must be met or material traceability is required. 4:1 Safety Factor required.

Construction

Tube: Smooth PVC impregnation chemical and UV resistance

Reinforcement: Woven high tensile synthetic yarns

Cover: Blue PVC impregnation (both tube and cover are extruded simultaneously to obtain maximum bonding)

Operating Temperature:

-10°C to 55°C (15°F to 130°F)

Typical Hose End Couplings:

Combination hose shank with clamp (Pg 64)

TB lever couplings with clamp (Pg 78)

TP lever couplings with clamp, (Pg 82)

CamLock with clamp (Pg 141)

Shank with clamp (Pg 142)

FHS fire hose couplings with clamps (Pg 143)

Instantaneous couplings with clamps (Pg 145)

Thorburn PVC Layflat Water Discharge Hose Assemblies



Thorburn Series (N)22TWB

Layflat Water Discharge Hose



Thorburn Series (N)22TWB: Is a durable PVC lay flat hose that provides low friction loss maximum flow, excellent abrasion, chemical and UV resistance allowing for prolonged outdoor use. The hose is designed for applications requiring higher working pressures than Thorburn’s (N)22TW. The smooth PVC tube provides low friction loss and can be rolled up into tight coils for easy storage and transport. Available in continuous lengths of 200m.

Applications: Water discharge service for medium duty agriculture, construction, quarries, above ground and below ground mining, drip irrigation, pumps, floating booms, cable covering, industrial washdown, dredge discharge, liquid manure and sludge transfer.

Safety Factor: 3:1

Thorburn Part #	Hose I.D.		Hose O.D.		Design Pressure @ 20°C (68°F)		Weight	
	mm	in	mm	in	bar	PSI	kg/m	lb/ft
(N)22TWB16	25	1	29	1.13	10	150	0.19	0.13
(N)22TWB24	40	1 1/2	41	1.63	10	150	0.28	0.19
(N)22TWB32	50	2	55	2.15	10	150	0.39	0.26
(N)22TWB40	60	2 1/2	68	2.67	10	150	0.65	0.44
(N)22TWB48	75	3	81	3.19	10	150	0.77	0.52
(N)22TWB64	100	4	108	4.27	9	125	1.1	0.74
(N)22TWB96	150	6	159	6.26	8	115	1.8	1.21
(N)22TWB128	200	8	209	8.24	5	70	2.4	1.61
(N)22TWB160	250	10	257	10.12	4	65	2.9	1.95

Note: Larger sizes available upon request. Prefix N is used in the part number only when a Canadian CRN is required, when a code requirement must be met or material traceability is required. 4:1 Safety Factor required.

Construction

Tube: Smooth, heavy PVC impregnation provides good abrasion, chemical and UV resistance

Reinforcement: Woven high tensile synthetic yarns

Cover: Smooth, Brown PVC impregnation (both tube and cover are extruded simultaneously to obtain maximum bonding)

Operating Temperature:

-10°C to 65°C (15°F to 150°F)

Typical Hose End Couplings:

Combination hose shank with clamp (Pg 64)

TB lever couplings with clamp (Pg 78)

TP lever couplings with clamp, (Pg 82)

CamLock with clamp (Pg 141)

Shank with clamp (Pg 142)

FHS fire hose couplings with clamps (Pg 143)

Instantaneous couplings with clamps (Pg 145)

Thorburn Premium Fire Hose Assemblies



Thorburn Series (N)223TW

Rubber Covered Abrasion Resistant Discharge Hose



Thorburn Series (N)223TW: Is a rubber covered fire hose constructed from specially formulated synthetic nitrile rubber to produce excellent abrasion resistance. The hose is designed with extra thick ribs to protect from wear and abrasion. It can be stored wet and is impervious to mold and mildew. Thorburn's (N)223TW can be used in applications such as, decontamination, wash down and marine fire hose. Underwriters Laboratories of Canada and Underwriters laboratories (UL) 19. Available in 25', 50' and 100' lengths.

Applications: Municipal fire departments, navies, petrochemical, nuclear plants and other industrial services

Construction

Made from circularly woven high tensile synthetic yarn, completely protected and locked in by a tough, highly resistant synthetic nitrile rubber /PVC blend extruded through the weave and forming a single homogenous construction.

Operating Temperature:

-40°C (-40°F) to 60°C (140°F)

Typical Hose End Couplings:

- Hose shanks-clamps/crimped sleeves (Pg 142)
- FHS fire hose couplings-clamps/crimped sleeves (Pg 143)
- Instantaneous couplings-clamps/crimped sleeves (Pg 145)
- Camlock couplings-clamps/crimped sleeves (Pg 141)
- Fire hose adapters (Pg 151)
- Fire hose nozzles (Pg 158)

Safety Factor: 3:1

Thorburn Part #	Hose I.D.		Design Pressure		Minimum Burst Pressure		Weight	
	mm	in	bar	PSI	bar	PSI	kg/m	lb/ft
(N)223TW24	40	1 1/2	21	300	62	900	0.45	0.30
(N)223TW28	45	1 3/4	21	300	62	900	0.48	0.32
(N)223TW40	60	2 1/2	21	300	62	900	0.67	0.45

N is used in the part number only when a Canadian CRN is required, when a code requirement must be met or material traceability is required. 4:1 Safety Factor required.

Thorburn Series (N)224TW Premium Fire Hose Assemblies

Premium Single Jacket Fabric Discharge Hose



Thorburn Series (N)224TW: Is a premium single jacket fire hose that has one woven polyester jacket glued to the outside of the rubber liner to protect the rubber liner. The single jacket hose is light weight which can be important in applications such as fighting forestry fires where the hose is often carried on foot by firefighters. Standard lengths are 50' (15M) and 100' (30M).

Applications: Light use applications, temporary jobs or on a non-abrasive surface such as grass, exterior hoses for emergency fire protection in most industrial applications.

Construction

Thermoplastic extruded PU lining reinforced with high tensile polyester yarn. Thoroughly impregnated with the TPU polymer Color white

Operating Temperature:

-40°C (-40°F) to 65°C (150°F)

Typical Hose End Couplings:

- Hose shanks-clamps/crimped sleeves (Pg 142)
- FHS fire hose couplings-clamps/crimped sleeves (Pg 143)
- Instantaneous couplings-clamps/crimped sleeves (Pg 145)
- Camlock couplings-clamps/crimped sleeves (Pg 141)
- Expansion ring couplings (Pg 149)
- Fire hose adapters (Pg 151)
- Fire hose nozzles (Pg 158)

Safety Factor: 3:1

Thorburn Part #	Hose I.D.		Design Pressure		Minimum Burst Pressure		Weight	
	mm	in	bar	PSI	bar	PSI	kg/m	lb/ft
(N)224TW16	25	1	21	300	62	900	11.3	7.6
(N)224TW24	40	1 1/2	21	300	62	900	19.2	12.9
(N)224TW32	50	2	21	300	62	900	23.2	15.6
(N)224TW40	60	2 1/2	21	300	62	900	33.9	22.8

N is used in the part number only when a Canadian CRN is required, when a code requirement must be met or material traceability is required. 4:1 Safety Factor required.

Thorburn Series (N)225TW Premium Fire Hose Assemblies

Premium Double Jacket Fabric Discharge Hose



Thorburn Series (N)225TW: Is a double-jacket fire hose that has an extra layer of synthetic fabric that allows for higher working pressure and increased durability. The hose can be run over with large trucks without bursting, even while pressurized. The woven polyester jacket material never needs drying and can be stored wet since it is immune to mold and rot and can be stored for long periods of time without degradation. Conform to National Fire Protection Association NFPA 1961 Available in 25', 50' and 100' lengths.

Applications: Municipal fire departments, industrial fire brigades, shipboard fire fighting.

Construction

EPDM blend lining, reinforced with a White Double jacket polyester yarn

Operating Temperature:

-40°C (-40°F) to 82°C (180°F)

Typical Hose End Couplings:

- Hose shanks-clamps/crimped sleeves (Pg 142)
- FHS fire hose couplings-clamps/crimped sleeves (Pg 143)
- Instantaneous couplings-clamps/crimped sleeves (Pg 145)
- Camlock couplings-clamps/crimped sleeves (Pg 141)
- Expansion ring couplings (Pg 149)
- Fire hose adapters (Pg 151)
- Fire hose nozzles (Pg 158)

Safety Factor: 3:1

Thorburn Part #	Hose I.D.		Design Pressure		Minimum Burst Pressure		Weight	
	mm	in	bar	PSI	bar	PSI	kg/m	lb/ft
(N)225TW24	40	1 1/2	28	400	83	1200	0.52	0.35
(N)225TW40	60	2 1/2	28	400	83	1200	0.86	0.58

N is used in the part number only when a Canadian CRN is required, when a code requirement must be met or material traceability is required. 4:1 Safety Factor required.

Hose Shank Couplings For PVC Layflat and Fire Hose



Pin Lug Hose Shanks

Thorburn's Anti-leak pin lug hose shank couplings connect with a hose shank and connect together with a threaded swivel nut that is included on the female side of the coupling. These couplings are designed to prevent leaks when installed in layflat hose and is used on low pressure suction and discharge applications. The pin lugs (for sizes 3" to 8" models) make it easy to tighten by hand or with a spanner tool.

Camlock Hose Shanks

Thorburn's Aluminum cam lock fittings are lightweight and are corrosion and abrasion resistant and designed to prevent leaks when installed in layflat hose. The seal is made of NBR (Buna-N) rubber. Buna-N seals are resistant to fuel, oil, and other chemicals.

Construction

Aluminum - ASTM B85 Grade 383

Features

Rubber Seals - Help prevent leakage.

Versatile - Suitable for use with other PVC and Rubber Hoses.

Note: To insure proper sealing attach band clamps directly over rubber seals.

Style 633D-LF | Camlock Female Coupler Type-C Aluminum Hose Shank (Code 01)



Part Number	Nominal Hose I.D.	
	Inch	mm
633D-24LF-AL	1 1/2	38
633D-32LF-AL	2	51
633D-40LF-AL	2 1/2	64
633D-48LF-AL	3	76
633D-64LF-AL	4	102
633D-96LF-AL	6	152
633D-128LF-AL	8	203

Hose Shank Couplings For PVC Layflat and Fire Hose

Style 633E-LF | Camlock Male Adapter Type E - Aluminum Hose Shank (Code 02)



Part Number	Nominal Hose I.D.	
	Inch	mm
633E-24LF-AL	1 1/2	38
633E-32LF-AL	2	51
633E-40LF-AL	2 1/2	64
633E-48LF-AL	3	76
633E-64LF-AL	4	102
633E-96LF-AL	6	152
633E-128LF-AL	8	203

Style 15I-LF | Female Pin Lug - Aluminum Hose Shank with Brass Swivel Nut Female (NPSM) (Code 03)



Part Number	Nominal Hose I.D.	
	Inch	mm
15I-24LF-AB	1 1/2	38
15I-32LF-AB	2	51
15I-40LF-AB	2 1/2	64
15I-48LF-AB	3	76
15I-64LF-AB	4	102
15I-96LF-AB	6	152
15I-128LF-AB	8	203

Style 16I-LF | Male Pin Lug - Aluminum Hose Shank Male (NPSM) (Code 04)



Part Number	Nominal Hose I.D.	
	Inch	mm
16I-24LF-AL	1 1/2	38
16I-32LF-AL	2	51
16I-40LF-AL	2 1/2	64
16I-48LF-AL	3	76
16I-64LF-AL	4	102
16I-96LF-AL	6	152
16I-128LF-AL	8	203

Pin lugs for sizes 3 to 8 inches

Thorburn Series FHS Fire Hose Couplings



Thorburn Series FHS are Storz type full flow couplings with a bayonet locking system protected by a collar and are designed for use as fire hose fittings. They can be connected by plugging the lug parts into each other and then twisting against each other and can also be used as connecting couplings for connecting other hose types. Thorburn Series FHS have wide usage in many industries, including refineries, agricultural, construction, maritime safety, and military use due to their resistance against corrosion, acids, and water. Made of Aluminum.

Features

- Couplings are forged making them stronger than casting
- Maximum operating pressure of 16 bar (232 psi)
- Easy to assemble and disassemble manually
- Couplings are fitted with an NBR seal (Standard).

(Other seals to seals to suit specific applications are available)

Style SHS | Hose Shank (Code 05)



Note: Can be attached to Thorburn Styles SMA, SFA, SBC. Requires a clamp or ferrule to secure hose shank fittings to a hose. (See Page 98 to 110)

Thorburn Part #	Hose ID		Claw Distance	
	in	mm	in	mm
FHS12SHS31-AL	3/4	19	1.2	31
FHS16SHS31-AL	1	25	1.2	31
FHS16SHS66-AL	1	25	2.6	66
FHS20SHS44-AL	1 1/4	32	1.7	44
FHS20SHS66-AL	1 1/4	32	2.6	66
FHS24SHS51-AL	1 1/2	38	2.0	51
FHS24SHS66-AL	1 1/2	38	2.6	66
FHS28SHS66-AL	1 3/4	45	2.6	66
FHS32SHS66-AL	2	51	2.6	66
FHS40SHS89-AL	2 1/2	63	3.5	89
FHS48SHS89-AL	3	76	3.5	89
FHS64SHS115-AL	4	102	4.5	115
FHS64SHS133-AL	4	102	5.2	133
FHS69SHS133-AL	4 5/16	110	5.2	133
FHS80SHS148-AL	5	127	5.8	148
FHS96SHS160-AL	6	152	6.3	160

Style SMA | Male BSPP (Code 05A)



Thorburn Part #	Hose ID		Claw Distance Internal		Thread Type	Thread in
	in	mm	in	mm		
16SMA31-12-AL	1	25	1.2	31	BSPP	3/4
16SMA31-16-AL	1	25	1.2	31	BSPP	1
20SMA44-20-AL	1 1/4	32	1.7	44	BSPP	1 1/4
24SMA51-24-AL	1 1/2	38	2.0	51	BSPP	1 1/2
24SMA66-16-AL	2	52	2.6	66	BSPP	1
28SMA66-20-AL	2	52	2.6	66	BSPP	1 1/4
32SMA66-24-AL	2	52	2.6	66	BSPP	1 1/2
32SMA66-32-AL	2	52	2.6	66	BSPP	2
48SMA89-40-AL	3	75	3.5	89	BSPP	2 1/2
64SMA89-64-AL	3	75	3.5	89	BSPP	3
64SMA115-64-AL	4	100	4.5	115	BSPP	4
69SMA133-64-AL	4 5/16	110	5.2	133	BSPP	4

Thorburn Fire Hose Couplings

Style SFA | Female BSPP (Code 05B)



Thorburn Part #	Hose ID		Claw Distance Internal		Thread Type	Thread in
	in	mm	in	mm		
FHS16SFA31-08-AL	1	25	1.2	31	BSPP	1/2
FHS16SFA31-12-AL	1	25	1.2	31	BSPP	3/4
FHS16SFA31-16-AL	1	25	1.2	31	BSPP	1
FHS20SFA44-20-AL	1 1/4	32	1.7	44	BSPP	1 1/4
FHS24SFA51-32-AL	1 1/2	38	2.0	51	BSPP	2
FHS32SFA66-16-AL	2	52	2.6	66	BSPP	1
FHS32SFA66-20-AL	2	52	2.6	66	BSPP	1 1/4
FHS32SFA66-24-AL	2	52	2.6	66	BSPP	1 1/2
FHS32SFA66-32-AL	2	52	2.6	66	BSPP	2
FHS32SFA66-40-AL	2	52	2.6	66	BSPP	2 1/2
FHS40SFA81-40-AL	2 1/2	65	3.2	81	BSPP	2 1/2
FHS48SFA89-32-AL	3	75	3.5	89	BSPP	2
FHS48SFA89-40-AL	3	75	3.5	89	BSPP	2 1/2
FHS48SFA89-48-AL	3	75	3.5	89	BSPP	3
FHS64SFA115-64-AL	4	100	4.5	115	BSPP	4
FHS69SFA133-64-AL	4 5/16	110	5.2	133	BSPP	4
FHS80SFA148-80-AL	5	125	5.8	148	BSPP	5
FHS96SFA160-96-AL	6	150	6.3	160	BSPP	6

Style SBC | Blank Cap with Chain (Code 05C)



Thorburn Part #	Hose ID		Claw Distance	
	in	mm	in	mm
FHS16SBC31-AL	1	25	1.2	31
FHS20SBC44-AL	1 1/4	32	1.7	44
FHS24SBC51-AL	1 1/2	38	2.0	51
FHS32SBC66-AL	2	52	2.6	66
FHS40SBC81-AL	2 1/2	65	3.2	81
FHS48SBC89-AL	3	75	3.5	89
FHS64SBC115-AL	4	100	4.5	115
FHS69SBC133-AL	4 5/16	110	5.2	133
FHS96SBC160-AL	6	150	6.3	160

Style TSS-1 / TSS-2 | Spanner Tool



Thorburn Part #	Hose ID	
	in	mm
TSS-1	1	25
	1 1/2	38
	2	51
	2 1/2	63
	3	76
TSS-2	4	102
	5	127
	6	152

Thorburn Series TIC Instantaneous Couplings



Thorburn Series “TIC” instantaneous couplings provide a straight forward solution to connect many lengths of hose together. The male couplings connects together with a female coupling that has a spring loaded latch that clips behind the lip of the male coupling. The couplings can be easily disconnected by pulling the two latch release handles on the female coupling. Aluminum hose couplings have the advantage of light weight, while brass hose couplings are stronger and more resistant to cracking during installation. Maximum working pressure is 16 bar (232 PSI) and are available in a variety of different size hose stems, BSPP male and female threads. Thorburn instantaneous couplings come with a 2½" (65mm) nominal male and nominal female I.D. standard for all sizes shown and are manufactured in accordance with BS 336.

Note: Requires a clamp or ferrule to secure shank coupling to a hose under pressure. (See pages 98 to 110).

Style TIC-FHS-MHS | Complete Set - Male-Female Hose Stem (Code 06)



Designed with two internal mechanisms that clasp to the lip of the male. They are available with hose tails ranging from 1½" up to 3".

Thorburn Part #	Hose Stem Size		Material
	in	mm	
TIC-FHS-MHS-24-AL	1 1/2	38	Aluminum
TIC-FHS-MHS-32-AL	2	50	Aluminum
TIC-FHS-MHS-40-AL	2 1/2	64	Aluminum
TIC-FHS-MHS-48-AL	3	76	Aluminum
TIC-FHS-MHS-24-BB	1 1/2	38	Brass
TIC-FHS-MHS-32-BB	2	50	Brass
TIC-FHS-MHS-40-BB	2 1/2	64	Brass
TIC-FHS-MHS-48-BB	3	76	Brass

Style TIC-FHS | Female Hose Stem (Code 07)



Designed with two internal mechanisms that clasp to the lip of the male. Available with hose tails ranging from 1½" up to 3".

Thorburn Part #	Hose Stem Size		Material
	in	mm	
TIC-FHS-24-AL	1 1/2	38	Aluminum
TIC-FHS-32-AL	2	50	Aluminum
TIC-FHS-40-AL	2 1/2	64	Aluminum
TIC-FHS-48-AL	3	76	Aluminum
TIC-FHS-24-BB	1 1/2	38	Brass
TIC-FHS-32-BB	2	50	Brass
TIC-FHS-40-BB	2 1/2	64	Brass
TIC-FHS-48-BB	3	76	Brass

Thorburn Series TIC Instantaneous Couplings

Style TIC-MHS | Mail Hose Stem (Code 08)



Connects into a female instantaneous coupling and provides a connection to a length of hose. Available with hose tails ranging from 1½" up to 3".

Thorburn Part #	Hose Stem Size		Material
	in	mm	
TIC-MHS-24-AL	1 1/2	38	Aluminum
TIC-MHS-32-AL	2	50	Aluminum
TIC-MHS-40-AL	2 1/2	64	Aluminum
TIC-MHS-48-AL	3	76	Aluminum
TIC-MHS-24-BB	1 1/2	38	Brass
TIC-MHS-32-BB	2	50	Brass
TIC-MHS-40-BB	2 1/2	64	Brass
TIC-MHS-48-BB	3	76	Brass

Style TIC-FFT | Female X Female Threads (Code 09)



Connects a male instantaneous coupling to a male BSPP. Available with female BSPP threads ranging from 1½" up to 3"

Thorburn Part #	BSPP Hose Thread Size		Material
	in	mm	
TIC-FFT-24-AL	1 1/2	38	Aluminum
TIC-FFT-32-AL	2	50	Aluminum
TIC-FFT-40-AL	2 1/2	64	Aluminum
TIC-FFT-48-AL	3	76	Aluminum
TIC-FFT-24-BB	1 1/2	38	Brass
TIC-FFT-32-BB	2	50	Brass
TIC-FFT-40-BB	2 1/2	64	Brass
TIC-FFT-48-BB	3	76	Brass

Style TIC-FMT | Female X Male Threads (Code 10)



Connects a male instantaneous fitting and a female BSPP. Available with male threads ranging from 1½" up to 3".

Thorburn Part #	BSPP Hose Thread Size		Material
	in	mm	
TIC-FFT-24-AL	1 1/2	38	Aluminum
TIC-FFT-32-AL	2	50	Aluminum
TIC-FFT-40-AL	2 1/2	64	Aluminum
TIC-FFT-48-AL	3	76	Aluminum
TIC-FFT-24-BB	1 1/2	38	Brass
TIC-FFT-32-BB	2	50	Brass
TIC-FFT-40-BB	2 1/2	64	Brass
TIC-FFT-48-BB	3	76	Brass

Thorburn Series TIC Instantaneous Couplings

Style TIC-MFT | Male X Female Threads (Code 11)



Connects to a female instantaneous coupling and a male BSPP thread. Available with female threads ranging from 1½" up to 3".

Thorburn Part #	BSPP Hose Thread Size		Material
	in	mm	
TIC-MFT-24-AL	1 1/2	38	Aluminum
TIC-MFT-32-AL	2	50	Aluminum
TIC-MFT-40-AL	2 1/2	64	Aluminum
TIC-MFT-48-AL	3	76	Aluminum
TIC-MFT-24-BB	1 1/2	38	Brass
TIC-MFT-32-BB	2	50	Brass
TIC-MFT-40-BB	2 1/2	64	Brass
TIC-MFT-48-BB	3	76	Brass

Style TIC-MMT | Male X Male Threads (Code 12)



Connects to a female instantaneous coupling and a female BSPP. Available with male threads ranging from 1½" up to 3".

Thorburn Part #	BSPP Hose Thread Size		Material
	in	mm	
TIC-MMT-24-AL	1 1/2	38	Aluminum
TIC-MMT-32-AL	2	50	Aluminum
TIC-MMT-40-AL	2 1/2	64	Aluminum
TIC-MMT-48-AL	3	76	Aluminum
TIC-MMT-24-BB	1 1/2	38	Brass
TIC-MMT-32-BB	2	50	Brass
TIC-MMT-40-BB	2 1/2	64	Brass
TIC-MMT-48-BB	3	76	Brass

Style TIC-MMA | Male X Male Adapter (Code 13)



Designed to provide a connection between two BS 336 female instantaneous coupling. Available in a standard instantaneous size option of 2½".

Thorburn Part #	Adapter Size		Material
	in	mm	
TIC-MMA-40-AL	2 1/2	64	Aluminum
TIC-MMA-40-BB	2 1/2	64	Brass

Thorburn Series TIC Instantaneous Couplings

Style TIC-FFA | Female X Female Adapter (Code 14)



Adapter has two spring mechanisms that clasp to the lips of two BS 336 male fire couplings. Available in a standard size of 2½".

Thorburn Part #	Adapter Size		Material
	in	mm	
TIC-FFA-40-AL	2 1/2	64	Aluminum
TIC-FFA-40-BB	2 1/2	64	Brass

Style TIC-P | Plug (Code 15)



Connects to a female instantaneous coupling and designed to seal off water supplies and prevent dirt from entering the connection. Available in a standard instantaneous size of 2½".

Thorburn Part #	Plug Size		Material
	in	mm	
TIC-P-40-AL	2 1/2	64	Aluminum
TIC-C-40-BB	2 1/2	64	Brass

Style TIC-C | Cap (Code 16)



Connects to a male instantaneous coupling and are used to close off hoses or piping. Available in a standard instantaneous size of 2½".

Thorburn Part #	Cap Size		Material
	in	mm	
TIC-C40-AL	2 1/2	64	Aluminum
TIC-C-40-BB	2 1/2	64	Brass

Style TIC-RS | Replacement EPDM Seal



Replacement EPDM seals insert inside the female instantaneous coupling. Available in a standard size of 2½".

Thorburn Part #	Seal Size		Material
	in	mm	
TIC-RS-40	2 1/2	64	EPDM Blend

Thorburn Series TERC Expansion Ring Couplings

Thorburn Series TERC expansion ring couplings are made of light weight extruded aluminum with a hard anodized finish and designed with three rocker lugs on the male end swivel and the female end swivel. Thorburn Series TERC expansion ring couplings are complete with expansion rings, swivel and tail gaskets. Expansion ring couplings are typically used for municipal and industrial fire hose.

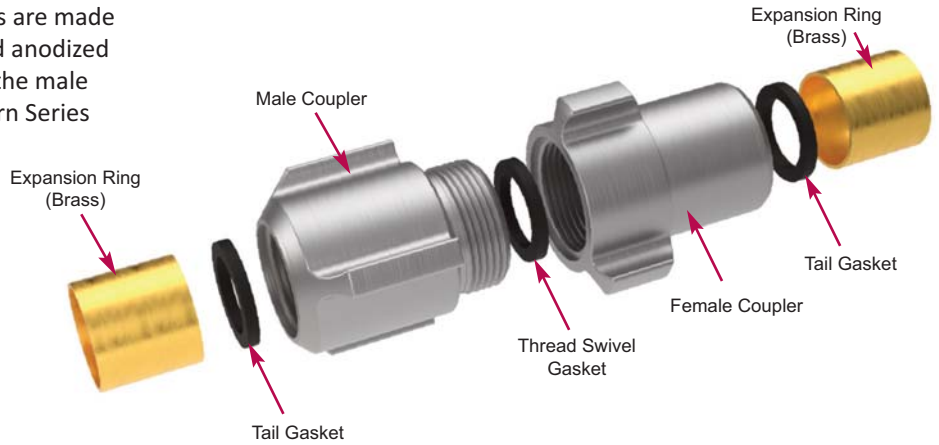

Style TERCS | Expansion Ring Coupling - Used with Single Jacket Layflat Hose (Code 17)



Thorburn Part #		Size	Bowl	Thread
Aluminum	Brass	in	in	
TERCS-16-20-NPSH-AL		1	1 1/4	NPSH
TERCS-24-28-NPSH-AL	TERCS-24-28-NPSH-BB	1 1/2	1 3/4	NPSH
TERCS-24-27-NPSH-AL		1 1/2	1 11/16	NPSH
TERCS-24-29-NPSH-AL	TERCS-24-29-NPSH-BB	1 1/2	1 13/16	NPSH
TERCS-32-36-NPSH-AL		2	2 1/4	NPSH
TERCS-40-45-NPSH-AL	TERCS-40-45-NPSH-BB	2 1/2	2 13/16	NPSH
TERCS-24-27-NST-AL		1 1/2	1 11/16	NST (NH)
TERCS-24-28-NST-AL	TERCS-24-28-NST-BB	1 1/2	1 3/4	NST (NH)
TERCS-24-29-NST-AL	TERCS-24-29-NST-BB	1 1/2	1 13/16	NST (NH)
TERCS-40-43-NST-AL		2 1/2	2 11/16	NST (NH)
TERCS-40-45-NST-AL	TERCS-40-45-NST-BB	2 1/2	2 13/16	NST (NH)
TERCS-24-27-MNPT-AL		1 1/2	1 11/16	MNPT
TERCS-24-28-MNPT-AL		1 1/2	1 3/4	MNPT
TERCS-32-36-MNPT-AL		2	2 1/4	MNPT
TERCS-40-43-MNPT-AL		2 1/2	2 11/16	MNPT

Style TERCD | Expansion Ring Coupling - Used with Double Jacket Layflat Hose (Code 18)



Thorburn Part #		Size	Bowl	Thread
Aluminum	Brass	in	in	
TERCD-24-29-NPSH-AL		1 1/2	1 13/16	NPSH
TERCD-24-31-NPSH-AL	TERCD-24-31-NPSH-BB	1 1/2	1 15/16	NPSH
TERCD-24-33-NPSH-AL		1 1/2	2 1/16	NPSH
TERCD-32-37-NPSH-AL		2	2 5/16	NPSH
TERCD-40-48-NPSH-AL		2 1/2	3	NPSH
TERCD-24-29-NST-AL		1 1/2	1 13/16	NST (NH)
TERCD-24-31-NST-AL	TERCD-24-31-NST-BB	1 1/2	1 15/16	NST (NH)
TERCD-24-33-NST-AL		1 1/2	2 1/16	NST (NH)
TERCD-40-46-NST-AL		2 1/2	2 7/8	NST (NH)
TERCD-40-48-NST-AL		2 1/2	3	NST (NH)
TERCD-24-29-MNPT-AL		1 1/2	1 13/16	MNPT
TERCD-32-37-MNPT-AL		2	2 5/16	MNPT
TERCD-40-46-MNPT-AL		2 1/2	2 7/8	MNPT

Thorburn Series TERC Expansion Ring Couplings

Style TER | Expansion Ring



Thorburn Part #	Size OD	Length	Wall Thickness
Brass	in	in	in
TER-16-20-BB	1	1 1/4	0.05
TER-24-12-BB	1 1/2	3/4	0.05
TER-24-14-BB	1 1/2	7/8	0.05
TER-24-16-BB	1 1/2	1	0.05
TER-24-20-BB	1 1/2	1 1/4	0.05
TER-28-20-BB	1 3/4	1 1/4	0.05
TER-40-20-BB	2 1/2	1 1/4	0.62
TER-40-24-BB	2 1/2	1 1/2	0.62
TER-48-32-BB	3	2	0.07

Style TERSG | Replacement Swivel Gasket -Buna N Material



Thorburn Part #	Size ID	Size OD	Thickness
	in	in	in
TERSG-17	1 1/16	1 7/16	1/8
TERSG-25	1 9/16	2 1/16	1/8
TERSG-33	2 1/16	2 1/2	1/8
TERSG-41	2 9/16	3 3/16	3/16
TERSG-49	3 1/16	3 3/4	1/4
TERSG-65	4 1/16	5 1/8	1/4
TERSG-73	4 9/16	5 7/8	1/4
TERSG-81	5 1/16	6 3/8	1/4
TERSG-97	6 1/16	7 1/8	1/4

Style TERTG | Replacement Tail Gasket -Buna N Material



Thorburn Part #	Size ID	Size OD	Thickness
	in	in	in
TERTG-16.5	1 1/32	1 5/16	3/16
TERTG-25	1 9/16	1 3/4	3/16
TERTG-25A	1 9/16	1 15/16	3/16
TERTG-26	1 5/8	2 1/8	3/16
TERTG-41	2 9/16	3	1/4
TERTG-42	2 5/8	3 1/4	1/4
TERTG-50	3 1/8	3 25/32	1/4

Thorburn Fire Hose Adapters



Fire departments have special threaded fire hoses and fire hydrants therefore adapters must be used. The most common thread type in use by Fire Departments today is National Hose (NH aka NST). Thorburn fire hose adapters are made in three categories...

Female to Male Fire Adapters are typically used to change threads and sizes ranging from garden hose threads (3/4 inches) up to 6 inches.

Female to Female Fire Adapters are used to connect two adapters or hoses together, or connect in-line accessories such as a test gauges. They are also used as reducers from a larger connection to a smaller one.

Male to Male Fire Adapters are used for connecting two different threads or sizes together and are useful at connecting Y-valves, in-line ball valves, and strainers.

Thorburn fire hose adapters are available with National Hose (NH), National Pipe Standard Hose (NPSH), Garden Hose Threads (GHT), National Pipe Thread (NPT).

Thorburn Series TFSA Swivel Adapters - Pin Lug

Style TFSA-OS | Female Swivel Adapter - Open Snoot Pin Lug (Code 19)



Thorburn Part #	Female Swivel Thread	Female Rigid Thread
TFSA-OS-24NST-24NPT-BB	1 1/2 - NST (NH)	1 1/2 - NPT
TFSA-OS-24NPSH-24NPT-BB	1 1/2 - NPSH	1 1/2 - NPT
TFSA-OS-40NST-24NPT-BB	2 1/2 - NST (NH)	1 1/2 - NPT
TFSA-OS-40NST-32NPT-BB	2 1/2 - NST (NH)	2 - NPT
TFSA-OS-40NST-40NPT-BB	2 1/2 - NST (NH)	2 1/2 - NPT
TFSA-OS-40NST-40NPT-BB	2 1/2 - NST (NH)	2 1/2 - NPT
TFSA-OS-40NST-40NPT-BB	2 1/2 - NST (NH)	2 1/2 - NPT
TFSA-OS-40NPSH-40NPT-BB	2 1/2 - NPSH	2 1/2 - NPT
TFSA-OS-40NST-48NPT-BB	2 1/2 - NST (NH)	3 - NPT
TFSA-OS-48NST-48NPT-BB	3 - NST (NH)	3 - NPT
TFSA-OS-64NST-64NPT-BB	4 - NST (NH)	4 - NPT

Style TFSA-D | Female Swivel Adapter - Double Pin Lug (Code 20)



Thorburn Part #	Female Swivel Thread	Female Swivel Thread
TFSA-D-24NPSH-24NPSH-BB	1 1/2 - NPSH	1 1/2 - NPSH
TFSA-D-40NPSH-40NPSH-BB	2 1/2 - NPSH	2 1/2 - NPSH
TFSA-D-24NST-24NST-BB	1 1/2 - NST (NH)	1 1/2 - NST (NH)
TFSA-D-40NST-40NST-BB	2 1/2 - NST (NH)	2 1/2 - NST (NH)
TFSA-D-24NST-24NPSH-BB	1 1/2 - NST (NH)	1 1/2 - NPSH
TFSA-D-40NST-40NPSH-BB	2 1/2 - NST (NH)	2 1/2 - NPSH

Thorburn Series THA Hydrant Adapters - Pin Lug

Style THA | Hydrant Adapters - Pin Lug
- Female to Male (Code 21)



Thorburn Part #	Male Thread	Female Thread	
THA-12GHT-24NPSH-BB	3/4 - GHT	1 1/2 - NPSH	
THA-12NPSH-24NPSH-BB	3/4 - NPSH		
THA-12NPT-24NPSH-BB	3/4 - NPT		
THA-16NPSH-24NPSH-BB	1 - NPSH		
THA-16NPT-24NPSH-BB	1 - NPT		
THA-24NPT-24NPSH-BB	1 1/2 - NPT		
THA-24NST-24NPSH-BB	1 1/2 - NST (NH)		
THA-24NPSH-24NPT-BB	1 1/2 - NPSH	1 1/2 - NPT	
THA-24NST-24NPT-BB	1 1/2 - NST (NH)		
THA-12GST-24NST-BB	3/4 - GST		
THA-12NPT-24NST-BB	3/4 - NPT	1 1/2 - NST (NH)	
THA-16NPSH-24NST-BB	1 - NPSH		
THA-16NST-24NST-BB	1 - NST (NH)		
THA-16NPT-24NST-BB	1 - NPT		
THA-24NPSH-24NST-BB	1 1/2 - NPSH		
THA-24NPT-24NST-BB	1 1/2 - NPT		
THA-24NST-24NST-BB	1 1/2 - NST (NH)		
THA-40NST-24NST-BB	2 1/2 - NST (NH)		
THA-24NPSH-24NST-BB	1 1/2 - NPSH		
THA-24NPSH-24NST-BB	1 1/2 - NPT		
THA-24NST-24NST-BB	1 1/2 - NST (NH)		
THA-40NST-24NST-BB	2 1/2 - NST (NH)		
THA-24NPSH-32NPSH-BB	1 1/2 - NPSH		2 - NPSH
THA-24NPT-32NPSH-BB	1 1/2 - NPT		
THA-24NST-32NPSH-BB	1 1/2 - NST (NH)		
THA-40NST-32NPSH-BB	2 1/2 - NST (NH)		
THA-40NST-32NPT-BB	2 1/2 - NST (NH)		
THA-40NST-32NST-BB	2 1/2 - NST (NH)	2 - NPT	
THA-16NPT-40NPSH-BB	1 - NPT	2 - NST (NH)	
THA-24NPSH-40NPSH-BB	1 1/2 - NPSH		
THA-24NPT-40NPSH-BB	1 1/2 - NPT	2 1/2 - NPSH	
THA-24NST-40NPSH-BB	1 1/2 - NST (NH)		
THA-40NST-40NPSH-BB	2 1/2 - NST (NH)		
THA-12GHT-40NST-BB	3/4 - GHT		2 1/2 - NST (NH)
THA-12NPT-40NST-BB	3/4 - NPT		
THA-16NPSH-40NST-BB	1 - NPSH		
THA-16NST-40NST-BB	1 - NST (H)		
THA-16NPT-40NST-BB	1 - NPT		
THA-24NPSH-40NST-BB	1 1/2 - NPSH		
THA-24NST-40NST-BB	1 1/2 - NST (NH)		
THA-24NPT-40NST-BB	1 1/2 - NPT		
THA-32NPSH-40NST-BB	2 - NPSH		
THA-32NST-40NST-BB	2 - NST (NH)		
THA-32NPT-40NST-BB	2 - NPT		
THA-40NPSH-40NST-BB	2 1/2 - NPSH		
THA-40NST-40NST-BB	2 1/2 - NST (NH)		
THA-40NPT-40NST-BB	2 1/2 - NPT		
THA-48NPSH-40NST-BB	3 - NPSH		
THA-48NST-40NST-BB	3 - NST (NH)		
THA-48NPT-40NST-BB	3 - NPT		
THA-40NST-48NPSH-BB	2 1/2 - NST (NH)	3 - NPSH	
THA-40NPT-48NPSH-BB	2 1/2 - NPT		
THA-24NPSH-48NST-BB	1 1/2 - NPSH	3 - NST (NH)	
THA-24NST-48NST-BB	1 1/2 - NST (NH)		
THA-40NST-48NST-BB	2 1/2 - NST (NH)		
THA-40NST-64NST-BB	2 1/2 - NST (NH)	4 - NST (NH)	
THA-40NST-72NST-BB	2 1/2 - NST (NH)	4 - 1/2 NST (NH)	

Thorburn Series TFMHN Female to Male Hex Nipples

Style TFMHN | Hex Nipples
- Female to Male (Code 22)



Thorburn Part #	Male Thread	Female Thread
TFMHN-16NPT-12GHT-BB	1 - NPT	3/4 - GHT
TFMHN-12GHT-16NPSH-BB	3/4 - GHT	1 - NPSH
TFMHN-12GHT-16NPT-BB	3/4 - GHT	1 - NPT
TFMHN-16NPSH-16NPT-BB	1 - NPSH	
TFMHN-16NST-16NPT-BB	1 - NST (NH)	
TFMHN-24NPSH-16NPT-BB	1 1/2 - NPSH	
TFMHN-24NST-16NPT-BB	1 1/2 - NST (NH)	
TFMHN-16NPT-16NST-BB	1 - NPT	
TFMHN-24NPSH-24NPT-BB	1 1/2 - NPSH	1 1/2 - NPT
TFMHN-24NST-24NPT-BB	1 1/2 - NST (NH)	
TFMHN-40NST-24NPT-BB	2 1/2 - NST (NH)	
TFMHN-24NPSH 24NST-BB	1 1/2 - NPSH	1 1/2 - NST(NH)
TFMHN-24NPT 24NST-BB	1 1/2 - NPT	
TFMHN-32NPT-24NST-BB	2 - NPT	
TFMHN-40NPT-24NST-BB	2 1/2 - NPT	
TFMHN-40NST-24NST-BB	2 1/2 - NST (NH)	
TFMHN-24NST-24NST-BB	1 1/2 - NST (NH)	
TFMHN-24NST-24NPSH-BB	1 1/2 - NST (NH)	1 1/2 - NPSH
TFMHN-24NPT-24NPSH-BB	1 1/2 - NPT	
TFMHN-32NPT-24NPSH-BB	2 - NPT	
TFMHN-24NPSH-32NPSH-BB	1 1/2 - NPSH	2 - NPSH
TFMHN-24NST-32NPSH-BB	1 1/2 - NST (NH)	
TFMHN-24NPT-32NPSH-BB	1 1/2 - NPT	
TFMHN-32NPT-32NPSH-BB	2 - NPT	
TFMHN-40NST-32NPSH-BB	2 1/2 - NST (NH)	2 - NPT
TFMHN-24NPSH-32NPT-BB	1 1/2 NPSH	
TFMHN-24NST-32NPT-BB	1 1/2 NST (NH)	
TFMHN-32NPSH-32NPT-BB	2 NPSH	
TFMHN-40NST-32NPT-BB	2 1/2 NST (NH)	2 1/2 NST (NH)
TFMHN-12NPT-40NST-BB	3/4 NPT	
TFMHN-16NPT-40NST-BB	1 - NPT	
TFMHN-24NST-40NST-BB	1 1/2 - NST (NH)	
TFMHN-24NPT-40NST-BB	1 1/2 - NPT	
TFMHN-32NPT-40NST-BB	2 - NPT	
TFMHN-24NST-40NST-BB	1 1/2 - NST (NH)	2 1/2 - NPT
TFMHN-40NPSH-40NPT-BB	2 1/2 - NPSH	
TFMHN-40NST-40NPT-BB	2 1/2 - NST (NH)	
TFMHN-40NST-40NST-BB	2 1/2 - NST (NH)	2 1/2 - NST (NH)
TFMHN-40NPT-40NST-BB	2 1/2 - NPT	
TFMHN-48NST-40NST-BB	3 - NST (NH)	
TFMHN-48NPT-40NST-BB	3 - NPT	
TFMHN-40NPSH-40NST-BB	2 1/2 - NPSH	
TFMHN-40NPT-40NPT-BB	2 1/2 - NPT	
TFMHN-40NST-40NPSH-BB	2 1/2 - NST (NH)	2 1/2 - NPSH
TFMHN-40NPT-40NPSH-BB	2 1/2 - NPT	
TFMHN-40NST-48NPT-BB	2 1/2 - NST (NH)	3 - NPT
TFMHN-40NPT-48NPT-BB	2 1/2 - NPT	
TFMHN-48NST-48NPT-BB	3 - NST (NH)	
TFMHN-40NST-48NST-BB	2 1/2 - NST (NH)	3 - NST (NH)
TFMHN-40NPT-48NST-BB	2 1/2 - NPT	
TFMHN-48NPT-48NST-BB	3 - NPT	3 - NPSH
TFMHN-40NST-48NPSH-BB	2 1/2 NST (NH)	
TFMHN-40NST-64NPT-BB	2 1/2 - NST (NH)	4 - NPT
TFMHN-64NST-64NPT-BB	4 - NST (NH)	
TFMHN-72NST-64NPT-BB	4 1/2 - NST (NH)	4 - NST (NH)
TFMHN-64NPT-64NST-BB	4 - NPT	
TFMHN-64NPT-72NST-BB	4 - NPT	4 1/2 - NST (NH)
TFMHN-96NST-96NPT-BB	6 - NST (NH)	6 - NPT
TFMHN-96NPT-96NST-BB	6 - NPT	6 - NST (NH)

Thorburn Series TMMHN Male to Male Hex Nipples

Style TMMHN | Hex Nipples
- Male to Male (Code 23)



Thorburn Part #	Male Thread	Female Thread
TMMHN-24NPSH-12NPT-BB	1 1/2 - NPSH	3/4 - NPT
TMMHN-24NST-12NPT-BB	1 1/2 - NST (NH)	
TMMHN-12GHT-16NPT-BB	3/4 - GHT	1 - NPT
TMMHN-16NPSH-16NPT-BB	1 - NPSH	
TMMHN-16NST-16NPT-BB	1 - NST (NH)	
TMMHN-24NPSH-16NPT-BB	1 1/2 - NPSH	
TMMHN-24NST-16NPT-BB	1 1/2 - NST (NH)	
TMMHN-40NST-16NPT-BB	2 1/2 - NST (NH)	
TMMHN-24NPSH-24NPSH-BB	1 1/2 - NPSH	1 1/2 - NPSH
TMMHN-16NPSH-24NPT-BB	1 - NPSH	1 1/2 - NPT
TMMHN-16NST-24NPT-BB	1 - NST (NH)	
TMMHN-24NPSH-24NPT-BB	1 1/2 - NPSH	
TMMHN-24NPT-24NPT-BB	1 1/2 - NPT	
TMMHN-24NST-24NPT-BB	1 1/2 - NST (NH)	
TMMHN-32NPSH-24NPT-BB	2 - NPSH	
TMMHN-40NST-24NPT-BB	2 1/2 - NST (NH)	1 1/2 - NST (NH)
TMMHN-24NPSH-24NST-BB	1 1/2 - NPSH	
TMMHN-24NST-24NST-BB	1 1/2 - NST (NH)	
TMMHN-40NST-24NST-BB	2 1/2 - NST (NH)	
TMMHN-24NPSH-32NPT-BB	1 1/2 - NPSH	
TMMHN-24NST-32NPT-BB	1 1/2 - NST (NH)	
TMMHN-32NPSH-32NPT-BB	2 - NPSH	2 - NPT
TMMHN-40NPSH-32NPT-BB	2 1/2 - NPSH	
TMMHN-32NPT-32NPT-BB	2 - NPT	
TMMHN-40NST-32NPT-BB	2 1/2 - NST (NH)	
TMMHN-24NPSH-32NPT-BB	1 1/2 - NPSH	
TMMHN-24NST-32NPT-BB	1 1/2 - NST (NH)	
TMMHN-32NPSH-40NPT-BB	2 - NPSH	2 1/2 - NPT
TMMHN-40NPSH-40NPT-BB	2 1/2 - NPSH	
TMMHN-40NST-40NPT-BB	2 1/2 - NST (NH)	
TMMHN-40NPT-40NPT-BB	2 1/2 - NPT	
TMMHN-48NPSH-40NPT-BB	3 - NPSH	
TMMHN-48NPT-40NPT-BB	3 - NPT	
TMMHN-48NST-40NPT-BB	3 - NST (NH)	2 1/2 - NST (NH)
TMMHN-40NST-40NST-BB	2 1/2 - NST (NH)	
TMMHN-48NST-40NST-BB	3 - NST (NH)	
TMMHN-40NPSH-48NPT-BB	2 1/2 - NPSH	
TMMHN-40NST-48NPT-BB	2 1/2 - NST (NH)	
TMMHN-48NPSH-48NPT-BB	3 - NPSH	
TMMHN-48NST-48NPT-BB	3 - NST (NH)	3 - NPT
TMMHN-48NPT-48NPT-BB	3 - NPT	
TMMHN-64NPSH-64NPT-BB	4 - NPSH	
TMMHN-64NST-64NST-BB	4 - NST (NH)	
TMMHN-64NST-64NPT-BB	4 - NST (NH)	
TMMHN-72NST-64NPT-BB	4 1/2 - NST (NH)	
TMMHN-64NPT-64NPT-BB	4 - NPT	4 - NPT
TMMHN-80NST-80NPT-BB	5 - NST (NH)	
TMMHN-72NST-96NPT-BB	4 1/2 - NST (NH)	
TMMHN-96NST-96NPT-BB	6 - NST (NH)	
TMMHN-96NPSH-96NPT-BB	6 - NPSH	
TMMHN-96NPT-96NPT-BB	6 - NPT	

Thorburn Series TCGA Cam & Groove NST Adapters

Style TCGA | Camlock Adapter - Type A
with Female NST (NH) Adapter - Aluminum (Code 24)



Part Number	Size		Female NST (NH) Thread
	in	mm	in
TCGA-24-24NST-AL	1 1/2	38	1 1/2
TCGA-40-40NST-AL	2 1/2	64	2 1/2
TCGA-48-40NST-AL	3	76	2 1/2

Style TCGB | Camlock Coupler - Type B
with Male NST (NH) Adapter - Aluminum (Code 25)



Part Number	Size		Female NST (NH) Thread
	in	mm	in
TCGB-24-24NST-AL	1 1/2	38	1 1/2
TCGB-32-40NST-AL	2	25	1 1/2
TCGB-40-40NST-AL	2 1/2	64	2 1/2
TCGB-48-40NST-AL	3	76	2 1/2

Style TCGD | Female Camlock Coupler - Type D
with Female NST (NH) Adapter - Aluminum (Code 26)



Part Number	Size		Female NST (NH) Thread
	in	mm	in
TCGD-24-24NST-AL	1 1/2	38	1 1/2
TCGD-32-40NST-AL	2	25	2 1/2
TCGD-40-40NST-AL	2 1/2	64	2 1/2
TCGD-48-40NST-AL	3	76	2 1/2

Style TCGF | Camlock Adapter - Type F
with Male NST (NH) Adapter - Aluminum (Code 27)



Part Number	Size		Female NST (NH) Thread
	in	mm	in
TCGD-24-24NST-AL	1 1/2	38	1 1/2
TCGD-32-40NST-AL	2	25	2 1/2
TCGD-40-40NST-AL	2 1/2	64	2 1/2
TCGD-48-40NST-AL	3	76	2 1/2

Thorburn Series TMMA Male to Male Adapters - Pin Lug

Style TMMA | Adapter
- Male to Male - Pin Lug (Code 28)



Thorburn Part #	Male Thread	Male Thread
TMMA-24NST-24NST-BB	1 1/2 - NST (NH)	1 1/2 - NST (NH)
TMMA-24NPT-24NST-BB	1 1/2 - NPT	
TMMA-24NPSH-24NPSH-BB	1 1/2 - NPSH	1 1/2 - NPSH
TMMA-24NPT-24NPSH-BB	1 1/2 - NPT	
TMMA-24NPSH-24NST-BB	1 1/2 - NPSH	1 1/2 - NST (NH)
TMMA-40NST-40NST-BB	2 1/2 - NST (NH)	2 1/2 - NST (NH)
TMMA-40NPSH-40NST-BB	2 1/2 - NPSH	
TMMA-40NPT-40NST-BB	2 1/2 - NPT	
TMMA-40NPSH-40NPSH-BB	2 1/2 - NPSH	2 1/2 - NPSH

Thorburn Series TFSMA Female Swivel to Male Adapters - Pin Lug

Style TFSMA | Adapter
- Female Swivel to Male - Pin Lug (Code 29)



Thorburn Part #	Male Thread	Male Thread
TFSMA-24NST-24NPT-BB	1 1/2 - NST (NH)	1 1/2 - NPT
TFSMA-40NST-24NPT-BB	2 1/2 - NST (NH)	1 1/2 - NPT
TFSMA-40NST-32NPT-BB	2 1/2 - NST (NH)	2 - NPT
TFSMA-40NST-40NPT-BB	2 1/2 - NST (NH)	2 1/2 - NPT
TFSMA-40NST-48NPT-BB	2 1/2 - NST (NH)	3 - NPT
TFSMA-64NST-64NPT-BB	4 - NST (NH)	4 - NPT
TFSMA-24NPSH-24NPT-BB	1 1/2 - NPSH	1 1/2 - NPT
TFSMA-32NPSH-32NPT-BB	2 - NPSH	2 - NPT
TFSMA-40NPSH-40NPT-BB	2 1/2 - NPSH	2 1/2 - NPT
TFSMA-24NPSH-24NST-BB	1 1/2 - NPSH	1 1/2 - NST (NH)
TFSMA-40NST-48NST-BB	2 1/2 - NST (NH)	3 - NST (NH)

Thorburn Series TCH Camlock Hydrant Adapters - Pin Lug

**Style TCH | Camlock Hydrant Adapter
- Male to Female - Pin Lug (Code 30)**



Thorburn Part #		Male Adapter	Female Thread
Brass	Aluminum	in	in
TCH-24-NST-BB	TCH-AL	1 1/2	1 1/2 - NST (NH)
TCH-40-NST-BB	TCH-AL	2 1/2	2 1/2 - NST (NH)

Style TCHG | Replacement Gasket



Thorburn Part #	ID	OD	Thickness
Buna - N	in	in	in
TCHG-25	1 9/16	2 1/16	1/8
TCHG-41	2 9/16	3 1/16	3/16

Thorburn Series TBC Brass Caps - Pin Lug

**Style TBC | Brass Cap - Pin Lug
(Code 31)**



Thorburn Part #	Thread
	in
TCB-24-NST-BB	1 1/2 - NST (NH)
TCB-32-NST-BB	2 - NST (NH)
TCB-40-NST-BB	2 1/2 - NST (NH)
TCB-48-NST-BB	3 - NST (NH)
TCB-64-NST-BB	4 - NST (NH)
TCB-72-NST-BB	4 1/2 - NST (NH)
TCB-96-NST-BB	6 - NST (NH)
TCB-24-NPSH-BB	1 1/2 - NPSH
TCB-32-NPSH-BB	2 - NPSH
TCB-40-NPSH-BB	2 1/2 - NPSH
TCB-48-NPSH-BB	3 - NPSH
TCB-64-NPSH-BB	4 - NPSH
TCB-80-NPSH-BB	5 - NPSH

Thorburn Fire Hose Nozzles



How To Order Thorburn Layflat and Fire Hose

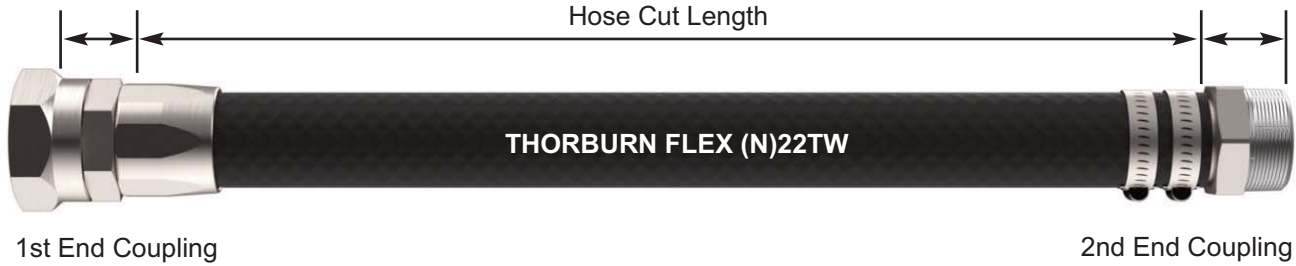

Model	1st End Coupling	1st End Clamp or Ferrule	2nd End Coupling	2nd End Clamp or Ferrule	Hose Length (in)	Options/Accessories
(N)22TW	01	V	02C	D2	600	19
<p>(N)22TW Pg 137</p> <p>(N)22TWB Pg 138</p> <p>(N)223TW Pg 139</p> <p>(N)224TW Pg 140</p> <p>(N)225TW Pg 140</p>	<p>Shank Couplings - Low Pressure</p> <p>901 = Male NPT Pg 60</p> <p>902 = Stub End for Floating Flanges Pg 60</p> <p>903 = Victaulic Grooved End Pg 61</p> <p>904 = Welded End Pg 61</p> <p>905 = Hose Mender Pg 61</p> <p>Thorburn TB Bauer Type B Style Lever Couplings</p> <p>1201 = Male Hose Shank Pg 74</p> <p>1202 = Female Hose Shank Pg 74</p> <p>1203 = Male Socket with Male NPT Pg 75</p> <p>1204 = Female Plug with Male NPT Pg 75</p> <p>1205 = Male Socket with 150 ASA Flange Pg 75</p> <p>1206 = Female Socket with 150 ASA Flange Pg 76</p> <p>1207 = Female Plug with Gasket Pg 76</p> <p>1208 = Lever Ring Pg 76</p> <p>Thorburn TP Perrot Type C Style Lever Couplings</p> <p>1301 = Female Socket with Hose Stem Pg 78</p> <p>1302 = Male Plug with Hose Stem Pg 78</p> <p>1303 = Female Socket with Male NPT Pg 79</p> <p>1304 = Male Plug with Male NPT Pg 79</p> <p>1305 = Female Socket with 150 ASA Flange Pg 79</p> <p>1306 = Male Plug with 150 ASA Flange Pg 80</p> <p>1307 = Female End Cap Pg 80</p> <p>1308 = Male End Cap Pg 80</p> <p>1309 = Lever Ring Pg 81</p> <p>HOSE SHANKS</p> <p>01 = Female Camlock Coupler Type C Pg 141</p> <p>02 = Male Camlock Adapter Type C Pg 142</p> <p>03 = Female MPSM Pin Lug Pg 142</p> <p>04 = Male MPSM Pin Lug Pg 142</p> <p>FHS (Storz Type) FIRE HOSE COUPLINGS</p> <p>05 = SHS Hose Shank Complete Pg 143</p> <p>ADAPTERS</p> <p>05A = SMA Male BSPP Pg 143</p> <p>05B = SFA Female BSPP Pg 144</p> <p>05C = SBC Blank Cap with Chain Pg 144</p> <p>INSTANTANEOUS COUPLINGS</p> <p>06 = TIC-FHS-MHS Male/Female Hose Stem Pg 145</p> <p>07 = TIC-FHS Female Hose Stem Pg 145</p> <p>08 = TIC-MHS Male Hose Stem Pg 146</p> <p>ADAPTERS</p> <p>09 = TIC-FFT Female X Female Threads Pg 146</p> <p>10 = TIC-FMT Female X Male Threads Pg 146</p> <p>11 = TIC-MFT Male X Female Threads Pg 147</p> <p>12 = TIC-MMT Male X Male Threads Pg 147</p> <p>13 = TIC-MMA Male X Male Adapter Pg 147</p> <p>14 = TIC-FFA Female X Female Adapter Pg 148</p> <p>15 = TIC-P Plug Pg 148</p> <p>16 = TIC-C Cap Pg 148</p>				<p>For metric lengths use (mm) at end of the part #</p>	<p>FIRE HOSE ADAPTERS TO FIRE HYDRANT</p> <p>19 = TFSA Swivel Adapters - Pin Lug Pg 151</p> <p>20 = TFSA-D Female Swivel Adapter - Double Pin Lug Pg 151</p> <p>21 = THA Hydrant Adapters - Pin Lug Pg 152</p> <p>22 = TFMHN Female to Male Hex Nipples Pg 153</p> <p>23 = TMMHN Male to Male Hex Nipples Pg 154</p> <p>24 = TCGA Camlock Adapter - Type A Pg 155</p> <p>25 = TCGB Camlock Coupler - Type B Pg 155</p> <p>26 = TCGD Female Camlock Coupler - Type D Pg 155</p> <p>27 = TCGF Camlock Adapter - Type F Pg 155</p> <p>28 = TMMA Male to Male Adapters - Pin Lug Pg 156</p> <p>29 = TFSMA Female Swivel to Male Adapters - Pin Lug Pg 156</p> <p>30 = TCH Camlock Hydrant Adapters - Pin Lug Pg 157</p> <p>31 = TBC Brass Caps - Pin Lug Pg 157</p> <p>NOZZLE ACCESSORIES</p> <p>32 = Plastic 1.5" NPSH Thread with 1/2" Orifice Tip Pg 158</p> <p>33 = Brass Nozzle 1.5" NPSH Thread - 3/8" Orifice Tip Pg 158</p> <p>34 = Comb. Fog Nozzle - Polycarbonate - 3/4" (8GPM) Pg 158</p> <p>35 = Comb. Fog Nozzle - Polycarbonate - 1" (22GPM) Pg 158</p> <p>36 = Comb. Fog Nozzle - Polycarbonate - 1 1/2" (75GPM) Pg 158</p> <p>37 = Comb. Fog Nozzle - Brass - 1 1/2" (75GPM) Pg 158</p> <p>38 = Comb. Fog Nozzle - Polycarbonate - 2" (150GPM) Pg 158</p> <p>39 = Comb. Fog Nozzle - Polycarbonate - 2 1/2" (150GPM) Pg 158</p> <p>EXPANSION RING COUPLINGS</p> <p>17 = TERCS Exp. Ring - Single Jacket* Pg 149</p> <p>18 = TERCS Exp. Ring - Double Jacket* Pg 149</p> <p>HOSE CLAMPS</p> <p>D = Style 65 C Preformed "Fast Lock" Clamp* Pg 100</p> <p>Quantity of Clamps (If 1 leave blank) 2, 3, 4 (Specify # after clamp code)</p> <p>CRIMP FERRULES</p> <p>S = Style TF - Notched (Plated Steel) Pg 108</p> <p>T = Style TFS - Notched (316SS) Pg 108</p> <p>U = Style TSS - Short Sleeve (Plated Steel) Pg 109</p> <p>V = Style TSSS - Short Sleeve (316SS) Pg 109</p> <p>W = Style TSL - Long Sleeve (Plated Steel) Pg 110</p> <p>X = Style TSLS - Long Sleeve (316SS) Pg 110</p> <p>OTHER</p> <p>Y = Specify</p>

* Choose Material: S6 = 316SS, CP = Plated Steel, BB = Brass, MI = Maleable Iron

Thorburn Series TBV - Ball Valves



Thorburn Series TBV Ball Valves: are made of 316 stainless steel or brass for rust protection and long service life that performs well after many cycles, and close securely even after long periods of disuse. Thorburn Ball Valves use a spherical disc to control the flow between pipes, tubes, or hoses and have minimal flow resistance.

Features:

- Sizes up to 2" rated 600 WOG
- Sizes 2 1/2" to 4" rated 400WOG
- Temperature range: Up to 80°C (175°F)
- Brass ball is chromium plated
- Ball seat is made of PTFE

Materials:

Valve Body: 316SS, Brass

Valve Cap: 316SS, Brass

O-Ring: PTFE

Ball: Brass - Chromium Plated

Stem Spacer/Gasket: PTFE

Stem: Brass



Thorburn Part #		Hose ID		Thread Size
316SS	Brass	in	mm	
TBV02-S6	TBV02-BB	1/4	6	1/4-18 NPT
TBV06-S6	TBV06-BB	3/8	10	3/8-18 NPT
TBV08-S6	TBV08-BB	1/2	13	1/2-14 NPT
TBV12-S6	TBV12-BB	3/4	19	3/4-14 NPT
TBV16-S6	TBV16-BB	1	25	1-11 1/2 NPT
TBV20-S6	TBV20-BB	1 1/4	32	1 1/4-11 1/2 NPT
TBV24-S6	TBV24-BB	1 1/2	38	1 1/2-11 1/2 NPT
TBV32-S6	TBV32-BB	2	51	2-11 1/2 NPT
TBV40-S6	TBV40-BB	2 1/2	64	2 1/2-8 NPT
TBV48-S6	TBV48-BB	3	76	3-8 NPT
TBV64-S6	TBV64-BB	4	102	4-8 NPT

Thorburn Series SPNM - Heavy Duty Spray Nozzle



Thorburn Part Number: SPNM-08

Thorburn Series SPNM: Stainless steel, heavy-duty spray nozzle delivers powerful wash-down performance in a compact, lightweight design. It features a 1/2" female NPT inlet and a removable nylon protective cover shields operators from hot surfaces produced by high temperature washdown applications, while the smooth lever action reduces hand fatigue during extended use. The adjustable spray pattern transitions easily from a wide fan to a solid stream, offering excellent versatility for industrial cleaning tasks. Designed for efficiency, the drip-free automatic shut-off activates the moment the lever is released, conserving water and keeping work areas clean. Ideal for demanding environments, the SPNM provides lightweight performance in a convenient, operator-friendly package.

Features:

- Compact stainless-steel construction for long-lasting durability in harsh environments.
- 1/2" Female NPT inlet provides a leak-free connection to standard washdown systems.
- Removable nylon protective cover shields operators from high-temperature applications.
- Smooth, low-effort lever action reduces operator fatigue during prolonged use.
- Adjustable spray pattern easily shifts from wide fan to solid stream.
- Drip-free automatic shut-off activates when the trigger is released.

Specifications:

Pressure Rating: 10 bar (150 PSI) at 93°C (200°F)

Flow Capacity: 9.6 GPM at 100 PSIG

Thorburn Series SPNL - Locking Spray Nozzle



Thorburn Part Number: SPNL-08

Thorburn Series PSNL: Stainless steel locking spray nozzle is lightweight and user friendly, engineered for maximum safety and reliability. It features a 1/2" female NPT inlet and a removable nylon protective cover that shields operators from hot surfaces produced by high temperature washdown applications. Its unique cover design prevents accidental activation if the nozzle is dropped, while the smooth, front-mounted lever minimizes hand fatigue during extended washdown use. A built-in trigger locking mechanism enables secure, continuous spraying at any setting. The adjustable spray pattern transitions easily from a wide fan to a solid stream, providing versatility for a wide range of cleaning applications. For efficiency and water savings, the drip-free automatic shut-off activates instantly when the lever is released, ensuring clean, controlled performance every time.

Features:

- Stainless steel construction for long-lasting durability and dependable performance.
- 1/2" Female NPT inlet for a leak-free connection to standard washdown systems.
- Removable nylon protective cover shields operators from high-temperature applications.
- Cover design prevents accidental activation if the nozzle is dropped.
- Trigger locking mechanism enables continuous spray operation.
- Adjustable spray pattern from wide fan to solid stream with automatic shut-off.

Specifications:

Pressure Rating: 10 bar (150 PSI) at 93°C (200°F)

Flow Capacity: 9.6 GPM at 100 PSIG

Thorburn Foot Valves for Water Suction Hose



Thorburn Foot Valves are used on the submersed end of a suction hose to prevent objects or debris of a certain size from entering the hose and to prevent the pump from losing its prime when shut down. Each valve has a built in strainer and has NPS threads for all sizes. Made of plated steel and also available in black PVC.

Thorburn Part #		Hose ID	
Plated Steel	PVC	in	mm
TFV24-CP	TFV24-P	1 1/2	38
TFV32-CP	TFV32-P	2	51
TFV40-CP	TFV40-P	2 1/2	64
TFV48-CP	TFV48-P	3	76
TFV64-CP	TFV64-P	4	102
TFV96-CP	TFV96-P	6	152
TFV128-CP	TFV128-P	8	203

Thorburn Strainers for Water Suction Hose

Thorburn Strainers are used on the submersed end of a suction hose to prevent debris from entering the pump during operation. Threads are NPS for all types. Made of galvanized plated steel.



Round Hole



Square Hole



Tube



Top Hole



Bottom Hole

Thorburn Part #					Hose ID	
Round Hole	Square Hole	Tube	Top Hole	Bottom Hole	in	mm
TRHS24-CP	TSHS24-CP	TTS24-CP	TTHS24-CP	TBHS24-CP	1 1/2	38
TRHS32-CP	TSHS32-CP	TTS32-CP	TTHS32-CP	TBHS32-CP	2	51
TRHS40-CP	TSHS40-CP	TTS40-CP	TTHS40-CP	TBHS40-CP	2 1/2	64
TRHS48-CP	TSHS48-CP	TTS48-CP	TTHS48-CP	TBHS48-CP	3	76
TRHS64-CP	TSHS64-CP	TTS64-CP	TTHS64-CP	TBHS64-CP	4	102
TRHS96-CP	TSHS96-CP	TTS96-CP	TTHS96-CP	TBHS96-CP	6	152
TRHS128-CP	TSHS128-CP	TTS128-CP	TTHS128-CP	TBHS128-CP	8	203

Thorburn Conical Strainers



Thorburn Conical Strainers are devices for mechanically removing unwanted solids from liquid, gas or steam lines by means of a perforated or wire mesh straining element. They are used in pipelines to protect pumps, meters, control valves, steam traps, regulators, and other process equipment. Conical Strainers are used in a wide variety of liquid straining applications to protect downstream process system components in many industries, including chemical processing, petroleum, power generation and marine. Made of 304 stainless steel and gasket made of nitrile compound.

Thorburn Part #	Hose ID	
	in	mm
TSCS32-S4	2	51
TSCS48-S4	3	76
TSCS64-S4	4	102

Thorburn Pump Plate Strainers



Thorburn Pump Plate Strainers are made to thread into a Thorburn Part "A" or a Part "D" cam and groove fitting and is used to protect pumps from large contaminants. The strainer is made of 0.20" thick aluminum and the holes are 1/4". Threads are NPT.

Thorburn Part #	Hose ID	
	in	mm
TPPS24-AL	1.5	38
TPPS32-AL	2	51
TPPS48-AL	3	76
TPPS64-AL	4	102

Thorburn Hydro-Air Pressure Washer



Thorburn Part Number (Complete Kit) : TDM2000R

Thorburn's Hydro-Air Pressure Washer uses approximately 4 cu. ft. of air per minute, and less than 4 gallons of water per minute at 50 lbs water pressure. Recommended air pressure for simple cleaning: 75 lbs or more. When heavier blasting forces are needed use 150 to 200 lbs. Air connection is Standard 1/4" pipe thread and water connection is garden hose thread. For best results, use 3/4" water line and 1/2" air line. Complete rubber seal replacement kit is available.

Contents of kit: Washer, siphoning attachment, nozzle extensions, flushing adapter, garden hose quick coupler, rubber grips.

Thorburn Hydro-Blast Cleaning Tool and Siphon



Thorburn Part Number: TD230

Thorburn Hydro-Blast Cleaning Tool and Siphon combines compressed air and water pressure to blast away dirt and grime. This powerful and versatile cleaning tool:

- Uses siphon to spray solvent or detergent solutions
- Uses regular garden hose plus compressed air to blast off dirt and residue
- Can be used with hot or cold water. Valve body stays cool even when used with hot water
- Used in garages and factories to blast caked-on dirt from vehicles and equipment

Contents of kit: Valve body, 2" and 15" extensions, six foot siphon tubing and adapter for garden hose.

NOTE: The tubing supplied is vinyl and the internal seals in the valve body are Buna-N. Consult chemical resistance charts for compatibility of solvents before putting gun into solvent service.

Thorburn Strata-Flow Blow Gun



Thorburn Part Number: TD212

Thorburn's Strata-Flow Blow Gun works when compressed air moving over the Strata-Flo nozzle cone "captures" free air and concentrates it into a powerful stream. There is no hole through the Strata-Flo nozzle, so dead-ending it can not cause a dangerous pressure buildup. The Strata-Flo consumes only 6 cfm of air at 100 psi. Because the high velocity air stream is less turbulent, Thorburn's Strata-Flow is much quieter than ordinary blow guns – far below any existing noise level standards. Safety glasses or shield must be worn when using any blow gun.

NOTE: Strata-Flo blow guns have a safety tip which prevents buildup of tip pressure in the event the outlet is obstructed or "dead ended". It complies with the requirements of OSHA 1910.242lb and 191095 when used on air lines of 150 psi or less.

Thorburn Hose Assembly Whip Checks

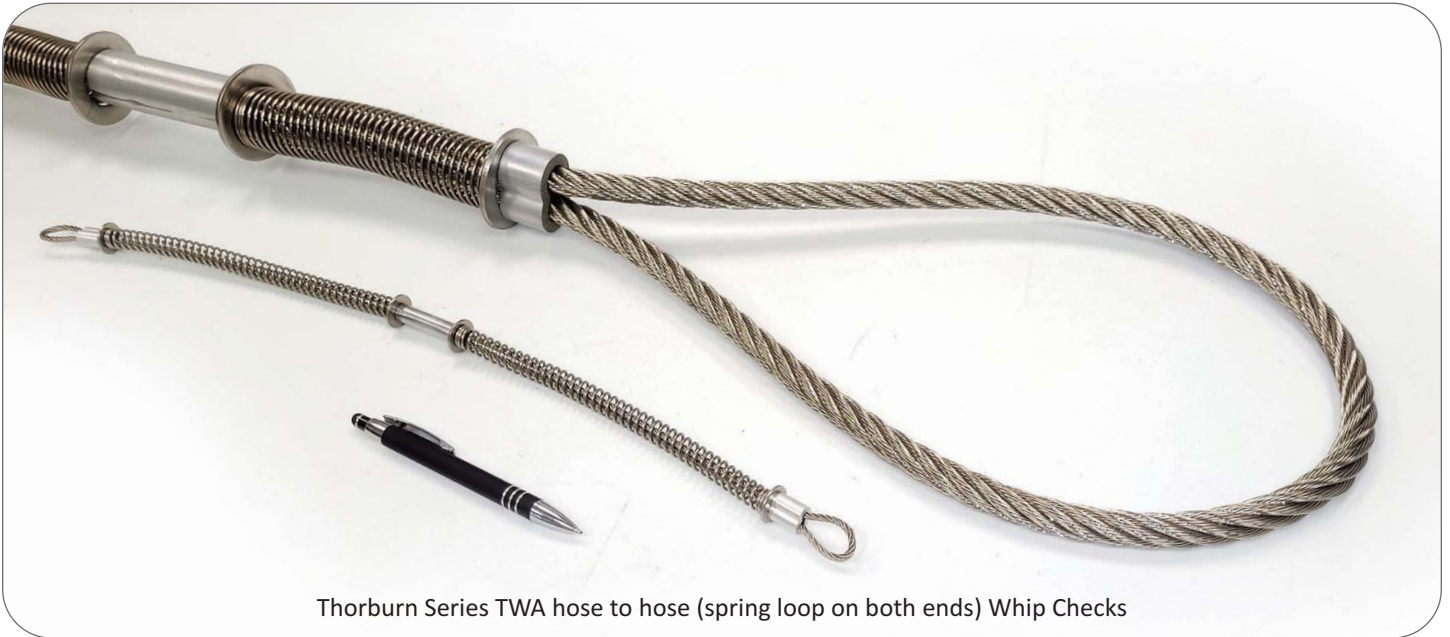

Thorburn Series TWA hose to hose (spring loop on both ends) Whip Checks



Thorburn Series TWA hose to hose whip check

Warning: Replace and discard if a blowout event occurs. Always install fully extended with no slack, with the cable centered on the hose connection when possible.

Thorburn Whip Checks are designed to give protection from hose whipping if a hose disconnects under high pressure. Thorburn Whip Checks are an easy to use safety product to prevent injury and are highly resistant to rust and corrosion. Thorburn Whip Checks do not require any tools to install having spring-loaded loops in the cable ends to easily pass over the couplings, for a firm grip on the hose. Highly recommended for high pressure applications.

Features:

- Sizes for a range from 1/2" through 10" hose diameters
- 200 PSI air service rating
- 5X safety ratio (1000 PSI burst)
- Galvanized Steel or 304 Stainless Steel
- Available as hose-to-hose or hose-to-tool styles



Thorburn's Series TWSR is designed for one side of the whip check to loop over a pneumatic tool such as the neck of a jackhammer and the other spring end to loop around the hose.

Thorburn Hose Assembly Whip Check Specifications

Thorburn Series TWB/TWA Hose To Hose Whip Check

Thorburn Part Number		Hose Size	Length (L)		Cable OD (A)		Approximate Break Strength	Weight
SS304	Galvanized	in	in	mm	in	mm	KN	kg/pc
TWB1-S4	TWB1-CP	1/2" - 1 1/4"	20.25	514.3	1/8"	3.0	6.5	0.11
TWA2-S4	TWA2-CP	1 1/2" - 3"	38	965.2	1/4"	6.0	27.5	0.45
TWA4-S4	TWA4-CP	4"	44	1117.6	3/8"	9.5	38.2	1.15
TWA6-S4	TWA6-CP	6"	43.5	1100	3/8"	9.5	85.5	1.20
TWA8-S4	TWA8-CP	8"	55	1400	9/16"	14.0	150	2.86

1. Wire Rope
2. Slider
3. Flat Washer
4. Ferrules
5. Spring

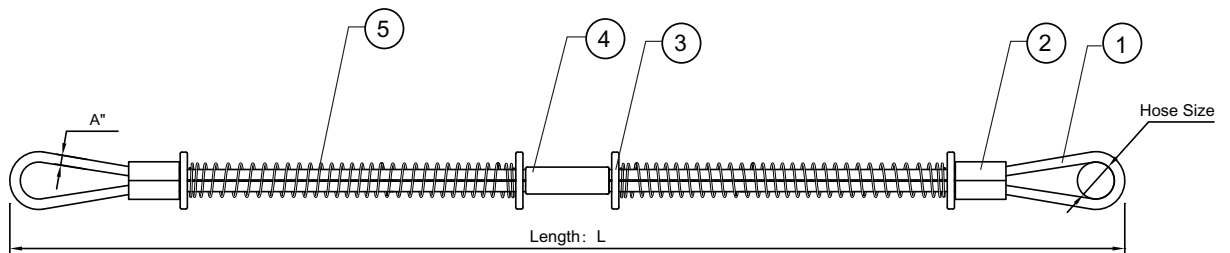

Thorburn Series TWSR Hose To Tool Whip Check

Thorburn Part Number		Hose Size	Length (L)		Cable OD (A)		Approximate Break Strength	Weight
SS304	Galvanized	in	in	mm	in	mm	KN	kg/pc
TWSR1-S4	TWSR1-CP	1/2" - 1 1/4"	20.25	514.3	1/8"	3.0	6.5	0.07
TWSR2-S4	TWSR2-CP	1 1/2" - 3"	38	965.2	1/4"	6.0	27.5	0.37
TWSR4-S4	TWSR4-CP	4"	44	1117.6	3/8"	9.5	37.2	1.00
TWSR6-S4	TWSR6-CP	6"	43.5	1100	3/8"	9.5	85.5	1.05
TWSR8-S4	TWSR8-CP	8"	55	1400	9/16"	14.0	150	2.68

1. Wire Rope
2. Slider
3. Flat Washer
4. Ferrules
5. Spring

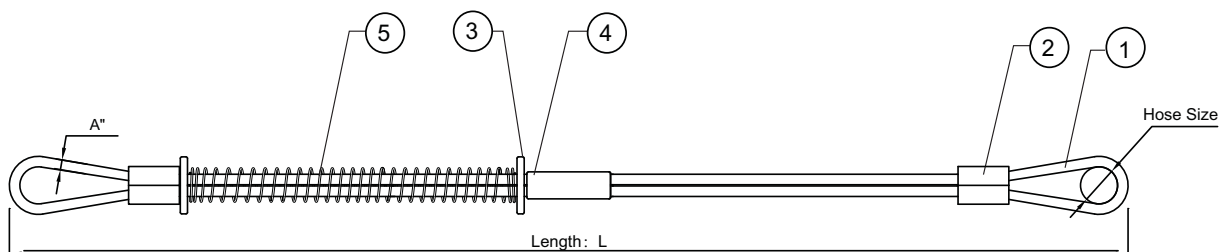

Thorburn Series TWS Hose Assembly Whip Socks



Thorburn's Whip Sock high pressure hose restraints are designed to significantly reduce the risk of injury caused by a high pressure hose blow-out failure. The magnitude of force caused by a large-diameter pressurized hose can cause fatal injury and be difficult to quickly restrain. Thorburn Whip Socks also provide a grip on a hose over the larger area so to securing the hose and prevent it from whipping if a high-pressure accident causes the hose to release from its place. The double leg loop ends will also prevent the hose from side to side whipping under pressure. Whip Socks are Ideal for use in hydraulic systems or to restrain high pressure hoses dispensing water, air, sand, steam, concrete and slurry. Thorburn Whip Sock systems are capable of significantly higher pressure ratings than the standard Whip Check or nylon hose safety restraints and can also be connected directly to one another without a clamp where two hoses are being joined. Each restraint features thimble eyes that are used as shackle points when fitted over the hose.



Features:

- Sizes for a range from 1/2" through 6" hose diameters
- Keeps personnel and equipment safe
- Minimizes the high-pressure hose whipping
- Protects hoses from abrasion and wear
- 15" long leads for easier and more flexible installation
- Galvanized or 304 stainless steel

Thorburn Series TWS Hose Assembly Whip Sock Specifications

Thorburn Part Number		Hose Size	Dimension (B)		Dimension (R)				Dimension (M)		Approx. Break Strength
					Min		Max				
SS304	Galvanized Steel	in	in	mm	in	mm	in	mm	in	mm	KN
TWS08-S4	TWS08-CP	1/2"	5.9	150	0.75	19	1.10	28	19.69	500	38
TWS12-S4	TWS12-CP	3/4"	7.1	180	1.10	28	1.57	40	23.62	600	57
TWS16-S4	TWS16-CP	1"	7.1	180	1.57	40	1.97	50	31.50	800	57
TWS24-S4	TWS24-CP	1 1/2"	9.8	250	1.97	50	2.36	60	35.43	900	100
TWS32-S4	TWS32-CP	2"	10.0	254	2.36	60	2.76	70	35.43	900	100
TWS40-S4	TWS40-CP	2 1/2"	10.6	270	2.76	70	3.35	85	39.37	1000	100
TWS48-S4	TWS48-CP	3"	15.0	381	3.35	85	3.94	100	39.37	1000	158
TWS56-S4	TWS56-CP	3 1/2"	16.5	420	3.94	100	4.72	120	47.24	1200	158
TWS64-S4	TWS64-CP	4"	23.6	600	4.72	120	5.91	150	55.12	1400	195
TWS96-S4	TWS96-CP	6"	23.6	600	5.91	150	7.48	190	63.00	1600	195
TWS128-S4	TWS128-CP	8"	23.6	600	7.51	191	8.66	220	63.00	1600	195

1. Wire Mesh Assembly
2. Shoulder Protector
3. Aluminum Sleeve
4. Capel
5. Wire Rope

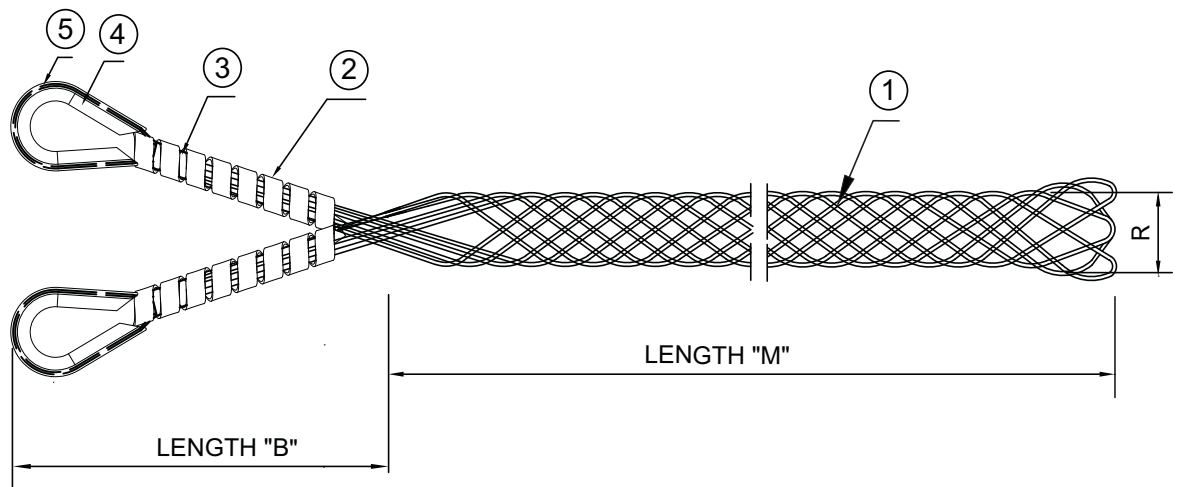

Warning: When installing a Whip Stop Safety Restraint, ensure proper fit by verifying if the diamond-pattern of the braiding is equally proportioned. If the diamonds are longer than they are wide, then the restraint is too big and the hose is at risk of slipping. After installing on the hose, pull on the loop ends to ensure there is no movement or rotation of the hose. Inspect Whip Sock restraints regularly, and replace if there is any sign of rust or broken cable strands.

Thorburn THOR-REEL - Heavy Duty High Pressure Hose Reels

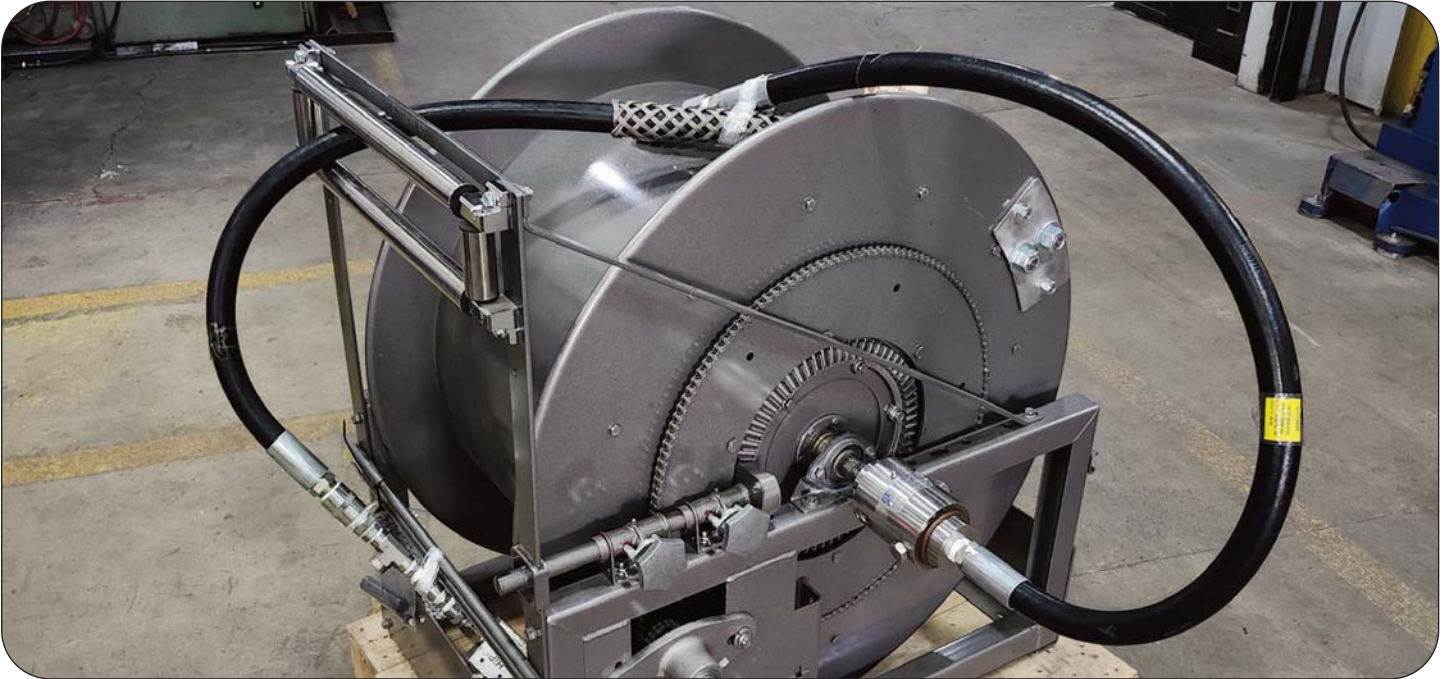

Whip Check added for safety

THOR-REEL™ Hose Reels

Air, Water, Lube Oil & Waste Oil Evacuation Applications

THOR-REEL™ Features & Benefits:

- Rugged assembly for heavy-duty applications
- Non sparking ratchet assembly
- Constant Tension is available – *Consult Thorburn for details*
- Arbor disengagement to prevent damage from reverse winding
- Standard material is carbon steel – *Also available in other materials*
- Pressure up to 20,000 psi (1379 bar) also available – *Consult Thorburn for details*
- Sprocket drive powered by an electric, hydraulic or compressed air motor with a strap brake. (Gear driven & crank rewind also available).
- Standard inlet, outlet riser, and hub assembly are steel.
- Riser and hub assembly also available in stainless steel.



All wetted parts made from Duplex 2205 material including piping and live swivel joint

Thorburn THOR-REEL - Heavy Duty High Pressure Hose Reels



Thorburn's THR2 Heavy Duty Large Frame Spring Rewind Hose Reel

Spring Rewind Hose Reels

Hose ID Sizes: 1/2" (13 mm) through 1 1/2" (38 mm)
Pressures up to 3,000 PSI (207 BAR)

Model THR1 (Light Duty): **Hose ID:** From 1/2" through 1" I.D.
Inlet: 1/2" up to 1" female/male NPT 90° swivel joint.
Swivel Joint: 1/2" up to 1" female/male NPT. **Pressure:** up to 3000 psi (207 bar)
Temperature: -54°C (-50°F) to 100°C (212°F)

Model THR2 (Heavy Duty): **Hose ID:** From 1/2" through 1" I.D.
Inlet: 1/2" up to 1" female/male NPT 90° swivel joint.
Swivel Joint: 1/2" up to 1" female/male NPT. **Pressure:** up to 3000 psi (207 bar)
Temperature: -54°C (-50°F) to 100°C (212°F)

Model THR3 (Heavy Duty): **Hose ID:** From 1" through 1 1/2" I.D.
Inlet: 1" up to 1 1/2" female/male NPT 90° swivel joint.
Swivel Joint: 1" to 1 1/2" female/male NPT. **Pressure:** up to 600 psi (41 bar)
Temperature: -54°C (-50°F) to 100°C (212°F)

NOTE: Other sizes and/or threads can be furnished for swivel joint when specified. Reels to operate at other temperatures or pressures are available.

Power Rewind Hose Reels

Hose ID Sizes: 1/2" (13 mm) through 3" (80 mm)
Pressures up to 20,000 PSI (1379 BAR)

Model THR5 (Heavy Duty): **Hose ID:** From 1/2" through 2" I.D.
Inlet: 1/2" up to 2" female NPT 90° swivel joint.
Swivel Joint: 1/2" up to 2" female NPT. **Pressure:** up to 20,000 psi (1379 bar)
 (For higher pressure, consult thorburn for thread configuration)
Temperature: -51°C (-60°F) to 121°C (250°F)

Model THR6 (Heavy Duty): **Hose ID:** From 1/2" through 1" I.D.
Inlet: 1/2" up to 1" female/male NPT 90° swivel joint.
Swivel Joint: 1/2" up to 1" female/male NPT. **Pressure:** up to 5,000 psi (345 bar)
Temperature: -51°C (-60°F) to 121°C (250°F)

Model THR7 (Heavy Duty): **Hose ID:** From 1" through 1 1/2" I.D.
Inlet: 1" up to 1 1/2" female/male NPT 90° swivel joint.
Swivel Joint: 1" up to 1 1/2" female/male NPT. **Pressure:** up to 600 psi (41 bar)
Temperature: -51°C (-60°F) to 121°C (250°F)

Model THR9 (Heavy Duty): **Hose ID:** From 2" through 3"
Inlet: 2" up to 3" female/male NPT 90° swivel joint.
Swivel Joint: 2" to 3" female/male NPT. **Pressures:** up to 300 psi
Temperature: -51°C (-60°F) to 121°C (250°F)

NOTE: A flexible connector must be used between the inlet pipe and the inlet swivel joint. Some applications require a clutch/ reduction unit.



Thorburn's THR5 Heavy Duty Large Frame Power Rewind Hose Reel

THOR-REEL™ Technical Data

Thorburn Part Number	Hose Capacity of Reel									Appr. Weight Crank Rewind	
	ID in	1/2	3/4	1	1 1/4	1 1/2	2	2 1/2	3	NET lb	SHIP lb
	ID mm	13	19	25	32	38	51	64	76		
OD in	7/8	1-9/32	1-9/16	1-13/16	2-1/16	2-9/16	3-3/16	3-3/4	OD mm	kg	kg
Spring Rewind Hose Reels											
THR1-23-6	ft m	100 30	65 20	60 18						95 43	145 66
THR2-31-10	ft m	90 27	100 30	100 30						128 58	178 80
THR3-31-8	ft m			75 23	75 23	50 15				125 57	168 76
Power Rewind Hose Reels											
THR6-30-31	ft m	400 122	200 61	125 38						101 40	151 68
THR6-33-34	ft m		550 168	300 91						129 69	179 81
THR7-23-24	ft m			200 61	175 53	100 30				130 59	172 78
THR7-33-34	ft m			300 91	200 61	175 53				133 60	183 83
THR9-33-34	ft m						100 30	46 14	38 11	187 85	257 117
THR9-45-46	ft m						200 61	130 40	116 35	361 164	525 239

Notes:

- Specifications subject to change.
- Upon request, reels can be supplied with drum lengths other than shown and with disc sizes in other diameters.
- Dimensions shown for reels up to and including 30-31 disc size reflect pressed frames. All others are rollformed channel frames.
- Weights shown in chart are for crank rewind models. ADD these amounts for power rewind models.

Power Type	Net lbs/kg	Ship lbs/kg
Electric	40/18.1	40/18.1
Hydraulic	20/9.1	20/9.1
Air	20/9.1	20/9.1

- When ordering power rewind models, suffix model number with:
AR = Air Rewind – Supplied with control valve and 18" air hose.
ER = Electric Rewind (1/2 HP) – 12v and 24v DC rewind reels are supplied with switch and solenoid;
ER115V = 115v AC rewind reels are not supplied with switch but can be ordered separately.
HR = Hydraulic Rewind – Not supplied with control valve.
- Roller position add suffix code after power code.
TW (Top Wind - Right Hand Inlet)
BW (Bottom Wind - Right Hand Inlet)
SW (Side Wind - Left Hand Inlet)
- Optional rubber hose stopper add suffix code **S** after roller position

Roller Position: A suffix code must be added after the model number to specify desired position. Reels are shipped in the BW position unless specified otherwise.

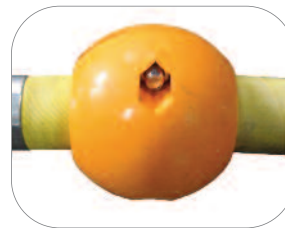
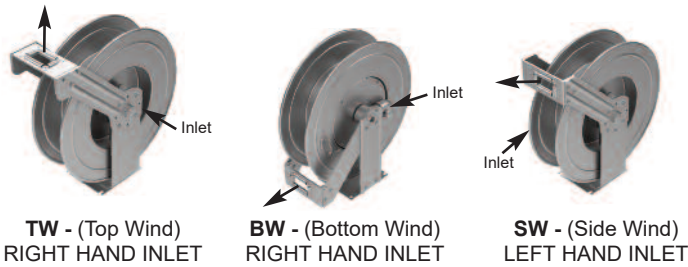

Included

Rubber Hose Stopper:

hose stoppers should be used to prevent damage to rollers and nozzles and to permit adjustment of free hose length and a non-slip grip.

How To Order Thorburn THOR-REEL™

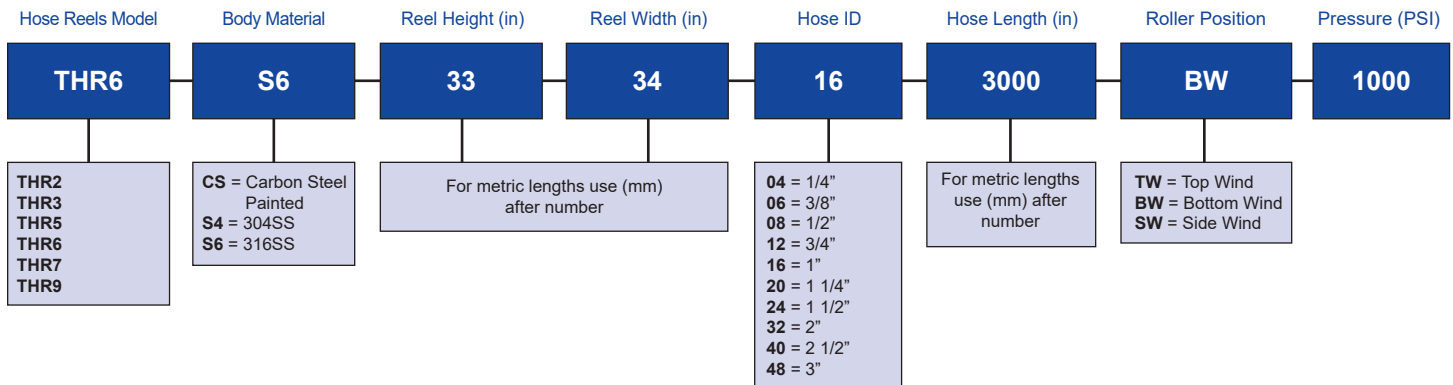

Thorburn THOR-REEL™ Series THR Utility Hose Reels



Thorburn's THRS4 Stainless Steel Spring Rewind Hose Reel

Thorburn Series THR utility hose reels are engineered for dependable handling of air, water, hydraulic fluids, and grease, delivering efficient, long-lasting hose management across demanding industries. A fully enclosed drive spring shields internal components from contaminants, ensuring smooth, consistent retraction with minimal maintenance. For enhanced safety, the reel features an adjustable cushion stop to lock the hose at the desired length, while multi-position guide arms allow flexible installation on walls, ceilings, floors, or service vehicles. By reducing hose wear, minimizing trip hazards, and keeping workspaces organized, Thorburn's THR hose reels improve overall productivity and safety.

Thorburn THRS4 – Stainless Steel (Sanitary & Hygienic Environments)

Constructed from premium SS 304 stainless steel with an advanced electrochemical finish, Thorburn's THRS4 is purpose-built for clean and sanitary applications. It offers exceptional corrosion resistance, durability, and a smooth, hygienic surface that withstands frequent washdowns and high-moisture conditions. Ideal for food & beverage processing, pharmaceutical facilities, and other hygiene-critical indoor environments.



Thorburn's THRC5 Coated Carbon Steel Spring Rewind Hose Reel

Thorburn THRC5 – Carbon Steel (Extreme Duty Outdoor Performance)

Constructed from high-tensile carbon steel, Thorburn's THRC5 is purpose-built for continuous operation in harsh outdoor environments. Each reel undergoes abrasive blasting to create a controlled surface profile, ensuring maximum coating adhesion and long-term protection. A heavy-duty, multi-layer coating system featuring a zinc-rich epoxy primer, high-build epoxy intermediate layer, and a UV and abrasion-resistant polyurethane topcoat delivers a total dry film thickness of approximately 335 µm. This advanced protection system shields the reel from corrosion, impact, and environmental wear. Engineered to withstand extreme temperature swings, intense UV exposure, moisture, salt-laden air, and airborne abrasives, Thorburn's THRC5 maintains performance and durability in conditions where standard equipment quickly degrades. Ideal for manufacturing and processing plants, service bays, construction sites, and other demanding industrial applications exposed to severe climates and environmental stress.

THOR-REEL™ Series THR Utility Hose Reels



Specifications:

Drive Structure: 1" BSPT spindle with dual supports for stronger stability and reduced vibration.

Drive Motor: Enclosed stainless steel disc motor with a self-locking ratchet for positioning the hose at any length.

Guide Rail Assembly: Welded 5 mm base and 3 mm side plates with an adjustable guide arm for floor, wall, overhead, or truck mounting.

Input Interface: 90° BSPT stainless steel rotary joint for smooth, leak-free operation.

Reel Capacity:

3/8" Hose - Up to 30 m (100 ft)

1/2" Hose - Up to 30 m (100 ft)

3/4" Hose - Up to 23 m (70 ft)

1" Hose - Up to 15 m (50 ft)

Thorburn Part Number	Hose ID		Max. Working Pressure		Thread (Female BSPT)	Dimensions						Weight	
						Length		Width		Height			
	in	mm	bar	psi	in	in	mm	in	mm	in	mm	kg	lbs
THRS4-06/THRCS-06	3/8	10	21	305	3/8	19.4	492	8.1	206	20.5	521	15	33
THRS4-08/THRCS-08	1/2	13	21	305	1/2	19.4	492	8.1	206	20.5	521	15	33
THRS4-12/THRCS-12	3/4	19	35	508	3/4	26.3	667	12.0	305	26.4	670	54	119
THRS4-16/THRCS-16	1	25	35	508	1	26.3	667	12.0	305	26.4	670	53	117

Roller Position: A suffix code must be added after the model number to specify desired position. Reels are shipped in the BW position unless specified otherwise.

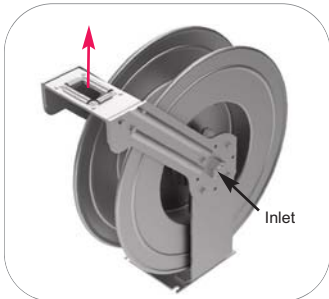

TW - (Top Wind)
RIGHT HAND INLET

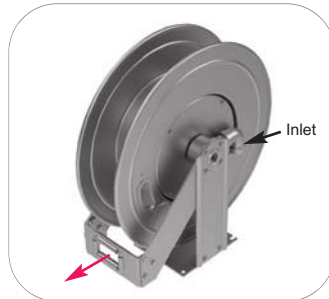

BW - (Bottom Wind)
RIGHT HAND INLET

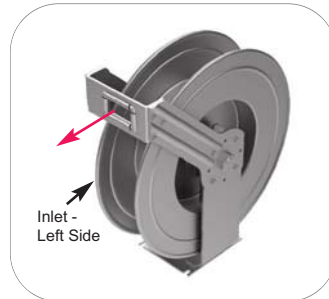

SW - (Side Wind)
LEFT HAND INLET



Rubber Hose Stopper Included

How To Order Thorburn THOR-REEL™ Series THR Utility Hose Reels

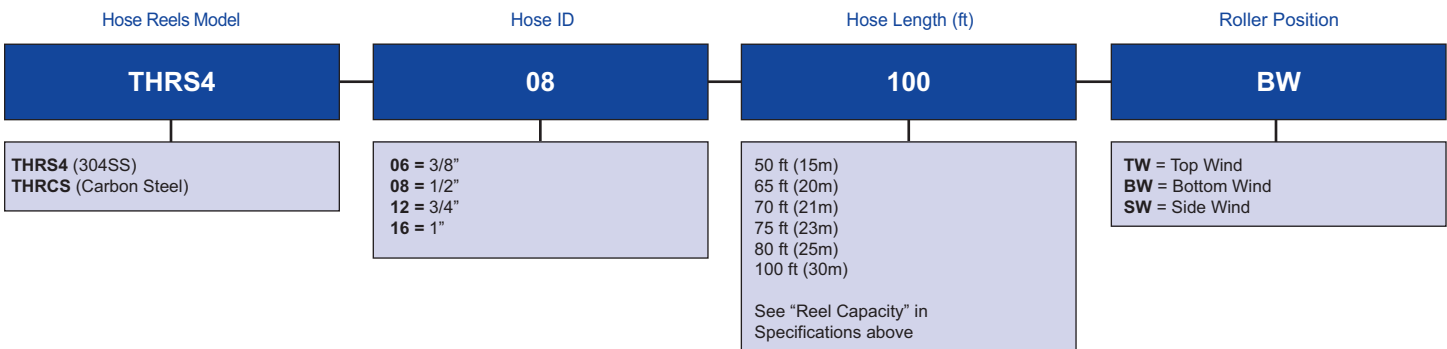

Thorburn THOR-REEL™ Series PC-Hose Reel Protective Cabinets



Thorburn THOR-REEL™ Series PC – Hose Reel Protective Cabinets are custom designed to suite the specific application. Engineered to deliver superior protection, cleanliness, and durability across both controlled indoor environments and demanding outdoor applications. Fully integrated with Thorburn THOR-REEL™ systems, the cabinet has easy access doors that provides a complete, unified solution that enhances both performance and presentation.



Thorburn PCI – Sanitary & Controlled Environments: Thorburn PCI protective reel cabinets are custom designed for indoor hygienic industries such as food & beverage, pharmaceutical, and clean processing facilities, Thorburn Series PCI are available in stainless steel construction. Its smooth, non-porous surfaces and sealed enclosure help prevent contamination while supporting strict sanitation protocols. Fully integrated with Thorburn THOR-REEL™ systems, it provides a clean, hygienic, and streamlined installation ideally suited for sanitary indoor environments, while supporting ease of cleaning, maintaining contamination control, and enhancing Thor-Reel longevity with reduced maintenance.

Thorburn PCO – Harsh & Industrial Environments: Thorburn PCO protective reel cabinets are custom designed for heavy-duty process industries, available in coated carbon steel or stainless steel, providing rugged, weather-resistant protection against dust, corrosive marine atmosphere, UV exposure, and severe environmental conditions including sandstorms. Built to withstand extreme temperatures and abrasive environments, the cabinet shields hose reels from degradation while maintaining a clean, organized appearance in the field. Fully integrated with Thorburn THOR-REEL™ systems, it delivers a professional, streamlined installation while extending hose reel life and reducing hose reel maintenance.

How To Order Thorburn THOR-REEL™ Series PC - Hose Reel Protective Cabinets

Protective Cabinet Model	Hose ID	Hose Length (ft)	Roller Position
PCO	08	100	BW
PCI (304SS) PCO (Carbon Steel)	06 = 3/8" 12 = 3/4" 08 = 1/2" 16 = 1"	50 ft (15m) 65 ft (20m) 70 ft (21m) 75 ft (23m) 80 ft (25m) 100 ft (30m)	TW = Top Wind BW = Bottom Wind SW = Side Wind

Thorburn Other Hose Accessories



Hose Bend Restrictors - Series TBR

Thorburn's hose bend restrictors are designed to limit the degree of bending without compromising the integrity of the hose assembly. The added protection prevents damage to the hose and extending its life cycle by preventing the hose-end from kinks, tears and excessive wear. The upper lip of Thorburn's hose bend restrictors firmly attaches to the coupling, holding the restrictor in place and eliminating the need for costly adhesives or clamps.

Thorburn Part Number	Sleeve ID (mm)		Length mm
	Lower	Upper	
TBR-20	15.7	17.8	134.4
TBR-40	17.0	19.3	145.8
TBR-60	19.1	21.6	163.3
TBR-80	20.7	23.5	177.3
TBR-100	22.1	25.3	197.1



Hose Abrasion Covers - Series TAC

Thorburn's hose abrasion covers protect hoses from abrasion and dramatically reduces the likelihood of hose failure while extending the lifespan of the hose. The unique spiral wrap design can be used for any application where cables, wires, and other similar lines need protection or organization.

Thorburn Part Number	Sleeve ID	
	mm	in
TAC-11	11.2	0.44
TAC-13	12.7	0.50
TAC-15	14.5	0.57
TAC-16	16.0	0.63
TAC-19	19.0	0.75
TAC-22	22.3	0.88
TAC-26	26.2	1.03
TAC-29	28.7	1.13
TAC-31	31.0	1.22
TAC-37	37.3	1.47
TAC-43	42.9	1.69
TAC-49	48.5	1.91
TAC-54	54.1	2.13
TAC-62	62.0	2.44
TAC-65	65.0	2.56



Hose Spring Guards - Series TSG

Thorburn Series TSG hose spring guards prevent kinking and flexing and protects the hose from abrasion and rough handling. Thorburn's hose spring guards slide on over the hose and run the full length of the hose for maximum protection. Most suitable for applications where potential hazards from abrasion and gouges are the greatest. Made from rust resistant steel wire.

Thorburn Part Number	Sleeve ID	
	mm	in
TSG-16	15.5	0.61
TSG-17	17.0	0.67
TSG-19	19.0	0.75
TSG-21	20.6	0.81
TSG-22	21.6	0.85
TSG-23	23.1	0.91
TSG-26	26.4	1.04
TSG-30	30.0	1.18
TSG-34	34.0	1.34
TSG-42	42.2	1.66
TSG-48	47.5	1.87
TSG-54	54.1	2.13
TSG-60	60.4	2.38
TSG-70	69.8	2.75
TSG-73	73.1	2.88

Chemical Resistance Guide

Interpretation of Chemical Resistance

The Chemical Resistance Chart that follows is a general guide only. Since many factors can affect the chemical resistance of a given product, you should test under your own conditions.

Chemical resistance is a measure of:

Permeation: the process by which a chemical agent migrates through a material at the molecular level

Penetration: the bulk flow of a chemical agent through porous materials, closures, seams, or imperfections in a material

Degradation: a damaging change in one or more physical property of a material after it's been exposed to a chemical agent

Elastomeric Chemical Resistance

Variables that affect the resistance of a compound to a chemical attack are:

Temperature of the Media Transmitted: Ratings given are based at 70°F (21°C). Higher temperatures increase the affect of chemicals on compounds. The amount of increase depends upon the polymer and the chemical. A compound quite suitable at room temperature might fail very quickly at higher temperatures. It is not recommended to operate outside hose temperature limits.

Service Conditions: A rubber compound usually swells when exposed to a chemical. Within a given percent of swell, a hose tube may function well if the hose is in a static condition, but may fail quickly if the hose is subject to flexing.

The Grade or Blend of the Rubber Compound: Basic polymers are sometimes mixed or blended to enhance a particular property for a specific service and the reaction to a particular chemical may therefore be somewhat different. When in doubt, a sample of the compound should always be tested with the particular chemical it is going to handle.

Thermoplastic Chemical Resistance

Thermoplastics have outstanding resistance to a wide range of chemical reagents. The chemical resistance of plastic piping is basically a function of the thermoplastic material and the compounding components. In general, the less compounding components used the better the chemical resistance. Thermoplastic pipes with significant filler percentages may be susceptible to chemical attack where an unfilled material may be affected to a lesser degree or not at all. Thermoplastic hose and tubing achieve their optimum physical properties at room temperature 68°F (20°C). As Thermoplastic materials are exposed to increased ambient temperatures, they soften and their physical properties change. It is advised to test the product in a controlled environment and consider all operating conditions prior to use. Types of thermoplastic material are: **PVC** (Polyvinyl Chloride) , **TPR** (Thermoplastic Rubber), **TPE** (Thermoplastic Elastomer), **TPU** (Thermoplastic Polyurethane), **UHMW** (Ultra High Molecular Weight Polyethylene).

Coupling Material Chemical Resistance

The tables provide an initial guide to the selection of materials and are intended to facilitate understanding of the different types of corrosion damage that can arise due to poor material selection. The chemical resistance of a material does not necessarily indicate the suitability of a fitting in a given application due to variables such as improper clamp and coupling application, special hose construction and gasket material. Ratings given are based at 70°F (21°C). Chemical compatibility varies greatly with temperature.

Material Compatibility Key

(A) Excellent

(B) Good

(C) Fair (Conditional)

(D) Unsatisfactory

(E) Contact Thorburn

(Y) Acceptable (Coupling Material Only)

(-) No Information

Elastomeric Chemical Resistance

Material (All ratings are based on 70°F)	Natural Rubber										
	SBR	Butyl	Nitrile	Neoprene	Hypalon	EPDM	Viton	XLPE	PTFE/TFE/PEP	Silicone	
Acetal	C	C	B	D	C	C	B	D	A	A	-
Acetaldehyde	C	D	A	D	C	C	A	D	A	A	-
Acetamide	C	C	A	B	B	B	A	B	A	A	-
Acetate Solvents	C	D	C	D	D	D	C	D	A	A	-
Acetic Acid (10%)	B	B	B	C	C	B	C	A	A	A	B
Acetic Acid (30%)	D	D	B	D	C	B	A	C	A	A	-
Acetic Acid (50%)	D	D	B	C	C	D	A	D	A	A	-
Acetic Acid (Glacial)	D	D	B	D	C	D	B	D	A	A	C
Acetic Anhydride	D	D	B	D	D	D	B	D	A	A	-
Acetic Ester (Ethyl Acetate)	D	D	B	D	D	D	B	D	A	A	-
Acetic Ether (Ethyl Acetate)	D	D	B	D	D	C	B	D	A	A	-
Acetic Oxide (Acetic Anhydride)	D	D	B	D	D	D	B	D	A	A	-
Acetone	B	C	A	D	C	C	A	D	A	A	D
Acetophenone	C	D	A	D	D	D	A	D	A	A	-
Acetyl Acetone	B	D	B	D	D	D	B	D	A	A	-
Acetyl Chloride	D	D	C	D	D	D	C	B	B	A	-
Acetylene	D	D	A	A	B	B	B	A	A	A	C
Acrylonitrile	C	D	D	D	C	C	D	D	A	A	-
Air	A	A	A	A	A	A	A	A	A	A	A
Alcohols Aliphatic	A	B	A	A	A	A	A	C	A	A	-
Alcohols, Aromatic	C	D	D	C	C	D	D	A	A	A	-
Alk-Tri (Trichlorethylene)	D	D	D	D	D	D	D	A	A	A	-
Allyl Alcohol	A	B	A	A	A	A	A	B	A	A	-
Allyl Bromide	D	D	D	D	D	D	D	B	B	A	-
Allyl Chloride	D	D	D	D	D	D	B	B	A	-	
Alum (Aluminum Potassium Sulfate)	A	A	A	A	A	A	A	A	A	A	-
Aluminum Acetate	C	C	A	C	C	B	A	A	A	A	-
Aluminum Chloride	A	A	A	A	A	A	A	A	A	A	A
Aluminum Fluoride	A	A	A	A	A	A	A	A	A	A	B
Aluminum Hydroxide	A	A	A	A	A	A	A	A	A	A	-
Aluminum Nitrate	A	A	A	A	A	A	A	A	A	A	-
Aluminum Phosphate	A	A	A	A	A	A	A	A	A	A	-
Aluminum Sulfate	A	A	A	A	A	A	A	A	A	A	A
Ammonia Anhydrous	A	C	A	A	A	B	A	D	A	A	-
Ammonia Gas (150°F)	Anhydrous Ammonia Hose Only										
Ammonia in Water	B	B	B	B	B	B	A	B	A	A	A
Ammonia Liquid	B	B	A	A	A	A	A	A	A	A	-
Ammonia, Gas (Cold)	Anhydrous Ammonia Hose Only										
Ammonium Carbonate	A	A	A	C	A	A	A	A	A	A	-
Ammonium Chloride	A	A	A	A	A	A	A	A	A	A	C
Ammonium Hydroxide	B	B	B	B	A	B	B	A	A	A	C
Ammonium Metaphosphate	A	A	A	A	A	A	A	A	A	A	-
Ammonium Nitrate	B	A	A	A	A	A	A	A	A	A	-
Ammonium Nitrite	A	A	A	A	A	A	A	A	A	A	A
Ammonium Persulfate	A	D	A	D	A	A	A	A	A	A	-
Ammonium Phosphate	A	A	A	A	A	A	A	A	A	A	A
Ammonium Sulfate	A	A	A	A	A	A	A	A	A	A	A
Ammonium Sulfide	A	A	A	A	A	A	A	A	A	A	-
Ammonium Sulfite	A	A	A	A	A	A	A	A	A	A	-
Ammonium Thiocyanate	A	A	A	A	A	A	A	A	A	A	-
Ammonium Thiosulfate	A	A	A	A	A	A	A	A	A	A	-
Amyl Acetate	C	D	B	D	D	D	B	D	A	A	D
Amyl Acetone	D	D	B	D	D	D	B	D	A	A	-
Amyl Alcohol	A	A	A	A	A	A	A	A	A	A	D

Material (All ratings are based on 70°F)	Natural Rubber										
	SBR	Butyl	Nitrile	Neoprene	Hypalon	EPDM	Viton	XLPE	PTFE/TFE/PEP	Silicone	
Amyl Borate	D	D	D	A	A	C	D	A	A	A	-
Amyl Chloride	D	D	D	D	D	D	D	A	A	A	-
Amyl Chloronaphthalene	D	D	D	D	D	D	D	A	A	A	-
Amyl Naphthalene	D	D	D	D	D	D	D	A	A	A	-
Amyl Oleate	D	D	B	D	D	D	B	C	A	A	-
Amyl Phenol	D	D	D	D	D	D	D	A	A	A	-
Amylamine	See Ammonia										
Anethole	D	D	D	D	D	D	D	B	B	A	-
Aniline	D	D	B	D	C	C	D	B	A	A	D
Aniline Dyes	B	B	B	C	B	B	B	B	A	A	D
Aniline Hydrochloride	B	C	B	B	D	B	B	B	A	A	-
Animal Fats	D	D	B	A	B	D	B	B	A	A	-
Animal Grease	D	D	D	B	B	D	C	A	A	A	-
Animal Oils	D	D	B	A	D	D	C	A	A	A	-
Ansul Ether	D	D	C	C	D	D	C	D	A	A	-
Antifreeze (Ethylene Glycol)	A	A	A	A	A	A	A	A	A	A	-
Antimony Pentachloride	D	D	C	D	D	D	C	A	B	A	-
Antimony Trichloride	D	D	A	B	B	D	B	B	A	A	-
Aqua Regia	D	D	D	D	D	C	C	B	D	A	-
Aromatic Hydrocarbons	D	D	D	C	D	D	D	A	A	A	-
Arquad	A	A	A	A	A	A	A	A	A	A	-
Arsenic Acid	A	A	A	A	A	A	A	A	A	A	-
Arsenic Chloride	D	D	B	D	B	D	B	D	D	A	-
Arsenic Trichloride	D	D	B	D	B	D	B	D	D	A	-
Asphalt	D	D	D	A	B	D	D	A	B	A	-
Astm #1 Oil	D	D	D	A	A	B	D	A	A	A	-
Astm #2 Oil	D	D	D	A	B	C	D	A	A	A	-
Astm #3 Oil	D	D	D	A	B	C	D	A	A	A	-
Aviation Gasoline	D	D	D	A	C	D	D	A	A	A	-
Barium Carbonate	A	A	A	A	A	A	A	A	A	A	-
Barium Chloride	A	A	A	A	A	A	A	A	A	A	A
Barium Hydroxide	A	A	A	A	A	A	A	A	A	A	A
Barium Sulfate	A	A	A	A	A	A	A	A	A	A	-
Barium Sulfide	A	A	A	A	A	A	A	A	A	A	A
Beer	F.D.A. Tube Required										
Beet Sugar Liquors	A	A	A	A	A	A	A	A	A	A	A
Benzaldehyde	D	D	B	D	D	D	B	D	A	A	-
Benzene (Benzol)	D	D	D	C	C	D	D	A	A	A	D
Benzene Sulfonic Acid	D	D	D	B	A	A	C	A	A	A	-
Benzine Solvent (Ligroin)	D	D	D	A	A	C	D	A	A	A	-
Benzoic Acid	D	D	B	D	B	B	B	A	A	A	-
Benzoic Aldehyde	D	D	D	D	D	D	D	D	A	A	-
Benzotrithloride	D	D	D	D	D	D	D	B	B	A	-
Benzoyl Chloride	D	D	D	D	D	D	D	B	B	A	-
Benzyl Acetate	D	D	B	D	D	B	B	D	A	A	-
Benzyl Alcohol	B	B	B	D	B	B	B	A	A	A	-
Benzyl Chloride	D	D	C	D	D	D	D	A	A	A	-
Bichromate of Soda (Sodium Dichromate)	D	D	A	D	B	B	C	A	A	B	-
Bichromate of Soda (Sodium Bichromate)	D	D	A	D	B	B	C	A	A	A	-
Black Sulfate Liquor	B	B	A	B	A	B	A	A	A	A	A
Blast Furnace Gas	D	D	C	C	B	B	C	A	A	B	A
Bleach Solutions	D	D	B	D	D	C	B	B	B	A	-
Borax	B	B	A	B	A	A	A	A	A	A	B
Bordeaux Mixture	B	B	A	A	A	A	A	A	A	A	-

Rating Codes: **A** = Excellent, **B** = Good, **C** = Fair Conditional, **D** = Unsatisfactory, (-) = No Data Available

Elastomeric Chemical Resistance

Material (All ratings are based on 70°F)	Natural Rubber	SBR	Butyl	Nitrile	Neoprene	Hypalon	EPDM	Viton	XLPE	PTFE/TFE/FEP	Silicone
	Brandy	F.D.A. Tube Required									
Brine	A	A	A	A	A	A	A	A	A	A	-
Bromine	D	D	D	D	D	C	D	C	D	A	D
Bromine Water	D	D	B	C	B	A	B	A	A	A	-
Bromobenzene	D	D	D	D	D	D	D	B	C	A	-
Bunker Oil	D	D	D	A	B	D	D	A	A	A	-
Butane	Use Butane-Propane Hose Only										
Butanol (Butyl Alcohol)	A	A	A	A	A	A	A	A	A	A	C
Butter (Non-F.D.A.)	C	C	B	A	A	A	B	A	A	A	-
Butyl Acetate	D	D	B	D	D	D	C	D	A	A	D
Butyl Acrylate	D	D	D	D	D	D	D	D	B	A	-
Butyl Benzene	D	D	D	D	D	D	D	A	A	A	-
Butyl Bromide	D	D	D	D	D	D	D	B	B	A	-
Butyl Butyrate	D	D	C	D	D	D	B	C	B	A	-
Butyl Carbitol	D	D	A	B	B	B	A	A	A	A	-
Butyl Cellosolve	D	D	A	B	B	B	A	D	A	A	-
Butyl Chloride	D	D	C	D	D	D	D	A	B	A	-
Butyl Ether	D	D	C	B	B	B	C	D	A	A	-
Butyl Ethyl Acetaldehyde	D	D	C	D	D	D	D	D	A	A	-
Butyl Ethyl Ether	D	D	C	D	D	B	C	C	A	A	-
Butyl Oleate	D	D	B	D	D	D	B	A	A	A	-
Butyl Phthalate	D	D	C	D	D	D	C	C	A	A	-
Butyl Stearate	D	D	C	B	D	D	C	A	A	A	-
Butylamine	See Ammonia										
Butyric Acid	C	D	C	C	C	B	C	C	A	A	-
Butyric Anhydride	C	D	C	C	C	B	C	C	A	A	-
Butyraldehyde	C	D	C	C	D	B	C	C	A	A	-
Calcium Acetate	C	D	D	D	D	D	D	D	A	A	-
Calcium Bisulfate	C	D	A	D	D	D	A	D	A	A	C
Calcium Bisulfite	A	A	A	A	A	A	A	A	A	A	-
Calcium Carbonate	A	A	A	A	A	A	A	A	A	A	-
Calcium Chloride	A	A	A	A	A	A	A	A	A	A	A
Calcium Hydroxide	A	A	A	A	A	A	A	A	A	A	A
Calcium Hypochlorite	A	B	A	B	A	B	A	C	A	A	C
Calcium Nitrate	D	D	B	D	D	C	B	A	B	A	-
Calcium Sulfate	A	A	A	A	A	A	A	A	A	A	-
Calcium Sulfide	A	A	A	A	A	A	A	A	A	A	-
Calcium Sulfite	A	A	A	A	A	A	A	A	A	A	-
Caliche Liquor (Crude Sodium Nitrate)	A	A	A	A	A	A	A	A	A	A	B
Cane Sugar Liquors (Non F.D.A.)	A	A	A	A	A	A	A	A	A	A	A
Carbitol	D	D	A	D	A	B	B	B	A	A	-
Carbitol Acetate	D	D	A	D	A	B	B	B	A	A	-
Carbolic Acid (Phenol)	D	D	B	D	D	D	B	D	A	A	D
Carbon Bisulfide	D	D	B	C	C	C	B	A	A	A	-
Carbon Dioxide	See Carbon Disulfide										
Carbon Disulfide	A	A	A	A	A	A	A	A	A	A	D
Carbon Monoxide	D	D	D	D	D	D	D	A	A	A	A
Carbon Tetrachloride	A	A	A	A	A	A	A	A	A	A	D
Carbon Tetrafluoride	D	D	D	C	D	D	D	A	C	A	-
Carbonic Acid	D	D	D	C	D	D	D	A	C	A	-
Castor Oil	A	A	A	A	A	A	A	A	A	A	A
Caustic Potash (Potassium Hydroxide)	C	D	B	A	B	C	B	A	A	A	-
Caustic Soda (Sodium Hydroxide)	A	B	A	A	B	A	A	C	A	A	-

Material (All ratings are based on 70°F)	Natural Rubber	SBR	Butyl	Nitrile	Neoprene	Hypalon	EPDM	Viton	XLPE	PTFE/TFE/FEP	Silicone
	Cellosolve	D	D	B	B	A	B	B	C	A	A
Cellulose Acetate	C	D	B	D	C	C	B	D	B	A	D
Cellulube	C	D	B	D	D	D	A	C	A	A	-
China Wood Oil (Tung Oil)	D	D	B	A	B	B	B	A	A	A	D
Chlorinated Hydrocarbons	D	D	D	D	D	D	D	A	B	A	-
Chlorine Dioxide	D	D	D	D	D	C	D	A	B	A	-
Chlorine Gas (Dry)	C	C	C	C	D	B	C	B	B	A	D
Chlorine Water Solutions	C	D	C	D	D	B	C	A	A	A	-
Chloroacetic Acid	B	D	C	D	D	D	C	C	A	A	-
Chloroacetone	D	D	B	D	D	D	C	D	A	A	-
Chlorobenzene	D	D	D	D	D	D	D	A	B	A	-
Chlorobutadiene	D	D	D	D	D	D	D	A	B	A	-
Chlorobutane	D	D	D	D	D	D	D	A	B	A	-
Chloroform	D	D	D	D	D	D	D	A	B	A	-
Chloropentane	D	D	D	D	C	D	D	A	A	A	-
Chlorophenol	D	D	D	D	D	D	D	B	B	A	-
Chloropropanone	D	D	C	D	D	D	C	D	A	A	-
Chlorosulfonic Acid	D	D	D	D	D	C	D	D	B	A	D
Chlorothene (Trichloroethane)	D	D	D	D	D	D	D	A	B	A	-
Chlorotoluene	D	D	D	D	D	D	D	A	B	A	-
Chromic Acid	D	D	D	D	D	A	C	C	A	A	C
Citric Acid	A	A	A	B	B	A	A	A	A	A	A
Coal Oil	D	D	D	A	B	D	D	A	A	A	-
Coal Tar	D	D	D	A	B	B	B	A	A	A	-
Coal Tar Naptha	D	D	D	C	C	D	D	A	A	A	-
Cobalt Chloride	A	A	A	A	A	A	A	A	A	A	-
Coconut Oil	D	D	B	A	B	B	A	A	A	A	-
Cod Liver Oil	D	D	A	A	B	B	A	A	A	A	-
Coke Oven Gas	D	D	C	D	D	B	D	A	A	A	-
Copper Arsenate	A	A	A	A	A	A	A	A	A	A	-
Copper Chloride	A	A	A	A	A	A	A	A	A	A	A
Copper Cyanide	A	A	A	A	A	A	A	A	A	A	-
Copper Nitrate	A	A	A	A	A	A	A	A	A	A	-
Copper Nitrite	A	A	A	A	A	A	A	A	A	A	-
Copper Sulfate	C	A	A	A	A	A	A	A	A	A	A
Copper Sulfide	C	A	A	A	A	A	A	A	A	A	-
Corn Oil	D	D	B	A	B	B	B	A	A	A	A
Cottonseed Oil	D	D	A	A	B	A	A	A	A	A	A
Creosols	D	D	D	C	C	C	D	A	A	A	-
Creosote (Coal Tar)	D	D	D	B	C	C	D	A	A	A	C
Creosote (Wood)	D	D	D	B	C	C	D	A	A	A	D
Cresylic Acid	D	D	D	C	C	C	D	A	A	A	-
Crude Oil	D	D	D	C	C	C	D	A	A	A	-
Cumene	D	D	D	A	B	D	D	A	A	A	-
Cupric Carbonate	D	D	D	C	C	D	D	A	A	A	-
Cupric Chloride	C	C	A	B	B	B	A	A	A	A	-
Cupric Nitrate	C	C	A	A	B	A	A	A	A	A	-
Cupric Nitrite	C	C	A	A	B	A	A	A	A	A	-
Cupric Sulfate	C	C	A	A	B	A	A	A	A	A	-
Cyclohexane	C	B	A	A	B	B	A	A	A	A	-
Cyclohexanol	D	D	D	D	D	D	D	C	A	A	-
Cyclohexanone	D	D	D	B	D	D	D	A	A	A	-
Cyclopentane	D	D	D	B	B	D	D	B	A	A	-
D.M.P. (Dimethyl Phenols)	B	D	D	D	D	D	D	D	C	A	-

Rating Codes: **A** = Excellent, **B** = Good, **C** = Fair Conditional, **D** = Unsatisfactory, (-) = No Data Available

Elastomeric Chemical Resistance

Material (All ratings are based on 70°F)	Natural Rubber									
	SBR	Butyl	Nitrile	Neoprene	Hypalon	EPDM	Viton	XLPE	PTFE/TFE/FEP	Silicone
DDT in Kerosene	D	D	C	D	D	D	A	A	A	-
Decaline (Deklin)	D	D	A	B	C	D	A	A	A	-
Decane	D	D	D	D	D	D	A	A	A	-
Detergent Solutions	D	D	D	D	D	D	A	A	A	-
Diacetone Alcohol	B	B	A	A	A	A	A	A	A	-
Diethylamine	See Ammonia									
Dibenzyl Ether	D	D	D	D	D	D	C	A	A	-
Dibenzyl Sebacate	D	D	D	D	D	D	C	A	A	-
Dibromobenzene	C	D	B	D	D	C	B	B	A	-
Dibutyl Sebacate	D	D	B	D	D	B	D	B	A	-
Dibutylamine	See Ammonia									
Dibutylether	B	C	C	B	A	C	B	D	A	-
Dibutylphthalate	D	D	B	D	D	D	A	D	A	-
Dicalcium Phosphate	A	A	A	A	A	A	A	A	A	-
Dichloroacetic Acid	D	D	C	D	D	D	C	C	A	-
Dichlorobutane	D	D	D	D	D	D	A	A	A	-
Dichlorodifluoromethane (Freon 12)	D	D	D	B	D	D	D	B	A	-
Dichloroethane	D	D	D	D	D	D	D	A	A	-
Dichloroethyl Ether	D	D	D	D	D	D	C	A	A	-
Dichloroethylene	D	D	D	D	D	D	A	A	A	D
Dichlorohexane	D	D	D	D	D	D	A	A	A	-
Dichloroisopropyl Ether	D	D	C	D	D	D	C	C	A	-
Dichloromethane	D	D	D	D	D	D	A	A	A	-
Dichloropentane	D	D	D	D	D	D	A	A	A	-
Dicyclohexylamine	See Ammonia									
Dieldrin in Xylene	D	D	D	D	D	D	A	A	A	-
Dieldrin in Xylene and Water Spray	D	D	D	B	B	D	D	A	A	-
Diesel Oil	D	D	D	A	B	C	D	A	A	D
Diethanolamine	See Ammonia									
Diethyl Benzene	D	D	D	D	D	D	A	A	A	-
Diethyl Ether	D	D	D	B	C	C	C	D	A	-
Diethyl Oxalate	A	A	A	D	D	D	A	C	A	-
Diethyl Phthalate	D	D	A	D	D	D	B	C	A	-
Diethyl Sebacate	D	D	A	D	D	D	B	C	A	-
Diethyl Sulfate	D	D	B	D	D	D	B	D	A	-
Diethyl Triamine	B	C	A	B	B	C	B	C	A	-
Diethylamine	See Ammonia									
Diethylene Dioxide	D	D	B	D	D	D	B	D	A	-
Diethylenetriamine	See Ammonia									
Dihydroxyethyl Amine	See Ammonia									
Dihydroxyethyl Ether	A	A	A	A	B	A	B	A	A	-
Diisobutyl Ketone	D	D	B	D	D	D	B	D	A	-
Diisobutylene	D	D	A	B	D	D	A	A	A	-
Diisodecyl Adipate	D	D	A	D	D	C	A	C	A	-
Diisodecyl Phthalate	D	D	A	D	D	C	A	C	A	-
Diisooctyl Adipate	D	D	A	D	D	C	A	C	A	-
Diisooctyl Phthalate	B	C	A	B	B	C	A	C	A	-
Diisopropanol Amine	D	D	D	C	D	D	D	A	A	-
Diisopropyl Benzene	D	D	D	B	C	D	D	B	A	-
Diisopropyl Ether	D	D	A	D	D	D	A	D	A	-
Diisopropyl Ketone	D	D	D	D	D	D	C	A	A	-
Dilauryl Ether	D	D	D	D	D	D	A	A	A	-
Dimethyl Benzene	B	C	A	D	C	C	A	D	A	-
Dimethyl Ketone (Acetone)	D	D	A	D	D	D	B	C	A	-

Material (All ratings are based on 70°F)	Natural Rubber									
	SBR	Butyl	Nitrile	Neoprene	Hypalon	EPDM	Viton	XLPE	PTFE/TFE/FEP	Silicone
Dimethyl Phthalate	D	D	A	D	D	D	B	C	A	-
Dimethyl Sulfate	D	D	D	D	D	D	D	A	A	-
Dimethyl Sulfide	D	D	D	D	D	D	C	B	A	-
Dimethylamine	See Ammonia									
Dimethylaniline	D	D	D	D	D	D	D	B	A	-
Dimethylformamide (DMF)	C	C	C	D	C	C	C	D	A	-
Dinitrobenzene	D	D	C	D	C	D	C	A	A	-
Dinitrotoluene	D	D	D	D	D	D	C	A	A	-
Diocetyl Adipate (DOA)	D	D	B	D	D	D	B	C	A	-
Diocetyl Phthalate (DOP)	D	D	B	D	D	D	B	A	A	D
Diocetyl Sebacate (DOS)	D	D	B	D	D	D	B	B	A	-
Dioctylamine	See Ammonia									
Dioxane	D	D	B	D	D	D	B	D	A	-
Dioxolane	D	D	C	D	D	D	B	C	A	-
Dipentene (Limonene)	D	D	D	C	D	D	D	A	A	-
Diphenyl (Biphenyl)	D	D	D	D	D	D	D	A	A	-
Diphenyl Oxide (Phenylether)	D	D	D	D	D	C	D	A	A	-
Dipropyl Ketone	D	D	B	D	D	D	B	D	A	-
Dipropylamine	See Ammonia									
Dipropylene Glycol	A	A	A	A	A	A	A	A	A	-
Disodium Phosphate	A	A	A	A	A	A	A	A	A	-
Divinyl Benzene	D	D	D	D	D	D	D	D	A	-
Dodecyl Benzene	D	D	D	D	D	D	D	A	A	-
Dodecyl Toluene	D	D	D	D	D	D	D	A	A	-
Dow-Per (Perchloroethylene)	D	D	D	C	D	D	D	A	A	-
Dowfume W 40, 100%	D	D	D	D	C	C	C	C	B	-
Dowtherm Oil, A & E	D	D	D	D	D	C	D	A	A	-
Dowtherm S.R.-1	A	A	A	A	A	A	A	A	A	-
Dry Cleaning Fluids	D	D	D	C	D	D	D	A	B	-
Epichlorohydrin	D	D	B	D	D	C	B	D	B	-
Ethanol (Ethyl Alcohol)	A	A	A	A	A	A	A	A	A	-
Ethanolamine	See Ammonia									
Ethers	D	D	C	D	D	C	D	C	A	D
Ethyl Acetate	D	D	B	D	D	D	B	D	A	B
Ethyl Acetoacetate	D	D	B	D	D	D	B	D	A	-
Ethyl Acrylate	D	D	C	D	D	D	D	B	A	-
Ethyl Benzene	D	D	D	C	D	D	D	A	B	-
Ethyl Benzoate	D	D	B	B	C	C	B	C	A	-
Ethyl Butyl Alcohol	A	A	A	A	A	A	A	A	A	-
Ethyl Butyl Amine	See Ammonia									
Ethyl Butyl Ketone	D	D	B	D	D	D	B	D	A	-
Ethyl Cellulose	B	B	B	B	B	B	B	D	A	C
Ethyl Chloride	C	C	D	C	C	D	D	A	A	C
Ethyl Dichloride	D	D	D	D	D	D	D	B	B	-
Ethyl Ether	D	D	D	C	D	D	D	D	A	-
Ethyl Formate	D	D	B	D	D	D	C	D	A	-
Ethyl Hexanol	A	A	A	A	A	A	A	B	A	-
Ethyl Methyl Ketone	C	D	B	D	D	D	B	D	A	-
Ethyl Oxalate	A	A	A	D	D	D	B	C	A	-
Ethyl Phthalate	D	D	A	D	D	D	B	C	A	-
Ethyl Propyl Ether	D	D	D	C	D	D	D	C	A	-
Ethyl Propyl Ketone	D	D	B	D	D	D	B	D	A	-
Ethyl Silicate	C	C	A	A	A	A	A	A	A	-
Ethyl Sulfate	D	D	B	D	D	D	B	D	A	-

Rating Codes: **A** = Excellent, **B** = Good, **C** = Fair Conditional, **D** = Unsatisfactory, (-) = No Data Available



Elastomeric Chemical Resistance

Material (All ratings are based on 70°F)	Material										
	Natural Rubber	SBR	Butyl	Nitrile	Neoprene	Hypalon	EPDM	Viton	XLPE	PTFE/TFE/FEP	Silicone
Ethylene	D	D	D	A	B	C	D	A	A	A	-
Ethylene Bromide	D	D	D	C	D	D	D	A	B	A	-
Ethylene Chloride	D	D	D	C	D	D	D	A	B	A	-
Ethylene Diamine	See Ammonia										
Ethylene Dibromide	D	D	D	C	D	D	D	B	B	A	-
Ethylene Dichloride	D	D	D	C	D	D	D	B	B	A	-
Ethylene Glycol	A	A	A	A	A	A	A	A	A	A	-
Ethylene Oxide	D	D	C	D	D	D	C	D	C	A	-
Ethylene Trichloride (Trichloroethylene)	D	D	D	C	D	D	D	A	B	A	-
EX TRI (Trichloroethylene)	D	D	D	C	D	D	D	A	B	A	-
Fatty Acids	D	D	D	B	B	B	C	A	A	A	-
Ferric Bromide	A	A	A	A	A	A	A	A	A	A	-
Ferric Chloride	A	A	A	A	A	A	A	A	A	A	A
Ferric Nitrate	A	A	A	A	A	A	A	A	A	A	-
Ferric Sulfate	A	A	A	A	A	A	A	A	A	A	B
Ferrous Acetate	D	D	A	D	D	D	B	D	A	A	-
Ferrous Ammonium Sulfate	A	A	A	A	A	A	A	A	A	A	-
Ferrous Chloride	A	A	A	A	A	A	A	A	A	A	-
Ferrous Hydroxide	B	C	A	B	A	B	A	C	A	A	-
Ferrous Sulfate	A	A	A	A	A	A	A	A	A	A	-
Fish Oil	D	D	A	A	A	A	A	A	A	A	-
Fluorine	D	D	D	D	D	D	D	D	D	A	-
Fluoroboric Acid	A	C	A	A	B	A	A	C	A	A	-
Fluosilicic Acid	B	B	A	B	B	A	B	A	A	A	-
Formaldehyde (Formalin)	C	C	A	B	B	B	B	A	A	A	B
Formamide	A	A	A	A	A	A	A	D	A	A	-
Formic Acid	B	B	A	C	C	C	C	D	B	A	C
Freon 11	D	D	D	A	B	A	D	A	A	A	-
Freon 12	D	D	D	B	C	D	C	B	B	A	-
Freon 13	A	A	A	A	A	A	A	A	A	A	-
Freon 13B1	A	A	A	A	A	A	A	A	A	A	-
Freon 21	D	D	D	D	B	D	D	D	A	A	-
Freon 22	D	D	A	D	A	D	A	D	A	A	-
Freon 31	B	B	A	D	A	B	A	D	A	A	-
Freon 32	A	A	A	A	A	A	A	D	A	A	-
Freon 112	D	D	D	B	B	B	D	A	A	A	-
Freon 113	C	B	D	A	A	A	D	B	A	A	-
Freon 114	A	A	A	A	A	A	A	B	A	A	-
Freon 114B2	D	C	D	B	A	A	D	B	A	A	-
Freon 115	A	A	A	A	A	A	A	B	A	A	-
Freon 142B	A	A	A	A	A	A	A	D	A	A	-
Freon 152A	A	A	A	A	A	C	A	D	A	A	-
Freon 218	A	A	A	A	A	A	A	A	A	A	-
Freon 502	A	A	A	B	A	A	A	B	A	A	-
Freon BF	D	D	D	B	B	B	D	A	A	A	-
Freon C316	A	A	A	A	A	A	A	A	A	A	-
Freon C318	A	A	A	A	A	A	A	A	A	A	-
Freon MF	D	B	D	A	C	B	D	A	A	A	-
Freon T-P35	A	A	A	A	A	A	A	A	A	A	-
Freon T-WD 602	C	B	A	A	B	B	B	A	A	A	-
Freon TA	A	A	A	A	A	A	A	C	A	A	-
Freon TC	D	B	A	A	A	A	B	A	A	A	-
Freon TF	C	B	A	A	A	A	A	A	A	A	-
Freon TMC	B	C	B	B	B	B	B	A	A	A	-

Material (All ratings are based on 70°F)	Material										
	Natural Rubber	SBR	Butyl	Nitrile	Neoprene	Hypalon	EPDM	Viton	XLPE	PTFE/TFE/FEP	Silicone
Fuel Oil	D	D	D	A	B	C	D	A	A	A	D
Fuel, ASTM - A	D	D	D	A	A	C	D	A	A	A	-
Fuel, ASTM - B	D	D	D	A	B	C	D	A	A	A	-
Fuel, ASTM - C	D	D	D	B	C	D	D	A	B	A	-
Fumaric Acid	A	A	D	A	B	D	A	A	A	A	-
Furan	D	D	C	D	D	D	C	D	A	A	-
Furfural	D	D	B	D	C	B	B	D	A	A	D
Furfuryl Alcohol	D	D	C	D	C	C	C	D	A	A	-
Gallic Acid	A	A	B	B	B	B	B	B	A	A	-
Gasoline (Hi-Test)	D	D	D	A	B	D	D	A	A	A	D
Gasoline (Lead Free)	D	D	D	B	B	D	D	A	A	A	D
Gasoline (Regular)	D	D	D	A	A	C	D	A	A	A	D
Gelatin	A	A	A	A	A	A	A	A	A	A	A
Gluconic Acid	D	D	C	C	C	B	C	A	A	A	-
Glucose	A	A	A	A	A	A	A	A	A	A	A
Glue	A	A	A	A	A	A	A	A	A	A	A
Glycerine (Glycerol)	A	A	A	A	A	A	A	A	A	A	A
Glycols	A	A	A	A	A	A	A	A	A	A	-
Grease	D	D	D	A	B	C	D	A	A	A	-
Green Sulfate Liquor	A	A	A	A	B	A	A	B	A	A	A
Halowax Oil	D	D	D	D	D	D	D	A	A	A	-
Heptachlor (in Petroleum Solvents)	D	D	D	B	B	D	D	A	A	A	-
Heptachlor (in Petroleum Solvents, Water Spray)	D	D	D	B	B	D	D	A	A	A	-
Heptanal (Heptaldehyde)	D	D	D	D	D	D	B	D	A	A	-
Heptane Carboxylic Acid	D	D	C	C	B	B	C	A	A	A	-
Heptane	D	D	D	A	A	B	D	A	A	A	-
Hexaldehyde (n-Hexaldehyde)	D	D	B	D	B	C	B	D	A	A	-
Hexane	D	D	D	A	A	C	D	A	A	A	-
Hexanol (Hexyl Alcohol)	A	A	A	A	A	A	A	A	A	A	-
Hexene	D	D	D	B	B	C	D	A	A	A	-
Hexyl Methyl Ketone	D	D	B	D	D	D	B	D	A	A	-
Hexylamine	See Ammonia										
Hexylene	D	D	D	A	B	D	C	A	B	A	-
Hexylene Glycol	A	A	A	A	A	A	A	A	A	A	-
Hi-Tri (Trichloroethylene)	D	D	D	C	D	D	D	A	B	A	-
Hydraulic Fluid (Petroleum)	D	D	D	A	B	B	D	A	A	A	C
Hydraulic Fluid (Phosphate Ester Base)	D	D	A	D	D	D	A	D	A	A	D
Hydraulic Fluid (Poly Alkyene Glycol Base)	B	B	A	A	A	A	A	A	A	A	D
Hydrobromic Acid	A	D	A	D	C	A	B	A	A	A	D
Hydrochloric Acid, 5%	A	B	A	C	C	A	B	A	A	A	D
Hydrochloric Acid, 15%	A	D	B	D	D	A	C	A	A	A	D
Hydrochloric Acid, 37%	B	D	C	D	D	B	C	C	A	A	D
Hydrocyanic Acid	B	C	A	B	C	A	B	B	A	A	B
Hydrofluoric Acid	B	D	B	D	C	A	B	B	A	A	D
Hydrofluosilicic Acid	A	D	A	D	C	A	B	B	A	A	-
Hydrogen Gas	B	B	A	A	A	A	B	A	A	A	C
Hydrogen Peroxide, 3%	A	B	A	B	C	A	B	A	A	A	A
Hydrogen Peroxide, 10%	D	D	C	D	C	C	C	A	A	A	A
Hydrogen Peroxide, 30%	D	D	D	D	D	D	C	A	A	A	A
Hydrogen Peroxide, 90%	D	D	D	D	D	D	C	B	B	A	A
Hydrogen Sulfide	D	D	A	D	A	B	A	A	A	A	D
Hydroquinone	B	B	B	D	D	C	B	D	A	A	-
Hypochlorous Acid	B	B	B	D	B	A	B	A	A	A	-

Rating Codes: A = Excellent, B = Good, C = Fair Conditional, D = Unsatisfactory, (-) = No Data Available

Elastomeric Chemical Resistance

Material (All ratings are based on 70°F)	Elastomer										
	Natural Rubber	SBR	Butyl	Nitrile	Neoprene	Hypalon	EPDM	Viton	XLPE	PTFE/TFE/FEF	Silicone
Ink Oil (Linseed Oil Base)	D	D	B	B	B	B	B	A	A	-	-
Insulating Oil	D	D	D	A	B	D	D	A	A	-	-
Iodine	D	D	D	D	D	C	D	C	A	A	-
Iron Acetate	D	D	A	D	D	D	B	D	A	A	-
Iron Hydroxide	C	C	A	B	A	B	B	C	A	A	-
Iron Salts	A	A	A	A	A	A	A	A	A	A	-
Iron Sulfate	A	A	A	A	A	A	A	A	A	A	-
Iron Sulfide	A	A	A	A	A	A	A	A	A	A	-
Isoamyl Acetate	D	D	A	D	D	D	B	D	A	A	-
Isoamyl Alcohol	A	A	A	A	A	A	A	A	A	A	-
Isoamyl Bromide	D	D	D	D	D	D	D	B	B	A	-
Isoamyl Butyrate	D	D	C	D	D	D	C	D	B	A	-
Isoamyl Chloride	D	D	C	D	D	D	D	B	B	A	-
Isoamyl Ether	D	D	D	D	D	D	D	D	A	A	-
Isoamyl Phthalate	D	D	A	D	D	D	B	C	A	A	-
Isobutane	D	D	D	A	A	D	D	A	A	A	-
Isobutanol (Isobutyl Alcohol)	A	A	A	A	A	A	A	A	A	A	A
Isobutyl Acetate	D	D	A	D	D	D	B	D	A	A	-
Isobutyl Aldehyde	C	D	B	D	D	D	B	D	A	A	-
Isobutyl Amine	B	C	B	D	D	C	B	D	A	A	-
Isobutyl Bromide	D	D	D	D	D	D	D	B	B	-	-
Isobutyl Carbinol	A	A	A	A	B	A	A	B	A	A	-
Isobutyl Chloride	D	D	D	D	D	D	D	B	B	A	-
Isobutyl Ether	D	D	D	D	D	D	D	D	A	A	-
Isobutylene	D	D	D	C	C	D	D	A	A	A	-
Isocane	D	D	D	A	A	B	D	A	A	A	D
Isocyanates	C	D	B	D	D	C	B	C	B	-	-
Isopentane	D	D	D	A	A	D	D	A	B	A	-
Isopropyl Acetate	D	D	A	D	D	C	B	D	A	A	-
Isopropyl Alcohol (Iso-propanol)	A	A	A	A	A	A	B	B	B	A	A
Isopropyl Amine	B	D	B	C	A	C	B	D	A	A	-
Isopropyl Benzene	D	D	D	D	D	D	D	A	A	A	-
Isopropyl Chloride	D	D	D	D	D	D	D	B	B	A	-
Isopropyl Ether	D	D	D	C	D	C	D	D	A	A	-
Isopropyl Toluene	D	D	D	D	D	D	D	A	A	A	-
Jet Fuels (JP1-JP6)	D	D	D	A	B	C	D	A	A	A	-
Ketones	B	B	B	D	D	D	B	D	A	A	-
Kerosene	D	D	D	A	B	C	D	A	A	A	D
Lacquer Solvents	D	D	D	D	D	D	D	D	A	A	D
Lacquers	D	D	D	D	D	D	D	D	A	A	D
Lactic Acid	B	B	B	A	A	A	B	A	A	A	A
Lard	D	D	D	A	B	D	C	A	A	A	-
Lauryl Alcohol	A	A	A	A	A	A	A	B	A	A	-
Lead Acetate	D	D	A	C	C	D	B	C	A	A	-
Lead Nitrate	A	A	A	A	A	A	A	A	A	A	-
Lead Sulfamate	B	B	A	B	A	B	A	A	A	A	-
Lead Sulfate	A	A	A	A	A	A	A	A	A	A	-
Ligroin	D	D	D	A	A	D	D	A	A	A	-
Lime Water	D	D	A	C	A	A	A	A	A	A	-
Lindol (Tricresyl Phosphate)	D	D	A	D	D	D	A	A	A	A	-
Linseed Oil	D	D	A	A	B	B	B	A	A	A	A
Liquid Petroleum Gas	D	D	D	A	B	D	D	A	A	A	-
Liquid Soap	A	A	A	A	A	A	A	A	A	A	-
Lubricating Oils	D	D	D	A	B	C	D	A	A	A	C

Material (All ratings are based on 70°F)	Elastomer										
	Natural Rubber	SBR	Butyl	Nitrile	Neoprene	Hypalon	EPDM	Viton	XLPE	PTFE/TFE/FEF	Silicone
Lye (Sodium Hydroxide)	A	B	A	B	A	A	A	D	A	A	-
Magnesium Acetate	D	D	A	D	D	D	B	D	A	A	-
Magnesium Carbonate	A	A	A	A	A	A	A	A	A	A	-
Magnesium Chloride	A	A	A	A	A	A	A	A	A	A	A
Magnesium Hydrate	A	B	A	B	A	B	A	B	A	A	-
Magnesium Hydroxide	A	A	A	A	A	A	B	A	A	A	B
Magnesium Nitrate	A	A	A	A	A	A	A	A	A	A	-
Magnesium Sulfate	A	A	A	A	A	A	A	A	A	A	A
Malathion 50 (in Aromatic Solvents)	D	D	D	C	C	D	D	A	A	A	-
Malathion 50 (in Aromatic Solvents Water Spray)	D	D	D	A	A	D	D	A	A	A	-
Maleic Acid	D	D	C	D	C	D	C	A	B	A	-
Maleic Anhydride	D	D	C	D	C	D	C	A	A	A	-
Malic Acid	A	B	D	B	C	B	D	A	A	A	-
Manganese Sulfate	A	A	A	A	A	A	A	A	A	A	-
Manganese Sulfide	C	A	A	A	B	A	B	A	A	A	-
Manganese Sulfite	C	A	A	A	B	A	B	A	A	A	-
Mercuric Chloride	B	B	B	C	C	B	C	A	A	A	A
Mercury	B	B	A	A	B	A	A	A	A	A	-
Methacrylic Acid	B	D	D	B	D	B	C	B	A	A	-
Methane	D	D	D	A	B	B	D	A	A	A	-
Methyl Acetate	C	D	B	D	D	D	B	D	A	A	-
Methyl Acrylate	C	D	B	D	C	D	B	D	A	A	-
Methyl Alcohol (Methanol)	A	A	A	A	A	A	A	C	A	A	A
Methyl Benzene (Toluene)	D	D	D	D	D	D	D	D	D	A	-
Methyl Bromide	D	D	B	B	D	D	B	A	A	A	-
Methyl Butyl Ketone	D	D	B	D	D	D	B	D	A	A	-
Methyl Cellosolve	D	D	B	C	B	C	B	D	A	A	-
Methyl Chloride	D	D	B	C	B	C	B	D	A	A	D
Methyl Cyclohexane	D	D	D	C	D	D	C	B	C	A	-
Methyl Ethyl Ketone (MEK)	B	D	B	D	D	D	B	D	A	A	D
Methyl Formate	C	C	B	D	B	C	B	C	B	A	-
Methyl Hexanol	A	A	A	A	A	A	A	B	A	A	-
Methyl Hexyl Ketone	D	D	B	D	D	D	B	D	A	A	-
Methyl Isobutyl Carbinol	B	C	A	B	B	B	A	B	A	A	-
Methyl Isobutyl Ketone (MIBK)	D	D	B	D	D	D	B	D	A	A	-
Methyl Isopropyl Ketone	D	D	B	D	D	D	B	D	A	A	-
Methyl Methacrylate	D	D	D	D	D	B	D	D	B	A	-
Methyl Propyl Ether	D	D	D	D	D	D	D	D	A	A	-
Methyl Propyl Ketone	D	D	B	D	D	D	B	D	A	A	C
Methyl Salicylate	D	D	B	D	D	D	B	C	B	A	-
Methylene Bromide	D	D	D	D	D	D	D	B	B	A	-
Methylene Chloride	D	D	D	D	D	D	D	B	A	A	-
Mineral Oil	D	D	D	A	B	B	D	A	A	A	A
Mineral Spirits	D	D	D	A	B	D	D	A	A	A	-
Monochloro difluoromethane (Freon 22)	D	D	A	D	A	D	A	D	A	A	-
Monochlorobenzene	D	D	D	D	D	D	D	A	A	A	-
Monoethanolamine	See Ammonia										
Monomethylether	B	B	A	A	A	C	A	C	A	A	-
Monovinyl Acetate	D	D	B	D	D	C	C	C	A	A	-
Motor Oil	D	D	D	A	A	D	D	A	A	A	-
Muriatic Acid	See Hcl 37%										
Naphtha	D	D	D	A	B	D	D	A	A	A	-
Napthalene	D	D	D	D	D	D	D	A	B	A	-

Rating Codes: **A** = Excellent, **B** = Good, **C** = Fair Conditional, **D** = Unsatisfactory, (-) = No Data Available



Elastomeric Chemical Resistance

Material (All ratings are based on 70°F)	Natural Rubber	SBR	Butyl	Nitrile	Neoprene	Hypalon	EPDM	Viton	XLPE	PTFE/TFE/FEF	Silicone
	Napthenic Acid	D	D	C	D	D	D	D	A	B	A
Natural Gas Contact Titan Tech	See Ammonia										
Neatsfoot Oil	D	D	B	A	B	B	B	A	A	A	-
Neu-Tri (Trichloroethylene)	D	D	D	C	D	D	D	A	B	A	-
Nickel Acetate	D	D	A	D	D	D	B	D	A	A	-
Nickel Chloride	A	A	A	A	A	A	A	A	A	A	A
Nickel Nitrate	A	A	A	A	A	A	A	A	A	A	-
Nickel Plating Solution	A	D	B	B	C	B	B	A	A	A	-
Nickel Sulfate	A	A	A	A	A	A	A	A	A	A	A
Niter Cake	A	A	A	A	A	A	A	A	A	A	-
Nitric Acid, 10%	D	D	B	D	C	B	B	A	A	A	C
Nitric Acid, 20%	D	D	B	D	D	B	C	A	A	A	C
Nitric Acid, 30%	D	D	B	D	D	C	C	A	B	A	C
Nitric Acid, 30-70%	D	D	C	D	D	D	D	C	C	A	D
Nitric Acid, Red Fuming	D	D	D	D	D	D	D	D	D	A	-
Nitrobenzene	D	D	D	D	D	D	D	B	A	A	C
Nitrogen Gas	A	A	A	A	A	A	A	A	A	A	-
Nitrogen Tetroxide	D	D	D	D	D	D	D	D	D	A	-
Nitromethane	B	B	B	D	C	C	B	D	A	A	-
Nitropropane	C	C	A	D	C	C	B	D	A	A	-
Nitrous Oxide	A	A	A	A	A	A	A	A	A	A	-
Octadecanoic Acid	D	D	B	A	B	D	C	C	A	A	-
Octane	D	D	D	A	B	D	D	A	B	A	-
Octanol (Octyl Alcohol)	B	B	B	A	B	B	A	A	A	A	-
Octyl Acetate	D	D	A	D	D	B	D	A	A	A	-
Octyl Amine	See Ammonia										
Octyl Carbinol	A	A	A	A	A	A	A	B	A	A	-
Octylene Glycol	A	A	A	A	A	A	A	A	A	A	-
Oil, Astm #1	D	D	D	A	A	B	D	A	A	A	-
Oil, Astm #2	D	D	D	A	A	C	D	A	A	A	-
Oil, Astm #3	D	D	D	A	B	C	D	A	A	A	-
Oil, Petroleum	D	D	D	A	A	C	D	A	A	A	-
Oleic Acid	D	D	B	B	C	C	B	C	A	A	D
Oleum (Fuming Sulfuric Acid)	D	D	D	D	D	D	D	D	D	A	-
Olive Oil (Non F.D.A.)	D	D	B	A	B	B	B	A	A	A	-
Orthodichlorobenzene	D	D	D	D	D	D	D	A	B	A	-
Oxalic Acid	C	C	A	B	C	B	A	C	A	A	B
Oxygen, Cold	B	B	A	B	B	B	B	A	A	A	D
Oxygen, Hot	D	D	D	D	D	D	D	B	A	A	-
Ozone	D	C	B	D	B	A	A	A	A	A	-
P-Cymene	D	D	D	C	D	D	D	A	A	A	-
P-Dichlorobenzene	D	D	D	D	D	D	D	A	A	A	-
Paint Thinner (Duco)	D	D	D	D	D	D	D	C	A	A	-
Palm Oil	D	D	A	A	B	B	B	A	A	A	-
Palmitic Acid	D	D	B	A	B	B	B	A	B	A	D
Papermaker's Alum	A	A	A	A	A	A	A	A	A	A	-
Paradichlorobenzene	D	D	D	D	D	D	D	A	B	A	-
Paraffin	D	D	D	A	A	D	D	A	D	A	-
Paraformaldehyde	D	D	B	B	B	B	B	C	A	A	-
Peanut Oil	D	D	C	A	B	B	D	A	B	A	-
Pentane	D	D	A	A	B	D	A	A	B	A	-
Perchloric Acid	B	B	B	D	A	A	B	A	A	A	-
Perchloroethylene	D	D	D	C	D	D	D	A	B	A	C
Petrolatum	D	D	D	A	A	C	D	A	A	A	-

Material (All ratings are based on 70°F)	Natural Rubber	SBR	Butyl	Nitrile	Neoprene	Hypalon	EPDM	Viton	XLPE	PTFE/TFE/FEF	Silicone
	Petroleum Ether (Naphtha)	D	D	D	A	A	D	D	A	A	A
Petroleum Oils	D	D	D	A	A	C	D	A	A	A	D
Petroleum, Crude	D	D	D	A	A	C	D	A	A	A	D
Phenol	C	C	B	D	C	C	C	A	A	A	-
Phenol Sulfonic Acid	D	D	C	D	C	D	C	A	B	A	-
Phenyl Chloride	D	D	D	D	D	D	D	A	A	A	-
Phenylhydrazine	C	D	B	D	D	C	C	A	A	A	-
Phorone	D	D	A	D	D	D	B	C	A	A	-
Phosphate Esters	D	D	A	D	D	D	A	C	A	A	-
Phosphoric Acid, 10%	A	A	A	A	A	A	A	A	A	A	C
Phosphoric Acid: 10-85%	C	C	A	C	B	A	A	A	A	A	C
Phosphorous Trichloride	D	D	A	D	D	D	A	A	A	A	-
Pickling Solution	C	C	C	C	C	C	C	B	A	A	-
Picric Acid, Molten	C	C	C	C	C	B	C	C	D	A	D
Picric Acid, Water Solution	A	C	A	B	B	A	B	C	A	A	-
Pine Oil	D	D	D	C	C	D	D	B	A	A	-
Pinene	D	D	D	A	D	D	D	A	A	A	-
Piperidine	D	D	D	D	D	D	D	D	B	A	-
Pitch	D	D	D	B	B	C	D	C	A	A	-
Plating Solution, Chrome	D	D	A	B	B	C	A	A	A	A	-
Plating Solutions, Others	A	A	A	B	B	C	A	B	A	A	-
Polyethylene Glycol	A	A	A	A	A	A	A	A	A	A	-
Polypropylene Glycol	A	A	A	A	A	A	A	A	A	A	-
Polyvinyl Acetate Emulsion (PVA)	C	C	A	C	B	B	A	C	A	A	-
Potassium Bicarbonate	A	A	A	A	A	A	A	A	A	A	-
Potassium Bisulfate	A	A	A	A	A	A	A	A	A	A	-
Potassium Bisulfite	A	A	A	A	A	A	A	A	A	A	-
Potassium Carbonate	A	A	A	A	A	A	A	A	A	A	-
Potassium Chloride	A	A	A	A	A	A	A	A	A	A	-
Potassium Chromate	D	D	A	D	C	C	B	A	B	A	-
Potassium Cyanide	A	A	A	A	A	A	A	A	A	A	A
Potassium Dichromate	D	D	A	D	B	C	B	A	A	A	-
Potassium Hydrate	A	B	A	B	B	B	A	C	A	A	-
Potassium Hydroxide	A	A	A	A	B	A	A	D	A	A	C
Potassium Nitrate	A	A	A	A	A	A	A	A	A	A	-
Potassium Permanganate	D	D	A	D	D	D	A	A	A	A	-
Potassium Silicate	A	A	A	A	A	A	A	A	A	A	-
Potassium Sulfate	A	A	A	A	A	A	A	A	A	A	A
Potassium Sulfide	A	A	A	A	A	A	A	A	A	A	-
Potassium Sulfite	A	A	A	A	A	A	A	A	A	A	-
Producer Gas	D	D	D	A	B	B	D	A	A	A	-
Propane Gas	Use Butane Propane Hose Only										
Propanediol	A	A	A	A	B	A	B	A	A	A	-
Propyl Acetate	D	D	B	D	D	D	B	D	A	A	-
Propyl Alcohol (Propanol)	A	A	A	A	A	A	A	A	A	A	-
Propyl Aldehyde	C	D	B	D	D	D	B	D	A	A	-
Propyl Chloride	D	D	C	D	C	D	C	B	B	A	-
Propylene Diamine	See Ammonia										
Propylene Dichloride	D	D	D	D	D	D	D	B	B	A	-
Propylene Glycol	A	A	A	A	A	A	A	A	A	A	-
Pydraul Hydraulic Fluids	D	D	B	D	D	D	B	A	B	A	-
Pyranol	D	D	D	C	D	D	D	A	A	A	-
Pyridine	D	D	B	D	D	D	B	D	A	A	-
Pyroigneous Acid	C	C	B	C	B	B	B	A	A	A	-

Rating Codes: **A** = Excellent, **B** = Good, **C** = Fair Conditional, **D** = Unsatisfactory, (-) = No Data Available

Elastomeric Chemical Resistance

Material (All ratings are based on 70°F)	Natural Rubber										
	SBR	Butyl	Nitrile	Neoprene	Hypalon	EPDM	Viton	XLPE	PTFE/TFE/FEP	Silicone	
Pyrrrole	C	B	B	D	D	D	C	C	A	A	-
Rape Seed Oi	D	D	A	B	B	B	B	A	B	A	-
Red Oil (Crude Oleic Acid)	D	D	B	B	B	B	B	A	A	A	-
Richfield A Weed Killer, 100%	D	D	D	D	D	D	D	C	B	A	-
Richfield B Weed Killer, 33%	D	D	B	B	B	C	D	C	B	A	-
Rosin Oil	D	D	D	A	A	B	D	A	A	A	-
Rotenone and Water	A	A	A	A	A	A	A	A	A	A	-
Rum	F.D.A. Tube Required										
Sal Ammoniac (Ammonium Chloride)	A	A	A	A	A	A	A	A	A	A	-
Salicylic Acid	A	B	A	D	D	A	A	A	A	A	-
Salt Water (Sea Water)	A	A	A	A	A	A	A	A	A	A	-
Sewage	C	C	C	A	B	A	B	A	A	A	B
Silicate Esters	D	D	D	B	A	A	D	A	A	A	-
Silicate of Soda (Sodium Silicate)	A	A	A	A	A	A	A	A	A	A	-
Silicone Greases	A	A	A	A	A	A	A	A	A	A	-
Silicone Oils	A	A	A	A	A	A	A	A	A	A	-
Silver Nitrate	A	A	A	A	A	A	A	A	A	A	-
Skelly Solvent	D	D	D	A	B	C	D	A	A	A	-
Skydrol Hydraulic Fluids	D	D	A	D	D	D	A	D	A	A	-
Soap Solutions	A	A	A	A	A	A	A	A	A	A	A
Soda Ash (Sodium Carbonate)	A	A	A	A	A	A	A	A	A	A	A
Soda Niter (Sodium Nitrate)	A	A	A	A	A	A	A	A	A	A	-
Soda, Caustic (Sodium Hydroxide)	A	B	A	B	A	A	A	D	A	A	-
Soda, Lime	A	B	A	B	B	B	A	C	A	A	-
Sodium Acetate	D	A	D	D	D	B	D	A	A	A	-
Sodium Aluminate	A	A	A	A	A	A	A	A	A	A	-
Sodium Bicarbonate	A	A	A	A	A	A	A	A	A	A	A
Sodium Bisulfate	A	A	A	A	A	A	A	A	A	A	A
Sodium Bisulfite	A	A	A	A	A	A	A	A	A	A	-
Sodium Borate	A	A	A	A	A	A	A	A	A	A	-
Sodium Carbonate	A	A	A	A	A	A	A	A	A	A	-
Sodium Chloride	A	A	A	A	A	A	A	A	A	A	A
Sodium Chromate	D	D	A	D	C	C	B	C	B	A	-
Sodium Cyanide	A	A	A	A	A	A	A	A	A	A	A
Sodium Dichromate	D	D	A	D	C	C	B	C	A	A	-
Sodium Fluoride	A	A	A	A	A	A	A	A	A	A	-
Sodium Hydroxide	A	B	A	B	A	A	A	D	A	A	A
Sodium Hypochlorite	C	D	B	D	D	C	B	A	B	A	B
Sodium Metaphosphate	A	A	A	A	B	B	A	A	A	A	A
Sodium Nitrate	A	A	A	A	A	A	A	A	A	A	D
Sodium Nitrite	A	A	A	A	A	A	A	A	A	A	-
Sodium Perborate	C	D	A	D	D	D	B	A	A	A	B
Sodium Peroxide	B	B	A	B	B	B	A	A	B	A	C
Sodium Phosphate	A	A	A	A	A	A	A	A	A	A	D
Sodium Silicate	A	A	A	A	A	A	A	A	A	A	A
Sodium Sulfate	A	A	A	A	A	A	A	A	A	A	A
Sodium Sulfide	A	A	A	A	A	A	A	A	A	A	A
Sodium Sulfite	A	A	A	A	A	A	A	A	A	A	-
Sodium Thiosulfate	A	A	A	A	A	A	A	A	A	A	-
Soybean Oil	D	D	B	B	B	B	B	A	A	A	A
Stannic Chloride	A	A	B	A	A	A	A	A	A	A	B
Stannic Sulfide	A	A	A	A	A	A	A	A	A	A	-
Stannous Chloride	A	A	A	A	A	A	A	A	A	A	B
Stannous Sulfide	A	A	A	A	A	A	A	A	A	A	-

Material (All ratings are based on 70°F)	Natural Rubber										
	SBR	Butyl	Nitrile	Neoprene	Hypalon	EPDM	Viton	XLPE	PTFE/TFE/FEP	Silicone	
Steam, over 300°F	Steam Hose Only										
Steam, under 300°F	Steam Hose Only										
Stearic Acid	D	D	B	A	B	B	C	A	A	B	A
Stoddard's Solvent	D	D	D	A	C	D	D	A	A	B	-
Styrene	D	D	D	D	D	D	D	B	A	B	-
Sugar Sols. (Sucrose, Non F.D.A.)	A	A	A	A	A	A	A	A	A	A	-
Sulfamic Acid	C	C	A	B	B	B	A	A	A	A	-
Sulfite Liquors	B	B	A	B	B	A	B	A	A	A	-
Sulfonic Acid	D	D	D	D	C	C	D	D	B	C	-
Sulfur (Molten)	D	D	B	C	C	C	C	A	D	D	B
Sulfur Chloride	D	D	D	D	B	B	C	A	B	C	C
Sulfur Dioxide	C	C	B	D	B	B	C	A	A	B	B
Sulfur Hexafluoride	A	A	A	A	A	A	A	A	A	A	-
Sulfur Trioxide	D	D	B	D	D	D	C	A	B	B	-
Sulfuric Acid, 25%	D	D	D	D	B	A	A	A	A	A	D
Sulfuric Acid, 25-50%	B	D	A	D	C	B	B	A	A	A	D
Sulfuric Acid, Fuming	D	D	D	D	D	D	D	D	D	D	D
Sulfurous Acid	B	C	B	C	B	A	B	A	A	A	D
Tall Oil	D	D	D	C	D	D	D	A	A	B	-
Tallow	D	D	D	A	A	D	D	A	A	B	-
Tannic Acid	A	B	A	C	B	B	A	A	A	A	B
Tar	D	D	D	B	B	D	D	A	D	A	B
Tartaric Acid	A	A	A	A	B	A	A	A	A	A	A
Terpineol	D	D	C	D	D	D	C	A	B	A	-
Tertiary Butyl Alcohol	A	A	A	A	A	A	A	A	A	A	-
Tetrachlorobenzene	D	D	D	D	D	D	D	B	B	A	-
Tetrachloroethane	D	D	D	D	D	D	D	A	B	A	-
Tetrachloroethylene	D	D	D	D	D	D	D	A	B	A	-
Tetrachloromethane	D	D	D	C	D	D	D	A	B	A	-
Tetrachloronaphthalene	D	D	D	D	D	D	D	A	B	A	-
Tetraethyl Lead	D	D	D	B	C	D	D	A	A	A	-
Tetraethylene Glycol	A	A	A	A	A	A	A	A	A	A	-
Tetrahydrofuran (THF)	D	D	D	D	D	D	D	D	A	A	-
Thionyl Chloride	D	D	D	D	D	D	D	B	A	A	-
Tin Chloride	A	A	A	A	A	A	A	A	A	A	-
Tin Tetrachloride	A	A	A	A	A	A	A	A	A	A	-
Titanium Tetrachloride	D	D	D	B	C	C	C	C	A	A	-
Toluene (Toluol)	D	D	D	D	D	D	D	A	A	A	D
Toluene Diisocyanate (TDI)	C	C	A	C	D	D	A	B	A	A	-
Toxaphene	D	D	D	B	B	D	D	A	A	A	-
Transformer Oils (Chlorinated Phenyl Base Askereles)	D	D	D	D	D	D	A	A	B	A	-
Transformer Oils (Petroleum Base)	D	D	D	A	B	B	D	A	A	A	-
Transmission Fluids-A	D	D	D	B	C	D	D	A	A	A	-
Transmission Fluids-B	D	D	D	C	D	D	D	A	A	A	-
Tributyl Amine	See Ammonia										
Tributyl Phosphate	D	D	B	D	D	D	B	B	A	A	-
Tricetin	A	B	A	B	B	B	A	D	A	A	-
Trichlorobenzene	D	D	D	D	D	D	D	B	B	A	-
Trichloroethane	D	D	D	D	D	D	D	A	A	A	-
Trichloroethylene	D	D	D	C	D	D	D	A	B	A	D
Trichloropropane	D	D	D	D	D	D	D	A	A	A	-
Tricresyl Phosphate (TCP)	D	D	A	D	D	D	B	B	A	A	-
Triethanolamine (TEA)	See Ammonia										

Rating Codes: **A** = Excellent, **B** = Good, **C** = Fair Conditional, **D** = Unsatisfactory, (-) = No Data Available

Elastomeric Chemical Resistance

Material (All ratings are based on 70°F)	Natural Rubber	SBR	Butyl	Nitrile	Neoprene	Hypalon	EPDM	Viton	XLPE	PTFE/TFE/PEP	Silicone
Trichloroethylene	D	D	D	C	D	D	D	A	B	A	-
Trichloropropane	D	D	D	D	D	D	D	A	A	A	-
Tricresyl Phosphate (TCP)	D	D	A	D	D	D	B	B	A	A	-
Triethanolamine (TEA)	See Ammonia										
Triethylamine	See Ammonia										
Triethylene Glycol	A	A	A	A	A	A	A	A	A	A	-
Trinitrotoluene (TNT)	D	D	D	D	B	B	D	B	D	A	-
Triphenyl Phosphate	D	D	A	D	C	C	B	C	A	A	-
Trisodium Phosphate	A	A	A	A	A	A	A	A	A	A	-
Tung Oil	D	D	C	A	B	B	D	A	A	A	-
Turbine Oil	D	D	D	B	B	B	D	A	A	A	-
Turpentine	D	D	D	B	B	D	D	A	A	A	D
2,4D With 10% Fuel Oil	D	D	D	A	A	D	D	A	A	A	-
Ucon Hydrolube Oils	D	D	A	A	B	D	A	A	A	A	-
Undecanol	A	A	A	A	A	A	A	B	A	A	-
Unsymmetrical Dimethyl											
Hydrazine (UDMH)	D	D	A	D	D	A	A	D	A	A	-
Uran	B	C	B	B	B	A	B	C	A	A	-
Urea	See Ammonia										
V.M.& P. Naptha	D	D	D	A	A	D	D	A	A	A	-
Varnish	D	D	D	B	B	C	D	A	A	A	-
Vegetable Oils	D	D	A	A	B	B	A	A	A	A	-
Versilube	A	A	A	A	A	A	A	A	A	A	-

Material (All ratings are based on 70°F)	Natural Rubber	SBR	Butyl	Nitrile	Neoprene	Hypalon	EPDM	Viton	XLPE	PTFE/TFE/PEP	Silicone
Vinegar	A	C	A	C	A	A	B	B	A	A	A
Vinyl Acetate	D	D	A	D	D	C	C	D	B	A	D
Vinyl Benzene	D	D	D	D	D	D	D	A	B	A	-
Vinyl Chloride (Monomer)	C	D	D	D	D	D	D	A	A	A	-
Vinyl Ether	D	D	D	D	D	C	C	D	A	A	-
Vinyl Toluene	D	D	D	D	D	D	D	A	B	A	-
Vinyl Trichloride	D	D	D	D	D	D	D	A	A	A	-
Water Spray	D	D	D	B	B	D	D	A	A	A	-
Water, Fresh (Non F.D.A.)	A	A	A	A	A	A	A	A	A	A	A
Water, Salt	A	A	A	B	A	A	A	A	A	A	-
Whiskey, Wines											
White Liqueur	A	A	B	A	A	A	C	A	A	A	-
White Oil	D	D	D	A	B	D	D	A	A	A	-
Wood Alcohol (Methanol)	A	A	A	A	A	A	D	A	D	A	-
Xylene (Xy101)	D	D	D	D	D	D	D	A	A	A	D
Xylidine	D	D	D	D	D	D	D	C	B	A	-
Zeolites	A	A	A	A	A	A	A	A	A	A	-
Zinc Acetate	C	D	A	C	C	C	B	D	A	A	-
Zinc Carbonate	A	A	A	A	A	A	A	A	A	A	-
Zinc Chloride	A	A	A	A	A	A	B	A	A	A	A
Zinc Chromate	A	C	A	A	A	C	A	A	B	A	-
Zinc Sulfate	A	A	A	A	A	A	A	A	A	A	A

Elastomeric Temperature and Shelf Life

Elastomers & Fluoroplastics	Min. Material Temperature	Continuous Material Temperature	Intermittent Operating Temperature / Accumulative Time (hrs)**	Shelf Life (yrs)	Resistant To	Generally Attacked By
Chloroprene (CR)	-40°C (-40°F)	107°C (225°F)	121°C (250°F) / 168	36	Moderate Acids & Chemicals, Ozone, Oils, Fats & many Solvents	Oxidizing Acids, Esters & Ketones, Aromatic Chlorinated & Nitro Hydrocarbons
Chlorosulfinated Polyethylene (CSM)	-40°C (-40°F)	121°C (250°F)	177°C (350°F) / 70	60	Strong Acids, Freons, Hydroxides, Ozone, Alcohols, Alkalines & Hydrochlorite Solutions	Ketones, Esters, Some Chlorinated Oxidizing Acids, Chlorinated Nitro & Aromatic Hydrocarbons
Ethylene Propylene Diene Monomer (EPDM)	-54°C (-65°F)	149°C (300°F)**	163°C (325°F) / 300 177°C (350°F) / 200 177°C (350°F) / 150 191°C (375°F) / 70	60	Vegetable & Animal Fats, Oils, Ozone, Ketones, Alcohols, Many Strong & Oxidizing Chemicals	Mineral Oils, Solvents & Aromatic Hydrocarbons
Chlorobutyl (CIIR)	-40°C (-40°F)	149°C (300°F)	177°C (350°F) / 150	32	Vegetable & Animal Oils, Fats, Greases, Air, Gas, Water & Many Oxidizing Chemicals	Oils, Solvents & Aromatic Hydrocarbons
Fluoroelastomer (FKM)	-34°C (-30°F)	204°C (400°F)	288°C (550°F) / 240 316°C (600°F) / 48 343°C (650°F) / 16 371°C (700°F) / 4* 399°C (750°F) / 2*	49	All Aromatic Aliphatic & Halogenated Hydrocarbons, Vegetable & Animal Oils, Many Acids	Ketones, Esters & Nitro Containing Compounds
Silicone (SL)	-51°C (-60°F)	249°C (480°F)	315°C (600°F) / 168	60	Oxidizing Chemicals, Ozone, Concentrated Sodium Hydroxide	Many Solvents, Oils, Concentrated Acids, Sulfurs
Polytetra Fluoroethylene (PTFE)	-79°C (-110°F)	315°C (600°F)	371°C (700°F) / 75	Unlimited	Most Known Fluid Chemicals	Molten Alkali Metals, Fluorine & Related Compounds
Nitrile-Buna Rubber (NBR)	-40°C (-40°F)	107°C (225°F)	121°C (250°F) / 168	15	Most Hydrocarbons, Fats, Oils, Greases, Hydraulic Fluids, Chemicals & Solvents	Ozone, Ketones, Esters, Aldehydes, Nitro & Chlorinated Hydrocarbons, Polar Solvents MEK.
Hydrogenated Nitrile Butadiene Rubber (HNBR)	-54°C (-65°F)	149°C (300°F)	163°C (325°F) / 300	36	Mineral Oil Based Hydraulic Fluids, Animal & Vegetable Fats, Diesel Fuel, Ozone, Sour Gas, Dilute Acids	Aromatic Oils, Polar Solvents, Some Oxygenated Solvents & Aromatic Hydrocarbons

*Fluoroelastomers when reinforced with non-reactive materials have an intermittent temperature capacity of 4 hours at 371°C (700°F) and 2 hours at 399°C (750°F) | ** Excursions at high temperature will have a detrimental effect on useful life of the product | *** Using a Peroxide cure, continuous material temperature is 165°C (329°F)

Elastomeric Comparative Properties

ANSI/ASTM D1418-77	NR/IR	AU/EU	CR	NBR	CIIR	CSM	EPDM	FKM	AFMU	SI
Elastomer	Gum/Natural	Urethane	Neoprene	Nitrile/Buna-N	Chlorobutyl	Hypalon®	EPDM/EPT	Viton®/Fluorel®	PTFE	Silicone
ASTM D-2000, SAE J-200	AA	BG	BC-BE	BF-BG-BK-CH	AA-BA	CE	BA-CA-DA	HK	-	FC-FE-GE
Military: MIL STD 417	RN	SB	SC	SB	RS	SC	RS	-	-	TA
Chemical Name Definition	Polyisoprene	Polyester/Polyether Urethane	Poly-Chloroprene	Butadiene Acrylic-Nitrile	Chloro-Isobutylene Isoprene	Chloro-Sulfonated Polyethylene	Ethylene Propylene Polymer	Fluoronated Hydrocarbon	Tetrafluoro-Ethylene Resin	Poly-Siloxane
Abrasion	A	A	A	B	B	A	A	B	B	D
Absorption, Water	A	B	B	B	A	A	A	A	-	A
Acid-Concentrated	B	D	B	B	B	A	A	A	A	C
Acid-Diluted	B	C	A	B	A	A	A	A	A	A
Adhesion To Fabrics	A	A	A	B	B	B	B	A	B	A
Adhesion To Metals	A	A	A	A	B	A	A	B	B	A
Chemicals	B	C	B	B	A	A	A	A	A	A
Cold	A	A	B	B	B	B	A	B	A	A
Dielectric Strength	A	A	B	D	A	A	A	B	-	B
Dynamic Properties	A	A	C	A	C	C	A	A	-	D
Electrical Insulation	A	C	B	D	B	B	A	B	-	A
Flame	D	C	B	D	D	B	D	A	A	B
Heat	B	B	A	B	A	A	A	A	A	A
Heat Aging	C	B	B	B	A	A	A	A	A	A
Hydrocarbons-Aliphatic	D	A	B	A	D	B	D	A	A	D
Hydrocarbons-Aromatic	D	B	C	B	D	C	D	A	A	D
Hydrocarbons-Oxygenated	B	D	D	D	B	D	A	D	A	C
Impermeability	D	D	D	D	D	D	D	D	-	D
Oil-Animal & Vegetable	D	A	B	A	A	B	B	A	A	A
Oil & Gasoline	D	A	B	A	D	B	D	A	A	C
Oxydation	B	A	A	B	A	A	A	A	A	A
Ozone	C	A	A	C	A	A	A	A	A	A
Radiation	A	A	A	A	B	A	A	A	B	A
Rebound-Cold	A	B	A	B	D	B	A	B	-	A
Rebound-Hot	A	B	A	B	A	B	A	B	-	A
Set-Compression	B	C	B	B	C	C	B	B	-	C
Solvents, Lacquer	D	D	D	C	B	D	D	D	A	D
Steam	C	D	C	B	B	C	A	B	-	C
Sunlight Aging	D	B	A	D	A	A	A	A	A	A
Swelling In Oil	D	A	B	A	D	A	D	A	-	C
Tear	A	A	B	C	B	C	B	C	-	D
Tensile Strength	A	A	B	A	B	C	A	A	-	D
Water	B	D	C	B	B	C	A	B	A	C
Weather	C	A	A	C	A	A	A	A	A	A
Generally Resistant To:	Water, air and average concentration acids, bases, alcohols, salts, ketones, best abrasion resistance	moderate chemicals, oils, fats, greases and many hydrocarbons	moderate acids and chemicals, ozone, oils, fats and many solvents. Oily abrasive applications	Most hydrocarbons, fats, oils, greases, hydraulic fluids, chemicals and solvents	animal and vegetable oils, fats, greases, air, gas, water, many oxidizing chemicals and ozone	strong acids, and bases, freons, hydroxides, ozone, alcohols, etching, alkaline and hypochlorite solutions	Vegetable and animal fats, oils, ozone, many strong and oxidizing chemicals, keytones and alcohols	All aromatic aliphatic and halogenated hydrocarbons, many acids, animal and vegetable oils	Most known fluid chemicals	Moderate or oxidizing chemicals, ozone, concentrated sodium hydroxide
Generally Affected Or Attacked By:	Not for ozone, strong acids, bases, oils, solvents, most hydrocarbons	Not for concentrated acids, ketones, esters, chlorinated and nitro hydrocarbons	Not for oxidizing acids, esters and ketones, aromatic, chlorinated and nitro hydrocarbons	Not for ozone, ketones, esters, aldehydes, nitro and chlorinated hydrocarbons, polar solvents, MEK	Not for oils, solvents, aromatic hydrocarbons	Not for ketones, esters, certain chlorinated oxidizing acids, chlorinated, nitro and aromatic hydrocarbons	Not for mineral oils, solvents, aromatic hydrocarbons	Not for ketones, esters, and nitro containing compounds	Not for molten alkali metals, fluorine and related compounds	Not for many-solvents, oils, concentrated acids, sulfurs

Rating Codes: **A** = Excellent, **B** = Good, **C** = Fair Conditional, **D** = Unsatisfactory, (-) = No Data Available
 © Fluorel is a Registered Trademark of 3M Companies. Viton, Hypalon are Registered Trademarks of E.I. Du Pont de Nemours & Co. Inc.

Thermoplastic Chemical Resistance

Material	Hose Construction								
	PVC		TPR		TPE		TPU		UHMW
	68°F	104°F	68°F	104°F	68°F	104°F	68°F	104°F	
Acetaldehyde	D	D	D	D	D	D	D	D	B
Acetaldehyde (40%)	D	D	D	D	D	D	D	D	B
Acetate Solvents, crude	D	D	C	D	C	D	C	D	-
Acetate Solvents, pure	D	D	C	D	C	D	C	D	-
Acetate Solvents, pure	A	B	A	B	C	D	D	D	-
Acetic Acid (20-30%)	A	B	A	B	C	D	D	D	B
Acetic Acid (80%)	B	B	A	B	D	D	D	D	B
Acetic Acid Vapors	A	B	A	B	C	C	D	D	-
Acetic Acid Glacial	B	C	B	C	D	D	D	D	-
Acetic Anhydride	D	D	-	-	-	-	D	D	B
Acetone	B	C	A	A	C	D	C	D	A
Acetylene	A	A	-	-	-	-	A	A	A
Acrylonitrile	A	B	-	-	-	-	-	-	-
Adipic Acid	B	C	-	-	-	-	D	D	-
Allyl Alcohol (96%)	D	D	-	-	-	-	D	D	A
Allyl Chloride	C	C	-	-	-	-	D	D	B
Alum	A	A	A	A	A	A	A	A	A
Aluminum Acetate	B	C	-	-	-	-	-	-	A
Aluminum Alkyl	D	D	-	-	-	-	-	-	-
Aluminum Chloride	A	A	A	A	A	A	C	C	A
Aluminum Fluoride	A	A	A	A	A	A	A	A	A
Aluminum Hydroxide	A	-	A	A	B	B	B	C	A
Aluminum Nitrate	A	B	-	-	-	-	A	A	A
Aluminum Oxychloride	A	A	-	-	-	-	-	-	-
Aluminum Phosphate Solution	D	D	-	-	-	-	-	-	-
Aluminum Salts	A	A	-	-	-	-	-	-	-
Aluminum Sulphate	A	A	A	A	A	A	A	A	A
Aminoethanol	B	-	-	-	-	-	-	-	-
Ammonia - aqueous	A	-	A	-	C	-	C	D	-
Ammonia - dry gas	C	D	B	-	C	-	C	D	-
Ammonia - liquid	D	D	C	-	C	-	C	D	-
Ammoniated Latex	A	C	-	-	-	-	-	-	-
Ammonium Acetate	A	A	-	-	-	-	-	-	-
Ammonium Bicarbonate	A	A	-	-	-	-	-	-	-
Ammonium Carbonate	A	A	-	-	-	-	A	A	-
Ammonium Chloride Solution	A	A	-	-	-	-	B	C	A
Ammonium Fluoride (25%)	D	D	-	-	-	-	C	D	-
Ammonium Hydroxide (30% NH)	A	A	-	-	-	-	B	B	A
Ammonium Metaphosphate	A	A	-	-	-	-	B	B	-
Ammonium Persulfate	A	A	-	-	-	-	B	B	-
Ammonium Nitrate	A	A	-	-	-	-	-	-	A
Ammonium Phosphate Solutions	A	A	-	-	-	-	A	A	A
Ammonium Sulfate	A	A	A	A	A	A	A	A	A
Ammonium Sulfide	A	A	A	A	B	B	B	B	-
Ammonium Thiocyanate	D	D	-	-	-	-	-	-	-
Amyl Acetate	A	B	A	B	D	D	D	D	A
Amyl Alcohol	D	D	D	D	D	D	-	-	A
Amyl Chloride	B	C	A	B	-	-	D	D	A
Aniline	D	D	-	-	-	-	D	D	A
Aniline Chlorohydrate	D	D	-	-	-	-	D	D	-
Aniline Hydrochloride	A	-	-	-	-	-	-	-	-
Animal Gelatin	A	A	A	A	-	-	-	-	-
Animal Oils	D	D	-	-	-	-	-	-	-
Ant Oil	A	A	-	-	-	-	-	-	-
Anthraquinone	A	A	-	-	-	-	-	-	-

Material	Hose Construction								
	PVC		TPR		TPE		TPU		UHMW
	68°F	104°F	68°F	104°F	68°F	104°F	68°F	104°F	
Anthraquinonesulfonic Acid	A	A	-	-	-	-	D	D	-
Antifreeze	A	A	-	-	-	-	-	-	-
Antimony Chloride	A	-	-	-	-	-	-	-	-
Antimony Salts	A	-	-	-	-	-	-	-	-
Antimony Trichloride	A	A	-	-	-	-	A	A	-
Apple Sauce/Juice	A	A	-	-	-	-	-	-	-
Aqua Ammonia	D	D	-	-	-	-	-	-	-
Aqua Regia	C	D	B	C	-	-	D	D	D
Argon, Compressed	D	D	-	-	-	-	-	-	A
Aromatic Hydrocarbons	C	C	A	A	-	-	-	-	-
Arsenic Acid 80%	A	B	A	A	D	D	D	D	-
Arsenic Trichloride	A	A	-	-	-	-	A	A	-
Arsenic Trioxide	A	-	-	-	-	-	-	-	-
Arylsulfonic Acid	C	D	-	-	-	-	D	D	-
Askarel (Transformer Oil)	D	D	-	-	-	-	-	-	-
Asphalt	D	D	-	-	-	-	-	-	D
ASTM Fuel Oil # 1	A	A	A	A	B	B	A	A	A
ASTM Oil # 2	D	D	-	-	-	-	-	-	A
ASTM Fuel Oil # 3	B	C	A	A	B	B	A	A	A
ASTM Fuel A	B	B	A	A	B	B	A	A	B
ASTM Fuel B	D	D	A	A	B	C	B	C	B
ASTM Fuel C	D	D	-	-	-	-	B	C	B
Baby Food	A	A	-	-	-	-	-	-	-
Baltic (Types 100, 150, 200, 300, 500)	B	-	-	-	-	-	-	-	-
Barium Carbonate	A	A	A	A	A	A	A	A	-
Barium Chloride	A	A	A	A	A	A	A	A	A
Barium Hydroxide	A	A	-	-	-	-	B	C	A
Barium Sulfate	A	A	A	A	A	A	A	A	-
Barium Sulfide	A	A	A	A	A	A	A	A	A
Barley	A	D	-	-	-	-	-	-	-
Basic Copper Arsenate	A	-	-	-	-	-	-	-	-
Beer	A	A	-	-	-	-	-	-	A
Beet Sugar - liquor	A	A	-	-	-	-	-	-	B
Bellows 80-20 Hydraulic Oil	B	-	-	-	-	-	-	-	-
Benzaldehyde	D	D	-	-	-	-	-	-	-
Benzene	D	D	-	-	-	-	-	-	B
Benzidine	D	D	-	-	-	-	-	-	-
Benzoic Acid	B	C	A	B	D	D	D	D	-
Benzoic Aldehyde	D	D	-	-	-	-	-	-	-
Benzol	D	D	B	C	C	D	C	D	B
Benzotrithloride	D	D	-	-	-	-	-	-	B
Benzyl Alcohol	A	-	-	-	-	-	-	-	A
Benzyl Chloride	D	D	-	-	-	-	-	-	A
Berries	A	A	-	-	-	-	-	-	-
Bismuth Carbonate	A	A	-	-	-	-	A	A	-
Black Liquor	A	A	A	A	-	-	-	-	-
Blast Furnace Gas	D	D	-	-	-	-	-	-	-
Bleach (12.5% Active CL)	B	C	A	B	C	D	C	D	A
Borax	A	B	A	A	-	-	A	A	A
Bordeaux Mixture	A	A	A	A	-	-	-	-	-
Boric Acid	A	A	A	A	-	-	D	D	A
Boric Oxide	A	-	-	-	-	-	-	-	-
Boron Trifluoride	A	A	-	-	-	-	A	A	-
Brake Fluid (Petroleum Base)	B	-	-	-	-	-	-	-	-
Brake Fluid (Synthetic Base)	B	-	-	-	-	-	-	-	-

Rating Codes: **A** = Excellent, **B** = Good, **C** = Fair Conditional, **D** = Unsatisfactory, (-) = No Data Available

Thermoplastic Chemical Resistance

Material	Hose Construction								UHMW
	PVC		TPR		TPE		TPU		
	68°F	104°F	68°F	104°F	68°F	104°F	68°F	104°F	
Brine	A	A	A	A	C	D	B	C	A
Bromic Acid	A	B	A	B	C	D	D	D	-
Bromine - Liquid	D	D	C	D	D	D	D	D	-
Bromine - Water	D	D	C	D	D	D	D	D	-
Bromobenzene	D	D	-	-	-	-	-	-	C
Bromochloromethane	D	D	-	-	-	-	-	-	-
Bromotoluene	D	D	-	-	-	-	-	-	-
Bunker Oil	D	D	-	-	-	-	-	-	-
Butadiene	C	D	-	-	-	-	-	-	-
Butane	A	A	A	A	A	A	A	A	A
Butanol - Primary	D	D	-	-	-	-	C	D	A
Butanol - Secondary	D	D	-	-	-	-	C	D	A
Butter	B	C	-	-	-	-	-	-	-
Butyl Acetate	A	-	-	-	-	-	-	-	A
Butyl Alcohol	A	B	A	B	A	B	C	D	A
Butyl Cellosolve	D	D	C	D	-	-	-	-	A
Butyl Mercaptan	D	D	-	-	-	-	-	-	-
Butyl Phenol	C	D	B	C	-	-	-	-	-
Butyl Stearate	A	-	-	-	-	-	-	-	A
Butylene	A	B	A	A	A	A	A	A	-
Butyric Acid 20%	C	D	B	C	C	D	C	D	A
Butynedial	D	D	-	-	-	-	D	D	-
Cake Alum Solution	A	-	-	-	-	-	-	-	-
Calcium Arsenate	A	-	-	-	-	-	-	-	-
Calcium Bisulfate	A	A	A	A	A	A	-	-	-
Calcium Bisulfide	B	-	-	-	-	-	-	-	-
Calcium Bisulfite	A	A	-	-	-	-	A	A	-
Calcium Carbonate	A	A	A	A	A	A	A	A	-
Calcium Chlorate	A	A	A	A	B	C	B	C	-
Calcium Chloride	A	A	A	A	C	D	C	D	A
Calcium Hydrosulfide	B	-	-	-	-	-	-	-	-
Calcium Hydroxide	A	A	A	A	B	C	B	C	A
Calcium Hypochlorite	A	A	A	A	D	D	D	D	C
Calcium Metasilicate	A	-	-	-	-	-	-	-	-
Calcium Nitrate	A	A	A	A	A	A	A	A	A
Calcium Silicate	A	-	-	-	-	-	-	-	-
Calcium Sulfate	A	A	A	A	A	A	A	A	-
Calcium Sulfide	B	-	-	-	-	-	-	-	A
Cane Sugar Liquors	-	-	-	-	-	-	-	-	-
Carbolic Acid	D	D	-	-	-	-	-	-	A
Carbon Bisulfide	A	A	-	-	-	-	-	-	-
Carbon Dioxide	A	A	-	-	-	-	-	-	A
Carbon Disulfide	D	D	-	-	-	-	-	-	A
Carbon Monoxide	A	A	A	A	A	A	A	A	A
Carbon Tetrachloride	D	D	B	C	C	D	C	D	B
Carbolic Acid	D	D	-	-	-	-	-	-	-
Carbonic Acid	A	A	A	A	D	D	D	D	-
Carrots	A	A	A	A	D	D	-	-	-
Casein	A	B	-	-	-	-	A	A	-
Castor Oil	A	A	A	A	A	A	A	A	A
Catsup	A	B	-	-	-	-	-	-	-
Caustic Potash	A	A	A	A	C	D	C	D	-
Caustic Soda	A	A	A	A	C	D	C	D	-
Cellosolve	C	D	B	C	B	C	B	C	A
Cellulose Acetate	A	-	-	-	-	-	-	-	-

Material	Hose Construction								UHMW
	PVC		TPR		TPE		TPU		
	68°F	104°F	68°F	104°F	68°F	104°F	68°F	104°F	
Cellulose Buty	A	-	-	-	-	-	-	-	-
Cheese	A	B	-	-	-	-	-	-	-
Cherries	A	A	-	-	-	-	-	-	-
China-Wood Oil	B	-	-	-	-	-	-	-	-
Chlorodane	B	-	-	-	-	-	-	-	-
Chloroacetic Acid	A	D	-	-	-	-	D	D	A
Chloral Hydrate	A	A	-	-	-	-	B	C	-
Chloric Acid 20%	A	A	-	-	-	-	D	D	-
Chlorinated Hydrocarbons	A	A	-	-	-	-	D	D	-
Chlorinated Solvents	D	D	-	-	-	-	-	-	-
Chlorine Gas - dry	A	A	A	A	D	D	D	D	-
Chlorine Gas - moist	C	D	B	C	C	D	D	D	-
Chlorine Trifluoride	D	D	-	-	-	-	-	-	-
Chloroacetyl Chloride	A	-	-	-	-	-	-	-	-
Chlorobenzene	D	D	-	-	-	-	-	-	-
Chlorobromomethane	D	D	-	-	-	-	-	-	-
Chloroethane	D	D	-	-	-	-	-	-	-
Chloroform	D	D	-	-	-	-	-	-	A
Chloropentane	D	D	-	-	-	-	-	-	A
Chloropicrin Mixture	D	D	-	-	-	-	-	-	-
Chlorotoluene	D	D	-	-	-	-	-	-	B
Chlorox	A	-	-	-	-	-	-	-	B
Chlorsulfonic Acid	C	D	-	-	-	-	D	D	D
Chocolate	B	C	-	-	-	-	-	-	-
Chocolate Syrup	A	-	-	-	-	-	-	-	-
Chromic Chloride	A	-	-	-	-	-	-	-	-
Chrome Alum	A	A	A	A	A	A	A	A	-
Chromic Acid 25%	B	C	A	B	D	D	D	D	A
Chromic Acid 50%	B	C	A	B	D	D	D	D	A
Chromium Trioxide	D	D	-	-	-	-	-	-	-
Cider	B	-	-	-	-	-	-	-	-
Citgo FR Fuels	B	-	-	-	-	-	-	-	-
Coal Gas	A	-	-	-	-	-	-	-	-
Coal Tar	D	D	C	C	-	-	D	D	A
Coconut Oil	C	D	A	A	A	A	A	A	A
Cola Beverage	A	A	-	-	-	-	-	-	-
Copper Chloride	A	B	A	A	A	A	A	A	A
Copper Cyanide	A	A	-	-	-	-	-	-	A
Copper Flouride 2%	A	A	-	-	-	-	A	A	-
Copper Nitrate	A	B	A	A	A	A	A	A	-
Copper Sulphate	A	B	-	-	-	-	A	A	A
Core Oils	A	A	-	-	-	-	-	-	-
Corn Oils	A	B	-	-	-	-	-	-	A
Cottonseed Oil	B	C	-	-	-	-	A	A	A
Creosole	D	D	C	D	C	D	-	-	A
Creosote	D	D	C	D	-	-	-	-	A
Cresylic Acid 50%	D	D	-	-	-	-	D	D	A
Crude Oil Sour	A	A	A	A	A	A	A	A	A
Crude Oil Sweet	A	A	A	A	A	A	A	A	A
Crude Wax	A	-	-	-	-	-	-	-	-
Cupric Chloride	A	-	-	-	-	-	-	-	-
Cupric Cyanide	A	-	-	-	-	-	-	-	-
Cupric Nitrate	A	-	-	-	-	-	-	-	A
Cupric Sulfate	A	-	-	-	-	-	-	-	A
Cyanide, Copper	A	-	-	-	-	-	-	-	-

Rating Codes: **A** = Excellent, **B** = Good, **C** = Fair Conditional, **D** = Unsatisfactory, (-) = No Data Available

Thermoplastic Chemical Resistance

Material	Hose Construction								
	PVC		TPR		TPE		TPU		UHMW
	68°F	104°F	68°F	104°F	68°F	104°F	68°F	104°F	
Cyanide, Silver	A	-	-	-	-	-	-	-	-
Cyanide Sodium	A	-	-	-	-	-	-	-	-
Cyclohexane	D	D	-	-	-	-	-	-	A
Cyclohexanol	D	D	-	-	-	-	C	D	A
Cyclohexanone	D	D	-	-	-	-	D	D	-
Cymene	D	D	-	-	-	-	-	-	-
Decanol	D	D	-	-	-	-	-	-	-
Deicing Fluid	A	A	-	-	-	-	-	-	-
Demineralized Water	A	A	A	A	C	D	B	D	-
Denatured Alcohol	A	-	-	-	-	-	-	-	-
Detergents, synthetic	A	B	A	A	-	-	-	-	-
Developers, photographic	A	A	A	A	-	-	-	-	-
Dextrin	A	-	-	-	-	-	-	-	-
Dextron	B	-	-	-	-	-	-	-	-
Dextrose	A	B	A	A	A	A	A	A	-
Diacetone	D	D	-	-	-	-	-	-	-
Diacetone Alcohol	D	D	-	-	-	-	-	-	A
Diammonium Phosphate	A	-	-	-	-	-	-	-	-
Diazinon	B	-	-	-	-	-	-	-	-
Diazo Salts	A	A	-	-	-	-	-	-	-
Dibutyl Phthalate	A	-	-	-	-	-	-	-	A
Dibutylamine	D	D	-	-	-	-	-	-	A
Dichlorobenzene	D	D	-	-	-	-	-	-	A
Dichlorobenzyl Chloride	D	D	-	-	-	-	-	-	-
Dichloroethane	D	D	-	-	-	-	-	-	-
Dichloroethylene	D	D	-	-	-	-	-	-	-
Dichloromethane	D	D	-	-	-	-	-	-	-
Diesel Oils	C	D	A	B	-	-	-	-	A
Diethanolamine	B	-	-	-	-	-	-	-	A
Diethyl Ether	B	-	-	-	-	-	-	-	-
Diethyl Ketone	D	D	-	-	-	-	-	-	-
Diethyl Oxalate	D	D	-	-	-	-	-	-	-
Diethylene Dioxide	B	-	-	-	-	-	-	-	-
Diethylene Ether	D	D	-	-	-	-	-	-	-
Diethylene Glycol	A	-	-	-	-	-	-	-	A
Diglycolic Acid	A	B	-	-	-	-	-	-	-
Dihydroxyethyl Ether	A	-	-	-	-	-	-	-	-
Dimethylamine	D	D	-	-	-	-	D	D	A
Dimethylbenzene	D	D	-	-	-	-	-	-	-
Dimethylcarbonal	B	-	-	-	-	-	-	-	A
Dimethylketone	D	D	-	-	-	-	-	-	A
Diocetyl Phthalate	D	D	-	-	-	-	-	-	A
Diocetyl Phosphite	D	D	-	-	-	-	-	-	A
Dioxane	D	D	-	-	-	-	-	-	A
Disodium Phosphate	A	A	A	A	A	A	A	A	A
Distilled Water	A	A	A	A	C	D	B	D	-
DMB (Dimethylbenzene)	D	D	-	-	-	-	-	-	-
Duro Oils	B	-	-	-	-	-	-	-	-
EDB (Ethylene Dibromide)	D	D	-	-	-	-	-	-	-
Eggs	A	A	-	-	-	-	-	-	-
Emulsions, photographic	A	A	-	-	-	-	-	-	-
Enamels	B	-	-	-	-	-	-	-	-
Essential Oils	B	-	-	-	-	-	-	-	-
Ethanolamine	B	-	-	-	-	-	-	-	A
Ethers	D	D	-	-	-	-	B	C	-

Material	Hose Construction								
	PVC		TPR		TPE		TPU		UHMW
	68°F	104°F	68°F	104°F	68°F	104°F	68°F	104°F	
Ethyl Acetate	D	D	-	-	-	-	-	-	A
Ethyl Acrylate	D	D	-	-	-	-	-	-	A
Ethyl Alcohol	B	C	-	-	-	-	-	-	A
Ethyl Alcohol 50-98%	C	D	-	-	-	-	-	-	A
Ethyl Bromide	D	D	-	-	-	-	-	-	-
Ethyl Chloride	D	D	D	D	D	D	D	D	B
Ethyl Ether	D	D	-	-	-	-	B	C	A
Ethyl Ether Acetate	A	-	-	-	-	-	-	-	-
Ethyl Mercaptan	D	D	-	-	-	-	-	-	-
Ethyl Methyl Ketone	D	D	-	-	-	-	-	-	-
Ethylbutanol	A	-	-	-	-	-	-	-	-
Ethylbutyl Alcohol	A	-	-	-	-	-	-	-	-
Ethylene Bromide	A	D	A	C	D	D	D	D	-
Ethylene Chlorohydrin	D	D	-	-	-	-	-	-	-
Ethylene Dibromide	D	D	-	-	-	-	-	-	B
Ethylene Dichloride	D	D	-	-	-	-	D	D	B
Ethylene Glycol	A	A	A	A	B	C	B	C	A
Ethylene Oxide	D	D	-	-	-	-	D	D	-
Ethylhexanol	A	-	-	-	-	-	-	-	-
Ethylhexyl Acrylate	D	D	-	-	-	-	-	-	-
Ethylhexyl Alcohol	A	-	-	-	-	-	-	-	-
Fatty Acid	B	-	-	-	-	-	-	-	A
Fatty Alcohol, Blend	A	-	-	-	-	-	-	-	-
Ferric Chloride	A	A	A	A	B	C	B	C	A
Ferric Nitrate	A	A	A	A	A	A	A	A	A
Ferric Sulphate	A	A	A	A	A	A	A	A	A
Ferrous Chloride	A	A	-	-	-	-	A	A	A
Ferrous Nitrate	B	-	-	-	-	-	-	-	-
Ferrous Sulfate Solution	A	-	-	-	-	-	-	-	A
Fertilizer	B	-	-	-	-	-	-	-	-
Figs	A	A	-	-	-	-	-	-	-
Fish Solubles	A	A	-	-	-	-	-	-	-
Fixing Solutions, photographic	A	B	-	-	-	-	-	-	-
Flour	A	D	-	-	-	-	-	-	-
Fluoroboric Acid	A	A	A	A	A	A	-	-	C
Fluorine	D	D	-	-	-	-	D	D	D
Fluosilic Acid	D	D	-	-	-	-	-	-	C
Foric Acid	A	C	-	-	-	-	D	D	-
Formaldehyde Solution (to 50%)	A	-	-	-	-	-	-	-	A
Formalin	A	-	-	-	-	-	-	-	-
Formic Acid 3%	A	B	-	-	-	-	-	-	A
Formic Acid 10%	A	B	-	-	-	-	D	D	A
Formic Acid 25%	A	B	-	-	-	-	D	D	A
Formic Acid 50%	C	D	-	-	-	-	D	D	A
Freon-12	A	B	A	A	A	A	A	A	-
Fructose	A	A	A	A	A	A	A	A	-
Fruit Pulp and Juices	A	A	-	-	-	-	A	A	-
Fuel Oil	B	C	A	A	A	B	A	A	A
Fumaric Acid	D	D	-	-	-	-	-	-	-
Furan	D	D	-	-	-	-	-	-	-
Furfural	D	D	-	-	-	-	D	D	A
Furfuryl Alcohol	A	C	-	-	-	-	-	-	A
Fusel Oil	A	-	-	-	-	-	-	-	-
Gallic Acid Solution	D	D	-	-	-	-	-	-	A
Gasohol	D	D	-	-	-	-	-	-	-

Rating Codes: **A** = Excellent, **B** = Good, **C** = Fair Conditional, **D** = Unsatisfactory, (-) = No Data Available

Thermoplastic Chemical Resistance

Material	Hose Construction								UHMW
	PVC		TPR		TPE		TPU		
	68°F	104°F	68°F	104°F	68°F	104°F	68°F	104°F	
Gas - cook oven	B	B	A	B	B	B	B	B	
Gas - natural (dry)	A	A	A	A	A	A	A	A	
Gas - natural (wet)	A	A	A	A	A	A	A	A	
Gasoline	D	D	-	-	-	-	-	-	A
Gasoline - refined	C	D	A	A	B	C	-	-	
Gasoline, Unleaded	D	D	-	-	-	-	-	-	
Gasoline, White	D	D	-	-	-	-	-	-	
Gelatin	A	A	A	A	A	A	A	A	
Gin	A	B	-	-	-	-	-	-	
Ginger Ale	A	A	-	-	-	-	-	-	
Glacial Acetic Acid	D	D	-	-	-	-	-	-	
Glucose	A	A	A	A	A	A	A	A	A
Glue	A	-	-	-	-	-	-	-	
Glycerine	A	A	A	A	A	A	-	-	
Glycerol	A	A	-	-	-	-	-	-	
Glycol	A	A	A	A	B	B	A	A	A
Glycolic Acid 30%	A	A	-	-	-	-	D	D	
Grape Juice	A	A	-	-	-	-	-	-	
Grapefruit Juice	A	A	-	-	-	-	-	-	
Grease	A	-	-	-	-	-	-	-	A
Green Liquor (paper)	A	A	-	-	-	-	-	-	A
Heptachlor	D	D	-	-	-	-	-	-	
Heptane	C	D	A	B	A	-	A	-	A
Heptanol	A	-	-	-	-	-	-	-	A
Hexane	C	D	-	-	-	-	-	-	B
Honey	A	A	-	-	-	-	-	-	
HPO (Sodium Thiosulfate)	A	-	-	-	-	-	-	-	
Hydraulic Fluid	A	-	-	-	-	-	-	-	A
Hydraulic Fluid HF-18, HF-20	B	-	-	-	-	-	-	-	
Hydrazine	D	D	-	-	-	-	-	-	
Hydro-Drive Oil (houghton)	B	-	-	-	-	-	-	-	
Hydrobromic Acid	D	D	-	-	-	-	-	-	B
Hydrochloric Acid 10%	A	A	A	A	D	D	D	D	A
Hydrochloric Acid 48%	C	D	-	-	-	-	D	D	A
Hydrocyanic Acid	D	D	-	-	-	-	-	-	A
Hydrofluoric Acid 4%	B	C	-	-	-	-	D	D	A
Hydrofluoric Acid 10%	C	C	-	-	-	-	D	D	A
Hydrofluoric Acid 48%	C	D	-	-	-	-	D	D	A
Hydrofluoric Acid 60%	C	D	-	-	-	-	D	D	A
Hydrofluosilicic Acid	D	D	-	-	-	-	D	D	B
Hydrogen	A	B	A	A	A	A	A	A	A
Hydrogen Bromide (Dry) (liquid)	-	-	-	-	-	-	D	D	
Hydrogen Cyanide	A	A	-	-	-	-	D	D	
Hydrogen Peroxide	D	D	-	-	-	-	-	-	A
Hydrogen Peroxide 12%	A	B	A	A	B	C	-	-	A
Hydrogen Peroxide 50%	A	C	A	B	C	D	B	C	A
Hydrogen Peroxide 90%	D	D	C	D	D	D	D	D	A
Hydrogen Phosphide	A	C	-	-	-	-	-	-	
Hydrogen Sulfide - Aqueous Sol.	A	A	-	-	-	-	-	-	A
Hydrogen Sulfide - Dry	A	A	-	-	-	-	-	-	
Hydrolube (water glycol)	A	A	-	-	-	-	-	-	
Hydrolubric Oil	B	-	-	-	-	-	-	-	
Hydroquinone Solution	B	-	-	-	-	-	-	-	
Hydroxylamine Sulfate	A	A	-	-	-	-	-	-	
Hypochlorous Acid	A	A	-	-	-	-	C	D	

Material	Hose Construction								UHMW
	PVC		TPR		TPE		TPU		
	68°F	104°F	68°F	104°F	68°F	104°F	68°F	104°F	
Iodine	D	D	-	-	-	-	-	-	B
Iron Acetate Liquor	A	-	-	-	-	-	-	-	
Iron Salts	A	-	-	-	-	-	-	-	
Iron Sulfate Solution	A	-	-	-	-	-	-	-	
Isobutanol	B	-	-	-	-	-	-	-	
Isobutyl Alcohol	B	-	-	-	-	-	-	-	
Isooctane	D	D	-	-	-	-	-	-	A
Isopropanol	B	-	-	-	-	-	-	-	
Isopropyl Acetate	D	D	-	-	-	-	-	-	A
Isopropyl Alcohol	A	B	A	A	C	D	-	-	A
Isopropyl Ether	D	D	-	-	-	-	-	-	A
JP 3, 4, 5	D	D	B	C	C	C	B	C	
Jelly	A	A	-	-	-	-	-	-	
Jet Fuel - All Types	D	D	-	-	-	-	-	-	A
Karo Syrup	A	A	-	-	-	-	-	-	
Kerosene	D	D	A	A	A	A	A	B	A
Ketones	D	D	-	-	-	-	-	-	A
Kraft Liquor (paper)	A	A	-	-	-	-	-	-	
Lacquer Thinner	C	D	B	B	C	C	B	-	B
Lactic Acid 28%	A	A	-	-	-	-	D	D	
Lard	B	C	-	-	-	-	-	-	B
Lard Oil	A	B	-	-	-	-	A	B	
Latex Paint	A	-	-	-	-	-	-	-	
Lauric Acid	A	A	A	A	C	D	C	D	
Lauryl Chlorite	A	A	-	-	-	-	A	B	
Lauryly Sulfate	A	A	-	-	-	-	-	-	
Lead Acetate	A	A	A	A	A	A	A	A	A
Lead Nitrate Solution	A	-	-	-	-	-	-	-	
Lead, Tetraethyl	A	-	-	-	-	-	-	-	
Lemon Juice	A	B	-	-	-	-	-	-	
Ligroin	D	D	-	-	-	-	-	-	
Lime, Chloronated	B	-	-	-	-	-	-	-	
Lime, sulfur	A	A	-	-	-	-	-	-	A
Linoleic Acid	A	-	-	-	-	-	-	-	
Linseed Oil	A	A	A	A	A	A	A	A	A
Liquid Soap	B	-	-	-	-	-	-	-	
Liquors	A	B	-	-	-	-	-	-	
Lubricating Oils	D	D	A	A	A	A	A	A	
Machine Oil under 135°F	B	-	-	-	-	-	-	-	
Magnesium Carbonate	A	A	A	A	A	A	A	A	
Magnesium Hydroxide	A	A	A	A	C	D	B	C	A
Magnesium Nitrate	A	A	-	-	-	-	A	A	
Magnesium Sulfate Solution	A	-	-	-	-	-	-	-	A
Malathion	A	-	-	-	-	-	-	-	
Maleic Acid Solution	D	D	-	-	-	-	-	-	A
Manganese Salts	A	-	-	-	-	-	-	-	
Manganese Sulfate Solution	A	-	-	-	-	-	-	-	
Mayonnaise	A	A	-	-	-	-	-	-	
MBK (Methyl Butyl Ketone)	D	D	-	-	-	-	-	-	
MEA (Ethanalamine)	B	-	-	-	-	-	-	-	
MEK (Ethyl Methyl Ketone)	D	D	-	-	-	-	-	-	
Mercuric Chloride	B	B	A	A	B	C	B	C	
Mercuric Chloride Solution	B	-	-	-	-	-	-	-	
Mercuric Cyanide	B	B	-	-	-	-	-	-	
Mercuric Nitrate	B	B	-	-	-	-	B	B	

Rating Codes: **A** = Excellent, **B** = Good, **C** = Fair Conditional, **D** = Unsatisfactory, (-) = No Data Available

Thermoplastic Chemical Resistance

Material	Hose Construction								
	PVC		TPR		TPE		TPU		UHMW
	68°F	104°F	68°F	104°F	68°F	104°F	68°F	104°F	
Mercury	B	B	-	-	-	-	-	-	A
Mesitylene	D	D	-	-	-	-	-	-	-
Mesityl Oxide	D	D	-	-	-	-	-	-	A
Mesitylene	D	D	-	-	-	-	-	-	-
Methanol	D	D	D	D	D	D	D	D	-
Methyl Acetate	D	D	-	-	-	-	-	-	A
Methyl Acetone	A	-	-	-	-	-	-	-	A
Methyl Alcohol	C	D	B	C	C	D	D	D	A
Methyl Bromide	D	D	-	-	-	-	-	-	B
Methyl Butanethiol	D	D	-	-	-	-	-	-	-
Methyl Butanol	A	-	-	-	-	-	-	-	-
Methyl Chloride	D	D	-	-	-	-	D	D	-
Methyl Chloroform	D	D	-	-	-	-	-	-	-
Methyl Cyanide	A	-	-	-	-	-	-	-	-
Methyl Ethyl Ketone	D	D	B	C	C	D	-	-	A
Methyl Isobutenyl Ketone	D	D	-	-	-	-	-	-	-
Methyl Isobutyl Ketone	D	D	-	-	-	-	-	-	-
Methyl Isopropyl Ketone	D	D	-	-	-	-	-	-	-
Methyl Methacrylate	A	-	-	-	-	-	-	-	B
Methyl Methacrylate Monomer	D	D	-	-	-	-	-	-	-
Methyl Propyl Ketone	D	D	-	-	-	-	-	-	-
Methyl Slaicylate	A	-	-	-	-	-	-	-	-
Methyl Sulfate	A	-	-	-	-	-	-	-	-
Methylamine	D	D	-	-	-	-	-	-	-
Methylaniline	D	D	-	-	-	-	-	-	-
Methylene Bromide	D	D	-	-	-	-	-	-	-
Methylene Chloride	D	D	-	-	-	-	-	-	B
Methylene Dichloride	D	D	-	-	-	-	-	-	-
Milk	A	A	-	-	-	-	A	A	-
Mineral Oils	A	B	A	A	A	A	A	A	A
Molasses	A	A	A	A	A	A	A	A	-
Monochlorobenzene	D	D	-	-	-	-	-	-	B
Monomethylamine	D	D	-	-	-	-	-	-	-
Monosodium Phosphate	A	-	-	-	-	-	-	-	-
Motor Oil	C	-	-	-	-	-	-	-	-
Muriatic Acid	D	D	-	-	-	-	-	-	A
N-Octane	D	D	-	-	-	-	-	-	-
Naphthenic Acid	A	-	-	-	-	-	-	-	-
Naptha	D	D	A	A	-	-	-	-	A
Napthalene	C	D	A	A	-	-	-	-	A
Nickel Chloride Solution	A	A	-	-	-	-	A	A	A
Nickel Nitrate Solution	B	-	-	-	-	-	A	A	A
Nickel Plating Solution	D	D	-	-	-	-	-	-	-
Nickel Salts	B	-	-	-	-	-	-	-	-
Nickel Sulfate Solution	A	-	-	-	-	-	-	-	A
Nicotine	A	A	-	-	-	-	A	A	-
Nicotine Acids	A	B	A	A	C	D	C	D	-
Nicotine Salts	A	-	-	-	-	-	-	-	-
Niter Cake	A	-	-	-	-	-	-	-	-
Nitric Acid 10%	A	B	-	A	D	D	D	D	A
Nitric Acid 40%	B	C	A	A	D	D	D	D	A
Nitric Acid 60%	C	D	B	C	D	D	D	D	A
Nitric Acid 68%	C	D	B	C	D	D	D	D	A
Nitric Acid 70%	D	D	C	C	D	D	D	D	A
Nitrobenzene	D	D	-	-	-	-	D	D	A

Material	Hose Construction								
	PVC		TPR		TPE		TPU		UHMW
	68°F	104°F	68°F	104°F	68°F	104°F	68°F	104°F	
Nitrogen	A	-	-	-	-	-	-	-	A
Nitrogen Oxide	D	D	-	-	-	-	-	-	A
Nitromethane	D	D	-	-	-	-	-	-	-
Nitrous Acid (up to 10%)	A	-	-	-	-	-	-	-	-
Nitrous Oxide	A	A	-	-	-	-	A	A	-
Oats	A	D	-	-	-	-	-	-	-
Octadecanoic Acid	A	-	-	-	-	-	-	-	-
Octanol	B	-	-	-	-	-	-	-	A
Octyl Alcohol	B	-	-	-	-	-	-	-	A
Oil of Turpentine	A	-	-	-	-	-	-	-	-
Oils, Animal	B	-	-	-	-	-	-	-	-
Oils, Mineral	D	D	-	-	-	-	-	-	-
Oils, Petroleum	A	B	A	A	A	A	A	A	A
Oleic Acid	B	C	A	A	D	D	D	D	A
Oleum	D	D	D	D	D	D	D	D	D
Olive Oil	B	B	-	-	-	-	-	-	B
Ortho-Dichlorobenzene	D	D	-	-	-	-	-	-	-
Ortho-xylene	D	D	-	-	-	-	-	-	-
Oxalic Acid	D	D	-	-	-	-	-	-	A
Oxygen	A	A	-	-	-	-	A	A	-
Ozone	C	D	-	-	-	-	-	-	C
Paint	A	-	-	-	-	-	-	-	-
Para formaldehyde	A	B	-	-	-	-	-	-	-
Paraffin	A	B	-	-	-	-	-	-	A
Palmitic Acid 10%	A	B	-	-	-	-	D	D	A
Palmitic Acid 70%	C	D	-	-	-	-	D	D	A
Peaches	A	A	-	-	-	-	-	-	-
Peanut Butter	A	B	-	-	-	-	-	-	-
Peanut Oil	B	-	-	-	-	-	-	-	-
Peas	A	A	-	-	-	-	-	-	-
Pentachlorophenol in Oil	D	D	-	-	-	-	-	-	-
Pentane	C	D	-	-	-	-	-	-	B
Pentanone	D	D	-	-	-	-	-	-	-
Pentasol	B	-	-	-	-	-	-	-	-
Perchloric acid	D	D	-	-	-	-	-	-	-
Perchloroethylene	D	D	-	-	-	-	-	-	-
Petrol	D	D	-	-	-	-	-	-	-
Petroleum Ether	C	C	A	A	-	-	-	-	-
Petroleum Naptha	D	D	-	-	-	-	-	-	-
Petroleum Oils (Refined)	A	-	-	-	-	-	-	-	-
Petroleum Oils (Sour)	B	-	-	-	-	-	-	-	-
Phenol	D	D	-	-	-	-	-	-	A
Phenol Acid	D	D	-	-	-	-	-	-	-
Phenyl Chloride	D	D	-	-	-	-	-	-	-
Phenylhydrazine	D	D	-	-	-	-	-	-	-
Phenylhydrazine Hydrochloride	C	D	-	-	-	-	-	-	-
Phosgene (gas)	A	B	-	-	-	-	-	-	-
Phosgene (liquid)	D	D	-	-	-	-	-	-	-
Phosphorous (yellow)	B	C	-	-	-	-	-	-	-
Phosphorous Pentoxide	D	D	-	-	-	-	-	-	-
Phosphorous Trichloride	A	A	-	-	-	-	A	A	-
Phosphorous Trichloride	A	A	-	-	-	-	A	A	-
Photographic Chemicals	A	A	-	-	-	-	A	B	-
Photographic Fixing Solutions	A	-	-	-	-	-	-	-	-
Picric Acid	D	D	D	D	D	D	D	D	-

Rating Codes: **A** = Excellent, **B** = Good, **C** = Fair Conditional, **D** = Unsatisfactory, (-) = No Data Available

Thermoplastic Chemical Resistance

Material	Hose Construction								UHMW
	PVC		TPR		TPE		PTU		
	68°F	104°F	68°F	104°F	68°F	104°F	68°F	104°F	
Pinene	D	D	-	-	-	-	-	-	A
Pitch	B	C	A	A	-	-	-	-	
Plating Solutions	A	B	-	-	-	-	A	A	
Polyethylene Glycol	B	-	-	-	-	-	-	-	
Potash	A	-	-	-	-	-	-	-	A
Potassium Acetate	A	-	-	-	-	-	-	-	
Potassium Acid Sulfate	A	A	-	-	-	-	A	A	
Potassium Antimonate	A	A	-	-	-	-	A	A	
Potassium Bicarbonate	A	A	A	A	A	A	A	A	
Potassium Bichromate	A	A	-	-	-	-	A	A	
Potassium Bisulfate	A	-	-	-	-	-	-	-	A
Potassium Bisulfite	A	A	-	-	-	-	A	A	A
Potassium Borate 1%	A	A	-	-	-	-	A	A	
Potassium Bisulfate	A	-	-	-	-	-	-	-	
Potassium Bromate 10%	A	A	A	A	A	A	A	A	
Potassium Bromide	A	A	A	A	A	A	A	A	
Potassium Carbonate	A	-	-	-	-	-	-	-	A
Potassium Chlorate	A	-	-	-	-	-	-	-	
Potassium Chloride	A	A	A	A	A	B	A	B	A
Potassium Chromate	A	-	-	-	-	-	B	B	B
Potassium Cuprocyanide	A	-	-	-	-	-	-	-	
Potassium Cyanide	A	A	A	A	A	A	A	A	A
Potassium Dichromate	A	A	-	-	-	-	B	B	B
Potassium Ferrocyanide	A	A	-	-	-	-	A	A	
Potassium Fluoride	A	A	A	A	A	B	-	-	
Potassium Hydrate	B	-	-	-	-	-	-	-	
Potassium Hydroxide	A	A	-	-	-	-	-	-	B
Potassium Hypochlorite	B	C	-	-	-	-	D	D	
Potassium Iodide	A	-	-	-	-	-	-	-	
Potassium Nitrate	A	A	A	A	A	A	A	A	A
Potassium Perborate	A	A	A	A	A	A	A	A	
Potassium Perchlorite	A	A	-	-	-	-	B	C	
Potassium Permanganate	D	D	-	-	-	-	-	-	A
Potassium Persulfate	A	-	-	-	-	-	-	-	
Potassium Sulfate	A	-	-	-	-	-	-	-	A
Potassium Sulfide	A	A	A	A	A	A	A	A	A
Potassium Sulfite	B	-	-	-	-	-	-	-	
Potassium Thiosulfate	A	-	-	-	-	-	-	-	
Potatoes	A	A	-	-	-	-	-	-	
Propane	A	A	A	A	A	A	A	A	
Propargyl Alcohol	A	A	-	-	-	-	-	-	
Propyl Alcohol	A	B	A	A	B	C	B	C	A
Propylene Dichloride	D	D	-	-	-	-	D	D	
Propylene Glycol	A	-	-	-	-	-	D	D	A
Prune Juice	A	A	-	-	-	-	-	-	
Puropale RX Oils	B	-	-	-	-	-	-	-	
Pyrene	D	D	-	-	-	-	-	-	
Pyrethrum	B	-	-	-	-	-	-	-	
Pyridine	D	D	-	-	-	-	-	-	
Pyrogard C, D	B	-	-	-	-	-	-	-	
Red Oil	B	-	-	-	-	-	-	-	
Regal Oils R&O	B	-	-	-	-	-	-	-	
Richfield A Weed Killer	A	B	-	-	-	-	-	-	
Rubilene Oils	B	-	-	-	-	-	-	-	
Salicylic Acid	A	-	-	-	-	-	-	-	

Material	Hose Construction								UHMW
	PVC		TPR		TPE		TPU		
	68°F	104°F	68°F	104°F	68°F	104°F	68°F	104°F	
Salt Water	A	A	A	A	B	C	B	D	A
Sauerkraut	B	-	-	-	-	-	-	-	
Selenic Acid	A	B	-	-	-	-	D	D	
Sewage	B	-	-	-	-	-	-	-	A
Shortening	B	C	-	-	-	-	-	-	
Silicic Acid	A	A	-	-	-	-	D	D	
Silicone Greases	B	-	-	-	-	-	-	-	
Silicone Oils	B	-	-	-	-	-	-	-	A
Silver Cyanide	A	A	-	-	-	-	A	A	
Silver Nitrate	A	A	A	A	A	A	-	-	A
Silver Plating Solution	A	B	A	A	A	A	A	A	
Skydrol 500A & 7000	D	D	-	-	-	-	-	-	
Soap	A	A	A	A	B	C	B	D	
Soda Ash	A	-	-	-	-	-	-	-	A
Soda Water	A	A	-	-	-	-	-	-	
Sodium Acetate	A	A	-	-	-	-	A	A	A
Sodium Aluminate Solution	B	-	-	-	-	-	-	-	A
Sodium Arsenite	A	A	-	-	-	-	A	A	
Sodium Benzoate	A	B	A	A	A	A	A	A	
Sodium Bicarbonate	A	A	A	A	A	A	A	A	A
Sodium Bichromate Solution	B	-	-	-	-	-	-	-	
Sodium Bisulfite	A	-	-	-	-	-	-	-	A
Sodium Borate	A	-	-	-	-	-	-	-	A
Sodium Bromide	A	A	A	A	A	B	A	B	
Sodium Carbonate (soda ash)	A	A	A	A	A	A	A	A	A
Sodium Chlorate	B	C	A	B	C	C	B	B	
Sodium Chloride	A	A	A	A	A	B	A	B	A
Sodium Chlorite Solution	B	-	-	-	-	-	-	-	
Sodium Chromate	B	-	-	-	-	-	-	-	
Sodium Cyanide	A	A	A	A	A	A	A	A	A
Sodium Dichromate	A	B	A	B	A	B	A	B	A
Sodium Ferricyanide	A	A	-	-	-	-	A	A	
Sodium Ferrocyanide	A	A	-	-	-	-	A	A	
Sodium Fluoride (70%)	A	A	-	-	-	-	A	B	
Sodium Hydrate	B	-	-	-	-	-	-	-	
Sodium Hydrochlorite	B	-	-	-	-	-	-	-	
Sodium Hydrosulfide	A	-	-	-	-	-	-	-	
Sodium Hydrosulfite	B	-	-	-	-	-	-	-	
Sodium Hydroxide 10%	A	A	A	A	C	D	C	D	A
Sodium Hydroxide 35%	A	B	A	A	D	D	D	D	A
Sodium Hydroxide 50%	A	C	A	B	-	-	-	-	A
Sodium Hypochlorite (20%)	A	A	-	-	-	-	D	D	A
Sodium Hyposulfate	A	-	-	-	-	-	-	-	
Sodium Metaphosphate	A	-	-	-	-	-	-	-	A
Sodium Nitrate	A	A	-	-	-	-	A	A	A
Sodium Nitrite	A	A	-	-	-	-	A	A	
Sodium Peroxide	A	-	-	-	-	-	-	-	A
Sodium Phosphate	A	-	-	-	-	-	-	-	A
Sodium Phosphate Acid	B	B	A	B	D	D	-	-	
Sodium Silicate	A	-	-	-	-	-	-	-	A
Sodium Sulfate	A	-	-	-	-	-	-	-	A
Sodium Sulfhydrylate	B	-	-	-	-	-	-	-	
Sodium Sulfide	A	A	-	-	-	-	A	A	
Sodium Sulfite	A	A	-	-	-	-	A	A	A
Sodium Sulphrydate	B	-	-	-	-	-	-	-	

Rating Codes: **A** = Excellent, **B** = Good, **C** = Fair Conditional, **D** = Unsatisfactory, (-) = No Data Available

Thermoplastic Chemical Resistance

Material	Hose Construction								
	PVC		TPR		TPE		TPU		UHMW
	68°F	104°F	68°F	104°F	68°F	104°F	68°F	104°F	
Sodium Thiosulfat	A	A	-	-	-	-	A	B	A
Solnus Oils	A	-	-	-	-	-	-	-	-
Sour Crude Oil	D	D	-	-	-	-	-	-	-
Soya Beans	A	D	-	-	-	-	-	-	-
Soya Oil	A	C	-	-	-	-	-	-	-
Soybean Oil	A	A	-	-	-	-	-	-	A
Spent Acid	D	D	-	-	-	-	-	-	-
Spinach	A	A	-	-	-	-	-	-	-
Squash	A	A	-	-	-	-	-	-	-
Stannic Chloride	B	-	-	-	-	-	-	-	A
Stannis Chloride	A	A	A	A	A	B	A	B	-
Starch	A	-	-	-	-	-	-	-	-
Starch Gum	A	-	-	-	-	-	-	-	-
Stearic Acid	A	-	-	-	-	-	-	-	A
Stoddard Solvent	B	-	-	-	-	-	-	-	-
Straight Synthetic Oils	B	-	-	-	-	-	-	-	-
Styrene	D	D	-	-	-	-	-	-	B
Sugar - all forms	A	A	-	-	-	-	-	-	-
Sulfamic Acid	D	D	-	-	-	-	-	-	-
Sulfate Liquors under 150°F	A	-	-	-	-	-	-	-	-
Sulfur	B	B	-	-	-	-	-	-	A
Sulfur Chloride	B	-	-	-	-	-	-	-	A
Sulfur Dioxide (dry)	A	-	-	-	-	-	-	-	B
Sulfur Dioxide (liquid)	D	D	-	-	-	-	-	-	B
Sulfur Hexafluoride (Gas)	B	-	-	-	-	-	-	-	-
Sulfur Trioxide	A	-	-	-	-	-	-	-	D
Sulfuric Acid 10%	A	B	A	A	C	D	C	D	A
Sulfuric Acid 70%	A	B	A	A	D	D	D	D	A
Sulfuric Acid 95%	C	C	A	B	D	D	D	D	A
Sulfurous Acid	B	C	A	B	D	D	D	D	A
Sulfur Dioxide Gas - dry	A	A	-	-	-	-	-	-	B
Sulfur Dioxide Gas - wet	D	D	-	-	-	-	-	-	B
Sulfur Dioxide - Liquid	C	D	-	-	-	-	-	-	B
Sun R&O Oils	B	-	-	-	-	-	-	-	-
Suntac HP Oils	B	-	-	-	-	-	-	-	-
Suntac WR Oils	B	-	-	-	-	-	-	-	-
Sunvis Oils 700, 800, 900	B	-	-	-	-	-	-	-	-
Synthetic Oil (Citgo)	B	-	-	-	-	-	-	-	-
Tall Oil	D	D	-	-	-	-	-	-	A
Tallow	B	-	-	-	-	-	-	-	A
Tannic Acid	A	A	A	A	C	D	C	D	A
Tanning Liquors	A	A	-	-	-	-	-	-	-
Tar Oil	B	-	-	-	-	-	-	-	-
Tartaric Acid	A	B	A	A	B	C	C	D	-
TEA (Triethanolamine)	B	C	-	-	-	-	-	-	-
Tellus Oils	B	-	-	-	-	-	-	-	-
Tenol Oils	B	-	-	-	-	-	-	-	-
Terpineol	B	-	-	-	-	-	-	-	-
Tetrachloroethane	D	D	-	-	-	-	-	-	-
Tetraethyl Lead	C	D	-	-	-	-	-	-	-
Tetrahydrofuran	D	D	-	-	-	-	-	-	-
Tetrahydrodicyclopentadiene	D	D	-	-	-	-	-	-	-
THF (Tetrahydrofuran)	D	D	-	-	-	-	-	-	-
Thionyl Chloride	D	D	-	-	-	-	D	D	-
Tin Chloride	A	A	A	A	A	A	-	-	-

Material	Hose Construction								
	PVC		TPR		TPE		TPU		UHMW
	68°F	104°F	68°F	104°F	68°F	104°F	68°F	104°F	
Titanium Tetrachloride	A	D	-	-	-	-	C	D	B
Toluene	D	D	B	B	C	D	-	-	A
Toluol	D	D	-	-	-	-	-	-	-
Tomatoes	A	A	-	-	-	-	-	-	-
Tributyl Phosphate	D	D	-	-	-	-	-	-	A
Trichloroethylene	D	D	-	-	-	-	C	D	B
Trichloroethane	D	D	-	-	-	-	-	-	-
Tricresyl Phosphate	D	D	-	-	-	-	D	D	A
Triethanolamine	C	D	-	-	-	-	-	-	A
Triethylamine	B	C	-	-	-	-	-	-	A
Trihydroxybenzoic Acid	D	D	-	-	-	-	-	-	-
Trimethylbenzene	D	D	-	-	-	-	-	-	-
Trimethyl Propane	C	D	-	-	-	-	-	-	-
Trinitrophenol	A	-	-	-	-	-	-	-	-
Trisodium Phosphate	A	A	A	A	A	A	A	A	-
Tung Oil	B	-	-	-	-	-	-	-	A
Turpentine	C	D	A	A	B	C	A	B	-
Ucon Hydrolube 150CP, 200CP	B	-	-	-	-	-	-	-	-
Ucon Hydrolube 275CP,300CP, 550CP	B	-	-	-	-	-	-	-	-
Ucon M1	B	-	-	-	-	-	-	-	-
Union Hydraulic Tractor Fluid	B	-	-	-	-	-	-	-	-
Urea	A	B	A	A	A	A	A	A	A
Urine	A	A	A	A	A	A	A	A	-
Varnish	D	D	A	A	A	B	A	B	-
Vegetable Oils	B	C	-	-	-	-	-	-	A
Versilube F-50, F-44	B	-	-	-	-	-	-	-	-
Vinegar	A	B	-	-	-	-	B	C	D
Vinyl Acetate	D	D	-	-	-	-	D	D	A
Vinyl Chloride	D	D	-	-	-	-	-	-	A
Vinyl Trichloride	D	D	-	-	-	-	-	-	A
Vitrea Oils	B	-	-	-	-	-	-	-	-
Vodka	A	B	-	-	-	-	-	-	-
Water Acid - mine water	A	A	A	A	C	D	B	D	-
Water in Oil Emulsions	A	-	-	-	-	-	-	-	-
Water - distilled	A	A	A	A	C	D	B	D	A
Water - fresh	A	A	A	A	C	D	B	D	-
Water - salt	A	A	A	A	C	D	B	D	-
Whiskey	A	B	-	-	-	-	-	-	D
White Gasoline	A	A	A	A	A	B	A	B	-
White Liquor (paper)	A	A	-	-	-	-	-	-	-
Wines	A	B	-	-	-	-	-	-	D
Wood Oil	A	-	-	-	-	-	-	-	A
Xenon	-	-	-	-	-	-	-	-	-
Xylene	D	D	A	A	B	C	B	C	A
Xylol	D	D	A	A	B	C	B	C	A
Yeast	A	B	-	-	-	-	-	-	-
Yogurt	A	B	-	-	-	-	-	-	-
Zeric	B	-	-	-	-	-	-	-	-
Zinc Acetate	A	-	-	-	-	-	-	-	-
Zinc Chloride Solutions	A	-	-	-	-	-	-	-	A
Zinc Chromate	A	A	A	A	A	A	A	A	-
Zinc Cyanide	A	A	A	A	A	A	A	A	-
Zinc Hydrate	A	-	-	-	-	-	-	-	-
Zinc Nitrate	A	A	A	A	A	-	A	A	-
Zinc Sulfate	A	A	A	A	A	A	A	A	-

Rating Codes: **A** = Excellent, **B** = Good, **C** = Fair Conditional, **D** = Unsatisfactory, (-) = No Data Available

Coupling Material Chemical Resistance

Material (All ratings are based on 70°F)	Aluminum	Brass	Carbon Steel	304SS	316SS	Nylon	Poly-Propylene
Absorption Oil	-	A	-	-	-	-	-
Acetal	-	A	-	-	-	-	-
Acetaldehyde	A	A	A	A	A	-	A
Acetamide	A	D	-	B	-	-	-
Acetate Solvents (Crude)	A	D	B	A	A	Y	D
Acetate Solvents (Pure)	A	A	D	A	A	Y	D
Acetic Acid (80%)	C	D	D	A	A	D	D
Acetic Acid (50%)	B	D	D	B	A	D	D
Acetic Acid (20%)	B	D	D	B	A	D	D
Acetic Acid (10%)	B	D	D	A	A	D	D
Acetic Anhydride	B	D	B	B	B	D	D
Acetic Ether	A	A	A	A	A	-	B
Acetic Oxide	B	D	D	B	B	-	D
Acetone	A	B	B	A	A	Y	D
Acetophenone	-	-	-	-	-	-	B
Acetylene	A	D	B	A	A	D	D
Acetyl Oxide	B	D	D	B	B	-	D
Acetylene Dichloride	-	-	-	-	-	-	D
Aeroshell 7A, 17 Grease	A	-	A	A	A	-	-
Air 212°F	A	A	A	A	A	-	-
Air, Ambient	A	A	A	A	A	-	A
Aircraft Hydraulic Oil AA	A	A	A	A	A	-	-
Alachlor (Lasso)	-	-	-	A	A	-	-
Alcohol - Amyl	B	B	B	B	B	A	D
Alcohol - Benzyl	B	B	B	A	A	Y	D
Alcohol - Butyl	A	B	B	A	A	D	D
Alcohol - Diacetone	A	A	B	B	B	D	D
Alcohol - Ethyl	A	B	B	B	B	D	D
Alcohol - Hexyl	E	E	E	E	E	D	D
Alcohol - Isobutyl	E	E	E	E	E	D	D
Alcohol - Isopropyl	B	B	B	B	B	D	D
Alcohol - Methyl	B	B	B	B	B	D	D
Alcohol - Octyl	E	E	E	E	E	Y	D
Alcohol - Propyl	B	B	B	A	A	D	D
Alkaryl Sulfonate	-	-	A	A	-	-	-
Allomalaic Acid Solution	-	-	A	A	-	-	-
Allyl Chloride	-	-	A	A	-	-	-
Aluminum Acetate	-	D	-	A	A	-	-
Aluminum Bromide	-	D	D	B	B	-	-
Aluminum Chloride	D	D	D	D	D	Y	Y
Aluminum Fluoride	B	E	D	D	B	D	Y
Aluminum Nitrate	C	D	D	B	B	Y	Y
Aluminum Potassium Sulfate	B	B	D	D	B	D	Y
Aluminum Salts	B	-	-	B	B	-	A
Aluminum Sulfate	D	D	D	E	B	Y	Y
Amines (Mixed)	D	D	-	A	-	-	-
Aminoethanol	-	A	A	A	A	-	-
Ammonia Anhydrous	A	D	A	B	A	Y	D
Ammonia Gas	D	D	A	A	A	Y	D
Ammonia Nitrate	E	E	E	E	E	D	E
Ammonium Acetate	-	D	-	A	A	-	A
Ammonium Bifluoride	E	D	D	E	E	D	Y
Ammonium Carbonate	B	D	B	B	B	Y	Y

Material (All ratings are based on 70°F)	Aluminum	Brass	Carbon Steel	304SS	316SS	Nylon	Poly-Propylene
Ammonium Casenate	E	E	E	E	E	Y	E
Ammonium Chloride	D	D	D	D	D	Y	Y
Ammonium Hydroxide	B	D	A	B	B	Y	Y
Ammonium Metaphosphate	D	-	A	A	A	-	A
Ammonium Nitrate	B	D	D	E	E	Y	Y
Ammonium Nitrite	-	-	-	A	A	-	A
Ammonium Persulfate	-	D	-	A	A	-	D
Ammonium Phosphate	D	D	D	A	B	Y	Y
Ammonium Sulfate	D	D	D	D	B	Y	Y
Ammonium Sulfide	D	D	A	A	A	-	A
Ammonium Thiocyanate	-	-	A	A	A	-	A
Amyl Acetate	D	A	D	A	A	-	D
Amyl Alcohol	A	A	A	A	-	-	-
Amyl Chloride	-	-	-	A	A	-	D
Amy Chloronaphthalene	-	-	-	A	A	-	-
Amyl Napthalene	-	-	-	A	A	-	-
Amyl Phenol	-	-	-	A	A	-	-
Anethole	B	D	B	A	A	-	A
Aniline	E	D	D	A	A	D	D
Aniline Hydrochloride	-	D	-	D	D	-	B
Aniline Oil	B	D	B	A	A	-	A
Animal Fat (Lard)	A	D	A	A	A	-	-
Animal Gelatin	-	-	-	A	A	-	-
Animal Oils	A	-	A	A	A	-	-
Ant Oil	A	A	B	A	A	-	B
Antifreeze	A	A	A	A	A	-	A
Aqua Ammonia	-	D	B	A	A	-	A
Aqua Regia	-	-	-	D	D	-	D
Aromatic Hydrocarbons	B	B	A	A	A	-	-
Arsenic Acid	B	-	B	-	A	-	B
Askarel (Transformer Oil)	-	A	A	A	A	-	B
Asphalt	E	E	B	E	B	D	D
Asphalt (Cut Back)	-	A	A	A	A	-	-
ASTM Oil No. 1	A	A	A	A	A	-	B
ASTM Oil No. 2	A	A	A	A	A	-	D
ASTM Oil No. 3	A	A	A	A	A	-	D
ASTM Reference Fuel A	A	A	A	A	A	-	D
ASTM Reference Fuel B	A	A	A	A	A	-	D
ASTM Reference Fuel C	A	A	A	A	A	-	D
Baltic Types (100, 150, 200, 300, 500)	-	-	-	-	-	-	B
Banvel	-	-	-	-	A	-	-
Barcol B	-	-	A	A	A	-	-
Barite	-	B	A	A	A	-	-
Barium Carbonate	D	B	B	B	B	Y	Y
Barium Chloride	E	B	E	D	E	Y	Y
Barium Hydroxide	D	B	B	B	B	Y	Y
Barium Sulfate	B	B	D	B	B	Y	Y
Barium Sulfide	D	D	B	B	B	Y	Y
Beer	A	B	B	A	A	Y	Y
Beet Sugar Liquors	D	-	D	D	D	-	D
Bellows 80-20 Hydraulic Oil	-	-	-	-	-	-	D
Benzaldehyde	B	B	D	B	B	D	D
Benzene, Benzol	A	B	B	B	B	Y	D

Rating Codes: **A** = Excellent, **B** = Good, **C** = Fair Conditional, **D** = Unsatisfactory, **E** = Contact Thorburn, **Y** = Acceptable, (-) = No Data Available

Coupling Material Chemical Resistance

Material (All ratings are based on 70°F)	Aluminum	Brass	Carbon Steel	304SS	316SS	Nylon	Poly-Propylene
Benzenesulfonic Acid	D	-	D	-	B	-	A
Benzene	A	B	B	B	B	Y	D
Benzoic Acid	B	B	D	B	B	D	D
Benzoic Aldehyde	-	-	A	-	A	-	A
Benzol	A	A	A	A	A	-	D
Benzyl Alcohol (Photo Inhibited)	-	-	A	A	A	-	A
Benzyl Benzoate	-	-	A	A	A	-	-
Bismuth Carbonate	-	-	A	A	A	-	A
Bitumastic	-	A	A	A	A	-	-
Black Liquor	-	-	A	A	A	-	A
Black Sulfate	-	-	A	A	A	-	A
Blast Furnace Gas	-	A	A	A	A	-	-
Bleach (12.5% Active Chlorine)	D	E	D	E	D	D	Y
Borax	D	B	B	A	A	D	Y
Bordeaux Mixture	-	-	-	A	A	-	-
Boric Acid	A	D	D	E	E	X	Y
Brake Fluid (Petroleum Based)	-	A	A	A	A	-	D
Brake Fluid (Synthetic Based)	-	A	A	A	A	-	-
Brine Acid	A	D	D	E	E	D	Y
Bromic Acid	D	D	E	E	E	D	Y
Bromine	-	A	A	A	A	-	D
Bromine Liquid	B	E	E	D	D	D	D
Bromochloromethane	-	A	A	A	A	-	D
Bunker Oil	A	A	A	A	A	-	-
Butadiene, Butylene	B	B	B	B	B	D	D
Butanal	-	A	-	-	-	-	-
Butane	B	B	A	B	B	D	D
Butter Oil (Use FDA Hose)	A	A	A	A	A	-	-
Butyl Acetate	A	B	B	B	B	Y	D
Butyl Alcohol	A	A	A	A	A	-	A
Butyl Carbitol	A	A	A	A	A	-	-
Butyl Ether	A	A	A	A	A	-	-
Butyl Mercaptan	-	-	-	A	A	-	-
Butyl Stearate	A	A	A	A	A	-	-
Butylamine	A	A	A	A	A	-	D
Butyric Acid	B	B	D	B	B	Y	Y
Cake Alum	D	D	D	D	B	-	A
Calcine Liquor	B	-	A	A	A	-	-
Calcium Acetate	A	A	A	A	A	-	-
Calcium Bisulfate	D	E	D	D	B	D	Y
Calcium Bisulfide	E	E	E	E	B	Y	Y
Calcium Bisulfite	D	D	D	E	B	D	Y
Calcium Bromide	D	B	D	D	D	D	D
Calcium Carbonate	D	B	B	A	B	Y	Y
Calcium Chlorate	-	-	-	B	A	-	A
Calcium Chloride	E	B	B	E	E	Y	Y
Calcium Hydrogen Sulfite	-	-	-	A	A	-	A
Calcium Hydrosulfide	-	D	-	B	A	-	A
Calcium Hydroxide	D	B	B	B	B	Y	Y
Calcium Hypochlorite	D	D	D	D	B	D	Y
Calcium Metasilicate	A	A	A	A	A	-	A
Calcium Nitrate Solutions	A	A	A	A	A	-	A
Calcium Oxide	-	-	-	-	B	-	-

Material (All ratings are based on 70°F)	Aluminum	Brass	Carbon Steel	304SS	316SS	Nylon	Poly-Propylene
Calcium Silicate	A	A	A	A	A	-	-
Calcium Sulfate	-	A	A	A	A	-	A
Calcium Sulfide	B	-	A	A	A	-	-
Caliche Liquors	B	-	A	A	A	-	-
Cane Sugar Liquors	A	B	A	A	A	-	A
Carbolic Acid	B	D	D	A	A	-	-
Carbolic Acid (Phenol)	B	D	D	A	A	-	-
Carbolic Acid (Phenol, 82-95% in Creosols)	B	D	D	A	A	-	-
Carbon Bisulfide	A	D	B	B	B	Y	D
Carbon Dioxide - Dry	A	A	B	B	B	Y	Y
Carbon Dioxide - Wet	A	D	C	B	B	D	Y
Carbon Disulfide	A	D	B	B	B	Y	D
Carbon Monoxide	A	A	B	A	A	Y	Y
Carbon Tetrachloride	D	E	B	A	E	Y	D
Carbonic Acid	A	B	B	B	B	D	Y
Castor Oil	B	B	B	B	B	D	Y
Caustic Potash	D	E	D	E	B	Y	Y
Caustic Soda (see Sodium Hydroxide)	D	B	B	E	E	D	Y
Cellosolves	B	B	B	B	B	D	Y
Cellosolve Acetate	-	-	A	A	A	-	A
Cellosolve Butyl	-	-	A	A	A	-	A
China Wood Oil	A	A	A	A	A	-	-
Chlorine - Liquid	E	E	B	E	C	D	D
Chlorine - Water	-	-	-	D	D	-	A
Chloroacetic Acid Solution	-	B	D	D	D	-	A
Chlorobenzene	A	A	A	A	A	-	D
Chlorobromomethane	-	A	A	A	A	-	D
Chloroform	E	E	D	E	E	D	D
Chloropentane	-	-	-	A	A	-	D
Chloropropylene Oxide	-	-	A	-	-	-	A
Chlorosulfonic Acid	E	D	B	D	D	D	D
Chlorothene	-	A	-	A	A	-	-
Chlorotoluene	A	A	A	A	A	-	-
Clorox (5.5% bleach)	D	E	D	E	B	D	E
Chromic Acid (50%)	B	D	D	C	E	D	D
Chromium Trioxide	D	D	D	D	B	-	A
Citric Acid	C	D	D	C	E	D	D
Coal Tar	A	A	A	A	A	-	-
Cobalt Nickel Plating Solution	-	-	-	-	B	-	-
Cocoa Butter	-	-	A	A	A	-	-
Cod Liver Oil	A	A	A	A	A	-	-
Coke Oven Gas	B	C	B	B	B	D	D
Copper Arsenate	-	-	A	A	A	-	-
Copper Chloride	D	D	D	D	D	Y	Y
Copper Cyanide	D	D	E	B	B	D	E
Copper Nitrate	-	D	D	A	A	-	A
Copper Sulfate	D	D	D	E	B	Y	Y
Corn Oil	A	A	A	A	A	-	D
Corn Syrup	A	-	A	A	A	-	-
Cottonseed Oil	A	A	A	A	A	-	A
Creosote	A	D	B	A	A	-	B
Cresol	A	-	B	A	A	-	B
Crotonic Acid	-	-	A	D	-	-	-

Rating Codes: **A** = Excellent, **B** = Good, **C** = Fair Conditional, **D** = Unsatisfactory, **E** = Contact Thorburn, **Y** = Acceptable, (-) = No Data Available

Coupling Material Chemical Resistance

Material (All ratings are based on 70°F)	Aluminum	Brass	Carbon Steel	304SS	316SS	Nylon	Poly-Propylene
Crude Oil	A	A	A	A	A	-	A
Crude Wax	-	A	A	A	A	-	A
Cryolite	-	A	A	A	A	-	D
Crylic Acid	B	B	B	B	B	D	D
Cupric Arsenate	-	-	A	A	A	-	-
Cupric Nitrate	-	D	D	A	A	-	A
Cutting Oil (Mineral Oil Base)	-	A	A	A	A	-	D
Cutting Oil, Sulfur Base	-	A	A	A	A	-	A
Cutting Oil, Water Soluble	-	A	A	A	A	-	A
Cyanide, Copper	-	D	-	A	A	-	A
Cyanide, Mercuric	D	-	-	-	-	-	A
Cyanide, Silver	D	D	B	A	A	-	A
Cyanide, Sodium	D	D	B	A	A	-	-
Cyclohexane	B	B	B	B	B	Y	D
Cyclohexanol	-	-	-	-	-	-	A
Cyclohexanone	B	-	-	A	A	-	D
Cymene	A	A	A	A	A	-	-
Decalin	-	A	-	-	-	-	A
Deicing Fluid	A	A	B	A	A	-	A
Denatured Alcohol	A	A	A	A	A	-	-
Detergents	B	B	B	A	B	Y	Y
Developing Solutions	-	-	-	A	A	-	-
Dextrin	-	-	-	A	A	-	-
Dextrose	B	E	E	E	E	Y	Y
Dextrose							
Diacetone	-	A	A	A	A	-	A
Diacetone Alcohol	A	A	A	A	A	-	A
Diammonium Phosphate	D	-	D	B	A	-	A
Diazinon	-	-	-	-	-	-	B
Dibenzyl Ether	A	A	A	A	A	-	-
Dibutyl Phthalate	A	A	A	A	A	-	B
Dibutylsebacate	-	A	-	-	-	-	-
Dichlorobenzene (ortho)	-	A	-	A	A	-	-
Dichlorobenzene (para)	-	A	-	A	A	-	-
Dichloroethylene	-	-	-	-	-	-	D
Dichloromethane	-	A	A	A	A	-	-
Diesel Fuels	A	A	B	A	A	Y	D
Diethanolamine	A	D	A	A	A	-	-
Diethanolamine (20%)	A	D	A	A	A	-	-
Diethyl Ether	A	A	B	A	A	-	A
Diethyl Phthalate	-	A	-	A	A	-	-
Diethyl Sebacate	-	A	-	A	A	-	-
Diethylamine	B	E	D	B	B	D	Y
Diethylene Dioxide	A	A	A	A	A	-	A
Diethylene ether	A	A	A	A	A	-	A
Diethylene Glyco	A	A	A	A	A	-	A
Dihydroxyethyl Ether	A	A	A	A	A	-	A
Diisobutyl Ketone	-	A	A	A	A	-	A
Diisobutylene	-	A	-	A	A	-	-
Diisopropyl Ketone	-	A	-	A	A	-	-
Diisopropylidene Acetone	-	A	A	A	A	-	-
Dimethyl Aniline	-	A	-	-	-	-	-
Dimethyl Ether	A	A	A	A	A	-	-

Material (All ratings are based on 70°F)	Aluminum	Brass	Carbon Steel	304SS	316SS	Nylon	Poly-Propylene
Dimethyl Formamide	-	-	A	A	A	-	A
Dimethyl Phthalate	-	A	-	-	-	-	-
Dimethylcarbinol	A	B	A	A	A	-	A
Dimethylformamide	-	-	A	A	A	-	A
Dimethylketone	A	A	A	A	A	-	B
Diocetyl Phthalate	A	A	A	A	A	-	D
Dioxane	A	A	A	A	A	-	A
Dioxolane	A	A	A	A	A	-	-
Dipentene	A	A	A	A	A	-	-
Dirco Oils	A	A	A	A	A	-	-
Disodium Phosphate	E	E	A	E	A	Y	Y
DMF (Dimethylformamide)	-	-	A	A	A	-	A
Dowtherm A	A	A	A	A	A	-	-
Dowtherm SR-1	A	A	B	A	A	-	A
Duro Oils	A	A	A	A	A	-	-
Ethylene Chloride	E	E	B	E	E	Y	D
Ethylene Dichloride	E	B	B	B	B	Y	D
Ethylene Glycol	A	B	B	B	B	Y	D
Ethylene Oxide	A	D	B	B	B	D	D
Enamels	-	A	-	-	-	-	-
Epichlorohydrin	-	-	A	-	-	-	A
Essential Oils	A	A	A	A	A	-	-
Ethano	A	B	A	A	A	-	A
Ethanolamine	-	A	A	A	A	-	-
Ethers	B	B	B	A	A	Y	D
Ethers	A	A	A	A	A	-	B
Ethyl Acetate	E	E	B	B	B	Y	D
Ethyl Acetoacetate	A	A	A	A	A	-	D
Ethyl Alcohol	A	B	A	A	A	-	A
Ethyl Bromide	-	A	-	A	A	-	-
Ethyl Butyrate	A	-	-	A	A	-	-
Ethyl Chloride	E	E	B	E	A	Y	D
Ethyl Ether	A	A	B	A	A	-	A
Ethyl Mercaptan	-	-	B	-	-	-	-
Ethyl Pentachlorobenzene	-	A	B	A	A	-	-
Ethyl Phthalate	-	A	-	A	A	-	-
Ethyl Silicate	A	A	A	A	A	-	-
Ethylamine	-	A	-	A	A	-	-
Ethylbenzene	-	A	A	A	A	-	-
Ethylcellulose	-	A	A	A	A	-	-
Fatty Acids	A	C	D	E	A	Y	Y
Ferric Chloride	D	D	D	D	D	D	Y
Ferric Hydroxide	E	E	E	A	A	Y	E
Ferric Nitrate (10 - 50%)	D	D	D	B	B	D	Y
Ferric Sulfate	D	D	D	E	E	D	Y
Ferrous Chloride	D	D	E	D	D	D	Y
Ferrous Nitrate	-	-	-	A	A	-	A
Ferrous Sulfate	B	B	D	B	E	D	Y
Fertilizer	A	A	A	A	A	-	A
Fire-Resistant Hydra-Fluid	A	A	A	A	A	-	-
Fixing Solution (Photo)	-	-	-	A	A	-	A
Fluoboric Acid	D	E	A	E	E	D	Y
Fluosilicic Acid	A	-	-	-	-	-	A

Rating Codes: **A** = Excellent, **B** = Good, **C** = Fair Conditional, **D** = Unsatisfactory, **E** = Contact Thorburn, **Y** = Acceptable, (-) = No Data Available

Coupling Material Chemical Resistance

Material (All ratings are based on 70°F)	Aluminum	Brass	Carbon Steel	304SS	316SS	Nylon	Poly-Propylene
E Formaldehyde (50%)	E	B	D	A	A	D	Y
Formic Acid (Anhydrous)	A	D	D	E	E	D	Y
Freon 11	B	B	D	B	B	D	D
Freon 12	B	B	D	B	B	D	D
Freon 22	B	B	D	B	B	D	D
Fruit Juices	B	B	D	B	B	Y	Y
Fuel Oil	B	B	B	B	B	Y	D
Fumaric Acid	-	-	-	A	A	-	-
Furan	A	A	A	A	A	-	-
Furfural	B	B	B	B	B	Y	D
Furfuran	A	A	A	A	A	-	-
Fusel Oil	A	A	A	A	A	-	-
Fyrguard 150, 200	A	A	A	A	A	-	-
Fyrquel (15R&O, 220R&O, 550R&O)	A	-	A	-	-	-	-
Fyrquel (90, 150, 220, 300, 550, 1000)	A	-	A	-	-	-	-
Gallic Acid	-	-	D	A	A	-	A
Gasohol	A	A	B	A	A	-	D
Gasoline - Refined	B	B	B	B	B	Y	D
Gasoline - Sour	D	B	B	B	B	Y	D
Gasoline (Oxygenated- Blended with MTBE)	A	A	B	A	A	-	D
Gelatin	B	B	D	B	B	Y	Y
Glucose	A	A	A	A	A	-	-
Glue	B	B	B	E	B	E	Y
Glycerine	A	A	B	A	A	Y	Y
Glycerol	A	A	B	A	A	-	-
Glycols	B	B	B	B	B	Y	Y
Grease	A	A	A	A	A	-	-
Grease, Silicone Base	A	A	A	A	A	-	-
Green Liquor	E	E	B	E	E	E	Y
Green Sulfate Liquor	-	-	A	A	A	-	-
Heptane	B	B	B	B	B	Y	D
Hexaldehyde	E	E	E	E	E	-	-
Hexane	B	B	B	A	A	Y	D
Hexanol	A	B	A	A	A	-	-
Hexene	-	A	A	A	A	-	-
Hexyl Alcohol	A	B	A	A	A	-	-
Hexylene	-	A	A	A	A	-	-
Houghto-Safe (1055, 1110, 1115, 1120, 1130)	A	A	A	A	A	-	-
Houghto-Safe (271, 416, 520, & 616, 620)	A	A	A	A	A	-	-
Houghto-Safe (5048)	A	A	A	A	A	-	-
Houghto-Safe (625, 640 & 525 under 100°F)	A	A	A	A	A	-	-
HPO (Sodium Thiosulfate)	B	D	D	A	A	-	-
Hy-Chock Oil	-	-	A	A	A	-	-
Hydrafluid 760	A	A	A	A	A	-	-
Hydrafluid (AZR&O, A, B, AA, C)	A	-	A	A	A	-	-
Hydrasol A	A	-	A	A	A	-	-
Hydraulic Fluid (Phosphate Ester Base)	-	-	A	A	A	-	-
Hydraulic Fluid (Polyalphaolefin)	A	A	A	A	A	-	-
Hydraulic Fluid (Std. Petroleum Oils)	A	A	A	A	A	-	-
Hydraulic Fluid (Water Glycol Based)	A	A	A	A	A	-	-
Hydraulic Fluid (HF-18, HF-20)	A	A	A	A	A	-	-
Hydraulic Fluid (HF-31)	A	A	A	A	A	-	-
Hydrobromic Acid (20%)	D	D	D	D	D	D	Y

Material (All ratings are based on 70°F)	Aluminum	Brass	Carbon Steel	304SS	316SS	Nylon	Poly-Propylene
Hydrobromic Acid (50%)	D	D	D	D	D	D	Y
Hydrochloric Acid (20%)	D	D	D	D	D	D	Y
Hydrochloric Acid (38%)	D	D	D	D	D	D	Y
Hydrocyanic Acid	B	D	B	B	B	D	Y
Hydrofluosilicic Acid (10 -50%)	D	B	D	D	B	D	E
Hydrogen Chloride (Dry Gas)	D	B	B	E	E	D	Y
Hydrogen Fluoride	-	-	A	A	A	-	-
Hydrogen Gas	A	A	E	A	A	D	Y
Hydrogen Peroxide (50%)	E	D	D	E	E	D	Y
Hydrogen Peroxide (35% or less)	A	D	D	B	A	-	-
Hydrogen Peroxide (50% or less)	A	D	D	B	A	-	-
Hydrogen Peroxide (70% or less)	A	D	D	B	A	-	-
Hydrogen Peroxide (90% or less)	A	D	D	B	A	-	-
Hydrogen Sulfide	E	E	E	D	B	D	Y
Hydroquinine	-	-	-	A	A	-	-
Hydroquinine Solution	-	-	-	A	A	-	-
Hypo Chlorous Acid	D	D	D	D	D	D	D
Ink (Printers)	-	B	B	B	A	-	-
Ink Oil	-	A	A	A	A	-	-
Insulating Oil	-	A	A	A	A	-	-
Iodine	A	D	D	D	D	D	Y
Iron Acetate Liquor	-	-	A	A	A	-	A
Iron Sulfate Solution	D	D	D	A	A	-	A
Isobutanol	A	B	A	A	A	-	-
Isobutyl Alcohol	A	B	A	A	A	-	-
Isocyanate	-	-	A	A	A	-	-
Isooctane	B	A	A	A	A	-	-
Isopropanol	A	B	A	A	A	-	A
Isopropyl Acetate	A	A	A	A	A	-	-
Isopropyl Alcohol	A	B	A	A	A	-	A
Isopropyl Ether	E	B	E	A	B	Y	D
Isopropyltoluene	A	A	A	A	A	-	-
Jet Fuel (JP4, JP5)	B	A	B	B	B	D	D
Karo Syrup	-	-	-	A	A	-	-
Kerosene	B	B	B	B	B	D	D
Ketchup	-	-	-	A	A	-	-
Ketones	B	B	B	B	B	Y	D
Lacquer (Alcohol or Acetate as Solvent)	A	A	D	D	A	-	-
Lacquer (Toluene or Xylene as Solvent)	A	A	D	D	A	-	-
Lactic Acid (25%)	C	B	D	E	E	Y	Y
Lactic Acid (80%)	B	B	D	E	E	Y	Y
Lactol	-	A	A	A	A	-	-
Lard Oil	B	E	C	B	B	Y	Y
Lasso	-	-	-	A	A	-	-
Latex Paint	A	A	A	A	A	-	-
Lead Acetate	D	D	D	B	B	D	Y
Lead Chloride	D	E	E	B	B	D	E
Lead Nitrate Solution	-	-	A	A	A	-	-
Lead Sulfate	D	E	D	B	B	D	E
Lecithin	-	-	-	A	A	-	-
Ligroin	-	-	B	A	A	-	-
Lime	-	-	-	-	B	-	-
Lime (Chlorinated - normal 35-37% Chlorine)	-	-	-	-	B	-	-

Rating Codes: **A** = Excellent, **B** = Good, **C** = Fair Conditional, **D** = Unsatisfactory, **E** = Contact Thorburn, **Y** = Acceptable, (-) = No Data Available

Coupling Material Chemical Resistance

Material (All ratings are based on 70°F)	Aluminum	Brass	Carbon Steel	304SS	316SS	Nylon	Poly-Propylene
Lime Sulfur Solution	D	D	B	A	A	-	-
Lime Sulphur	D	D	D	B	B	D	Y
Lime (Chlorinated)	-	-	D	B	A	-	-
Limonene	A	A	A	A	A	-	-
Lindane	-	-	-	A	A	-	-
Linseed Oil	B	B	B	B	B	Y	Y
Liquid Soap	A	A	A	A	A	-	-
Lonoleic Acid	B	D	D	B	B	D	Y
Lubricants (oil)	B	A	B	B	B	Y	D
Machine Oil (Under 135°F)	A	A	A	A	A	-	-
Magnesium Chloride	D	D	E	E	E	D	Y
Magnesium Hydroxide	B	B	B	A	A	D	Y
Magnesium Nitrate	B	B	B	B	B	D	Y
Magnesium Oxide	E	E	E	E	E	D	E
Magnesium Sulfate	B	E	E	B	B	D	Y
Magnesium Carbonate	B	E	E	B	B	D	Y
Malathion	-	A	A	A	A	-	-
Maleic Acid	E	B	D	E	B	D	Y
Maxmul	-	-	A	-	A	-	-
MBK (Methyl Butyl Ketone)	A	A	A	A	A	-	-
Mecurious Nitrate Solution	D	-	A	A	A	-	-
MEK (Ethyl Methyl Ketone)	A	A	A	A	A	-	-
Mercuric Chloride	D	D	D	D	E	D	Y
Mercuric Cyanide	D	D	D	B	B	D	Y
Mercury	D	D	B	A	A	Y	Y
Mesityl Oxide	A	A	A	A	A	-	-
Metallic Soaps	A	A	A	A	A	-	-
Methane	A	A	B	A	A	Y	D
Methanol	B	B	B	B	B	Y	Y
Methoxychlor Solution	-	-	A	A	A	-	-
Methylamine	-	-	A	A	A	-	-
Methyl Acetate	A	A	A	A	A	-	-
Methyl Acrylate	A	A	A	A	A	-	-
Methyl Alcohol	A	A	A	A	A	-	-
Methyl Bromide	D	E	B	B	B	D	D
Methyl Butyl Ketone	A	A	A	A	A	-	-
Methyl Cyanide	-	-	A	A	A	-	-
Methyl Ethyl Ketone	B	B	B	B	B	Y	D
Methyl Formate	A	A	A	A	A	-	-
Methyl Isobutyl Ketone	B	B	B	B	B	Y	D
Methyl Methacrylate	B	E	D	B	B	D	Y
Methyl Nutanathiol	-	-	-	A	A	-	-
Methyl Phenol	A	-	B	A	A	-	B
Methyl Salicylate	A	A	A	A	A	-	-
Methylene Chloride	E	B	B	E	E	Y	D
Methylene Dichloride	D	A	A	A	A	-	-
Milk	A	D	C	A	A	Y	Y
Mineral oil	B	A	B	A	B	Y	Y
Mobile Therm 603	A	A	A	A	A	-	-
Molasses	B	D	B	A	A	-	-
Monochloroacetic Acid Solution	-	B	D	D	D	-	-
Monochlorobenzene	-	A	A	A	A	-	-
Monoethanolamine	-	A	A	A	A	-	-

Material (All ratings are based on 70°F)	Aluminum	Brass	Carbon Steel	304SS	316SS	Nylon	Poly-Propylene
Monomethylamine	-	-	A	A	A	-	-
Monosodium Phosphate	D	D	A	A	A	-	-
Motor Oil	A	A	A	A	A	-	-
Mould Oil	-	-	A	A	A	-	-
Mouth Wash	A	A	A	A	A	-	-
Muriatic Acid	D	E	E	D	D	D	Y
Mustard	-	-	D	A	A	-	-
Naptha	-	A	B	A	A	-	-
Naphthalene	B	B	B	A	A	Y	Y
Naphthalene	B	B	B	B	B	Y	D
Neutral Oil	-	A	A	A	A	-	-
Nickel Acetate	A	A	A	A	A	-	-
Nickel Chloride	D	D	D	E	E	D	Y
Nickel Nitrate	D	-	-	-	B	-	-
Nickel Plating Solution	-	-	-	A	A	-	-
Nickel Sulfate	D	D	E	B	B	D	Y
Nicotine Salts	-	-	A	D	B	-	-
Niter Cake	D	D	D	A	A	-	-
Nitogen, Liquid	A	A	A	A	A	-	-
Nitric Acid (100%)	A	D	D	B	E	D	D
Nitric Acid (30%)	D	D	D	A	E	D	D
Nitric Acid (50%)	D	D	D	B	E	D	D
Nitrobenzene	A	B	B	B	B	Y	Y
Nitroethane	-	A	-	A	A	-	-
Nitrogen Gas	A	A	A	A	A	-	-
Nitrogen Oxide	-	D	A	A	A	-	-
Nitromethane	-	A	-	A	A	-	-
Nitropropane	-	A	-	A	A	-	-
Nitrosyl Chloride	-	-	-	A	A	-	-
Nitrous Acid (Up to 10%)	D	D	D	A	A	-	-
Nitrous Oxide	-	D	A	A	A	-	-
Octadecanoic Acid	D	D	D	B	A	-	-
Octanol	A	B	A	A	A	-	-
Octyl Alcohol	A	B	A	A	A	-	-
Oil - Castor	B	B	B	B	B	Y	Y
Oil - Coconut	B	E	C	B	B	Y	Y
Oil - Corn	B	B	B	E	B	Y	Y
Oil - Cotton Seed	B	B	B	B	B	Y	Y
Oil - Fuel	B	B	B	B	B	Y	D
Oil - Linseed	B	B	B	B	B	Y	Y
Oil - Mineral	B	A	B	A	B	Y	Y
Oil - Silicon	B	A	B	B	B	Y	Y
Oil - Vegetable	B	B	B	A	A	Y	D
Oils, Animal	A	A	A	A	A	-	-
Oleic Acid	B	C	B	E	A	Y	D
Oleum	B	D	B	B	B	D	D
Olive Oil	A	B	B	A	A	-	A
Ortho-Dichlorobenzene	-	A	-	A	A	-	-
Oxalic Acid	B	E	D	D	D	D	Y
Oxygen	B	B	B	B	B	D	D
Ozone	A	A	A	A	A	-	A
Paint (inorganic)	A	A	-	A	A	-	-
Palm Oil	A	A	A	A	A	-	-

Rating Codes: **A** = Excellent, **B** = Good, **C** = Fair Conditional, **D** = Unsatisfactory, **E** = Contact Thorburn, **Y** = Acceptable, (-) = No Data Available

Coupling Material Chemical Resistance

Material (All ratings are based on 70°F)	Aluminum	Brass	Carbon Steel	304SS	316SS	Nylon	Poly-Propylene
Palmitic Acid	B	C	C	B	B	D	Y
Paraffin	B	B	B	B	B	Y	Y
Paraformaldehyde	A	-	-	A	A	-	-
Peanut Oil	A	A	A	A	A	-	A
Pentanol	A	A	A	A	A	-	-
Perchloric Acid	-	-	C	B	A	-	A
Perchloroethylene	B	B	B	E	E	D	D
Petrolatum	B	E	C	B	B	Y	E
Petroleum Ether	-	A	B	A	A	-	-
Phenol (Carbonic Acid)	A	A	C	E	A	D	D
Phenyl Chloride	A	A	A	A	A	-	D
Phorone	-	A	A	A	A	-	-
Phosphoric Acid (25-50%)	D	D	D	E	E	D	Y
Phosphoric Acid (50-85%)	D	D	D	E	E	D	Y
Photographic Solutions	E	E	D	A	A	D	D
Phthalic Anhydride	E	B	B	A	A	D	D
Picric Acid	A	D	D	B	B	D	E
Plating Solutions - Brass	E	E	E	E	B	D	Y
Plating Solutions - Cadmium	E	B	E	E	B	D	Y
Plating Solutions - Chrome (40%)	D	E	D	B	B	D	Y
Plating Solutions - Copper Cyanide	E	E	E	E	E	D	Y
Plating Solutions - Gold	E	E	E	E	A	D	Y
Plating Solutions - Iron	E	E	E	E	E	D	Y
Plating Solutions - Lead	E	E	E	A	A	D	Y
Plating Solutions - Nickel	E	E	E	A	A	D	Y
Plating Solutions - Silver	E	E	E	A	A	D	Y
Plating Solutions - Tin	E	E	E	E	C	D	Y
Plating Solutions - Zinc	E	E	E	E	E	D	Y
Potash	-	D	B	A	A	-	A
Potassium Acetate	D	D	B	E	E	Y	Y
Potassium Bicarbonate (30%)	D	B	B	A	A	Y	Y
Potassium Carbonate (50%)	D	B	B	A	A	Y	Y
Potassium Chlorate (30%)	B	D	B	B	A	D	Y
Potassium Chloride (30%)	D	D	B	E	E	Y	Y
Potassium Chromate (30%)	B	B	E	B	B	D	Y
Potassium Cyanide (30%)	D	D	B	B	B	D	Y
Potassium Dichromate (30%)	A	B	B	A	A	D	Y
Potassium Hydroxide (90%)	D	D	E	D	E	D	Y
Potassium Nitrate (80%)	A	B	B	B	B	D	Y
Potassium Permanganate (20%)	B	B	B	B	B	D	Y
Potassium Sulfate (10%)	A	B	B	A	A	Y	Y
Propane	A	A	B	B	B	D	D
Propionic Acid	-	-	A	A	-	-	-
Propylene Glycol	B	B	B	B	B	Y	Y
Propylene Oxide (90%)	E	E	E	A	A	D	D
Purina insecticide	A	B	A	A	A	-	-
Puropale RX Oils	A	A	A	A	A	-	-
Pydraul (10E, 29E-LT, 30E, 60, 65E, 115SE)	A	A	A	A	A	-	-
Pyrene	D	B	D	B	B	Y	D
Pyridine	B	B	B	B	B	-	D
Pyrogalllic Acid	B	B	B	B	B	D	D
Pyroguard (160, 230, 630)	-	-	A	A	A	-	-
Pyroguard (51, 53, 55)	-	-	A	A	A	-	-

Material (All ratings are based on 70°F)	Aluminum	Brass	Carbon Steel	304SS	316SS	Nylon	Poly-Propylene
Pyroguard C, D	A	A	A	A	A	-	-
Quenching Oil	A	-	-	A	A	-	-
Quintolubric 822	A	A	A	A	A	-	-
Ramrod (Ag Spray)	A	A	A	A	A	-	-
Rando Oils	A	A	A	A	A	-	-
Rapeseed Oil	A	A	A	A	A	-	-
Red Oil (MIL-5606)	A	B	B	B	A	-	A
Refined Wax (Petroleum)	-	A	A	A	A	-	-
Regal Oils R&O	A	A	A	A	A	-	-
Salicylic Acid	B	-	-	A	A	-	-
Salt Water	-	B	B	A	A	-	-
Sewage	B	A	D	A	A	-	-
Silicone Greases	-	A	A	A	A	-	-
Silicone Oils	-	A	A	A	A	-	-
Silver Nitrate	D	D	D	B	A	D	Y
Skydrol (500A & 7000)	A	-	A	A	A	-	-
Soap Solutions	B	B	B	B	B	Y	Y
Soda Ash	D	B	A	A	A	-	A
Sodium Acetate	A	B	D	B	B	Y	Y
Sodium Bicarbonate (20%)	B	B	C	A	A	Y	Y
Sodium Bisulfate	D	E	B	E	E	Y	Y
Sodium Bisulfite	D	B	D	E	E	Y	Y
Sodium Borate	B	B	C	B	B	Y	Y
Sodium Carbonate	D	B	B	E	B	Y	Y
Sodium Chlorate (50%)	B	B	D	B	B	D	Y
Sodium Chloride	D	D	B	B	A	-	-
Sodium Chromate	D	D	B	A	A	-	-
Sodium Cyanide	D	D	B	E	E	Y	Y
Sodium Dichromate	B	D	B	B	B	D	Y
Sodium Fluoride (70%)	-	-	-	-	B	-	-
Sodium Hydrochloride (30%)	D	B	B	E	E	D	Y
Sodium Hydroxide (30%)	D	B	B	A	A	D	Y
Sodium Hydroxide (50%)	D	D	C	A	E	D	Y
Sodium Hydroxide (70%)	D	D	C	B	B	D	Y
Sodium Hydroxide (40%)	D	D	B	A	A	-	-
Sodium Hypochlorite	D	D	D	E	E	D	Y
Sodium Metaphosphate	D	D	D	B	B	D	D
Sodium Nitrate (40%)	A	B	B	A	A	Y	Y
Sodium Perborate (10%)	B	D	B	B	B	D	Y
Sodium Perborate (10%)	B	D	B	B	B	D	Y
Sodium Peroxide (10%)	B	D	B	B	B	D	Y
Sodium Phosphate	D	D	-	A	A	-	-
Sodium Silicate	A	B	B	B	B	Y	Y
Sodium Sulfate	E	B	B	E	A	Y	Y
Sodium Sulfide (50%)	D	D	B	E	B	D	Y
Sodium Thiosulphate	B	D	D	B	B	Y	Y
Solnus Oils	A	A	A	A	A	-	-
Soybean Oil	-	-	A	A	A	-	-
Spent Acid	-	-	-	A	A	-	-
Stannic Chloride	D	D	D	D	D	D	Y
Stannous Chloride	D	D	D	D	E	D	D
Starch Gum	-	-	-	A	A	-	A
Stauffer Jet 1	A	A	A	A	A	-	-

Rating Codes: **A** = Excellent, **B** = Good, **C** = Fair Conditional, **D** = Unsatisfactory, **E** = Contact Thorburn, **Y** = Acceptable, (-) = No Data Available

Coupling Material Chemical Resistance

Material (All ratings are based on 70°F)	Aluminum	Brass	Carbon Steel	304SS	316SS	Nylon	Poly-Propylene
Stauffer Jet 2	A	A	A	A	A	-	-
Steam	E	E	E	E	E	D	E
Stearic Acid	B	C	C	B	A	Y	Y
Stoddard's Solvent	B	B	B	B	B	D	Y
STPP (Sodium Tripolyphosphate)	D	D	-	A	A	-	-
Styrene	D	B	B	D	B	-	-
Sucrose Solutions	-	-	A	A	A	-	-
Sugar Liquors (Beet)	A	B	B	A	A	Y	Y
Sugar Liquors (Cane)	A	B	B	B	B	Y	Y
Sulfate Liquors	B	D	C	E	B	D	Y
Sulfite Liquors	D	D	D	B	B	D	D
Sulfur Chloride	D	E	D	E	E	D	D
Sulfur Dioxide (Dry)	B	B	A	E	B	D	Y
Sulfur Trioxide	B	B	B	E	B	D	D
Sulfuric Acid (100%)	D	D	B	E	E	D	D
Sulfuric Acid (to 10%)	D	B	D	D	D	D	Y
Sulfurous Acid	B	B	D	D	E	D	Y
Sun R&O Oils	A	-	A	A	A	-	-
Suntac HP Oils	A	-	A	A	A	-	-
Suntac WR Oils	A	-	A	-	A	-	-
Sunvis Oils (700, 800, 900)	-	-	A	A	A	-	-
Synthetic Oil (Citgo)	-	-	A	A	A	-	-
Syrup	-	-	A	A	A	-	-
Tall Oil	-	-	-	D	B	-	-
Tall Oil (Under 150°F)	-	-	-	D	B	-	-
Tallow	A	B	B	B	B	-	-
Tannic Acid	D	E	D	B	B	D	Y
Tanning Liquors	A	E	E	A	A	D	Y
Tar (Under 100°F)	A	B	A	A	A	-	-
Tartaric Acid	E	E	E	A	A	Y	Y
Tellus Oils	A	A	A	A	A	-	-
Tenol Oils	-	-	A	A	A	-	-
Tergitol	-	B	B	A	A	-	-
Tetrahydrofuran	D	C	A	-	B	Y	D
Tetrahydrofuran (THF)	-	-	B	-	-	-	D
Theobromo Oil	-	-	A	A	A	-	-
Titanium Tetrachloride	D	D	B	E	B	D	D
Toluene	A	A	A	A	A	Y	D
Toluene Diisocyanate	-	-	A	A	A	-	-
Tomato Juice	B	E	C	B	B	D	Y
Transformer Oil (Askarel Types)	-	A	A	A	A	-	B
Transformer Oil (Petroleum Types)	A	A	A	A	A	-	-
Transmission Fluid	-	A	A	A	A	-	-
Tributoxyethyl Phosphate	D	-	A	-	-	-	-
Tributyl Phosphate	D	-	A	-	-	-	-
Trichloroethylene	A	E	B	E	E	Y	D
Trichloroethylene	D	A	D	-	A	-	-
Tricresyl Phosphate	D	-	A	-	B	-	-
Triethanolamine	B	D	B	B	B	Y	D
Triethylamine	E	E	E	B	B	Y	D
Trihydroxybenzoic Acid	-	-	D	A	A	-	A
Trinitriphenol	D	D	D	A	A	-	-
Trisodium Phosphate	D	B	B	A	A	Y	Y

Material (All ratings are based on 70°F)	Aluminum	Brass	Carbon Steel	304SS	316SS	Nylon	Poly-Propylene
Tung Oil	A	A	A	A	A	-	-
Turpentine	B	D	B	A	A	D	D
Ucon (Hydrolube Types 150CP, 200CP)	A	A	A	A	A	-	-
Ucon (M1)	A	A	A	A	A	-	-
Union Hydraulic Tractor Fluid	A	A	A	A	A	-	-
Urea (50%)	B	E	B	B	B	Y	Y
Urine	E	E	B	A	A	D	Y
Varnish	-	B	B	A	A	-	-
Vegetable Oils	A	-	A	A	A	-	-
Versilube (F-50, F-44)	A	A	A	A	A	-	-
Vinegar	B	D	B	B	B	D	Y
Vinyl Acetate	A	B	-	A	B	-	-
Vinyl Chloride	A	D	B	A	A	-	-
Vitrea Oils	-	-	A	A	A	-	-
VM&P Naptha	B	A	A	A	A	-	-
Water (Distilled)	D	B	D	B	B	Y	Y
Water (Sea)	B	B	D	B	B	Y	Y
Water Acid (Mine)	D	D	D	E	E	D	Y
Whiskey	D	B	B	A	A	D	Y
White Liquor	B	E	D	B	B	D	Y
Wine	D	B	D	A	A	D	Y
Xylene	B	B	B	B	B	Y	D
Zeric	-	-	-	A	A	-	-
Zinc Chloride	D	D	D	D	B	Y	Y
Zinc Nitrate	E	E	E	B	B	D	Y
Zinc Sulfate (50%)	D	B	D	A	A	D	Y

Rating Codes: **A** = Excellent, **B** = Good, **C** = Fair Conditional, **D** = Unsatisfactory, **E** = Contact Thorburn, **Y** = Acceptable, (-) = No Data Available

Temperature Conversion Chart

Celsius	Fahrenheit
-400	-688
-300	-508
-250	-418
-200	-328
-150	-238
-100	-148
-95	-139
-90	-130
-85	-121
-80	-112
-75	-103
-70	-94
-65	-85
-60	-76
-55	-67
-50	-58
-49	-56
-48	-54
-47	-53
-46	-51
-45	-49
-44	-47
-43	-45
-42	-43
-41	-42
-40	-40
-39	-38
-38	-36
-37	-35
-36	-33
-35	-31
-34	-29
-33	-27
-32	-26
-31	-24
-30	-22
-29	-20
-28	-18
-27	-17
-26	-15
-25	-13
-24	-11
-23	-9

Celsius	Fahrenheit
-22	-8
-21	-6
-20	-4
-19	-2
-18	-0.4
-17	1
-16	3
-15	5
-14	7
-13	9
-12	10
-11	12
-10	14
-9	16
-8	18
-7	19
-6	21
-5	23
-4	25
-3	27
-2	28
-1	30
0	32
1	34
2	36
3	37
4	39
5	41
6	43
7	45
8	46
9	48
10	50
11	52
12	54
13	55
14	57
15	59
16	61
17	63
18	64
19	66
20	68

Celsius	Fahrenheit
21	70
22	72
23	73
24	75
25	77
26	79
27	81
28	82
29	84
30	86
31	88
32	90
33	91
34	93
35	95
36	97
37	99
38	100
39	102
40	104
41	106
42	108
43	109
44	111
45	113
46	115
47	117
48	118
49	120
50	122
75	167
100	212
150	302
200	392
250	482
300	572
400	752
500	932
600	1112
700	1292
800	1472
900	1652
1000	1832

Celsius to Fahrenheit ($^{\circ}\text{C} \times (9/5) + 32 = ^{\circ}\text{F}$) | Fahrenheit to Celsius: $((^{\circ}\text{F} - 32) \times (5/9)) = ^{\circ}\text{C}$

Pressure Conversion Chart

psi	in/H2O	in/Hg	mm/H2O	mm/Hg	kg/cm2	bar	mbar	Pa	mPa	kPa
1.0	27.71	2.036	703.1	51.75	0.0703	0.0689	68.95	6895	0.006895	6.895
1.2	33.22	2.443	843.7	62.06	0.0844	0.0827	82.74	8274	0.008274	8.274
1.4	38.75	2.850	684.3	72.40	0.0984	0.0965	96.52	9652	0.009652	9.652
1.6	44.29	3.258	1125	82.74	0.1125	0.1103	110.0	11030	0.01103	11.03
1.8	49.82	3.665	1266	93.09	0.1266	0.1241	124.1	12410	0.01241	12.41
2.0	55.36	4.072	1406	103.4	0.1406	0.1379	137.9	13790	0.01379	13.79
2.2	60.90	4.479	1547	113.8	0.1547	0.1517	151.7	15170	0.01517	15.17
2.4	66.43	4.886	1687	124.1	0.1687	0.1655	165.5	16550	0.01655	16.55
2.6	71.97	5.294	1828	134.5	0.1828	0.1793	179.3	17930	0.01793	17.93
2.8	77.51	5.701	1969	144.8	0.1968	0.1930	193.0	19300	0.01930	19.30
3.0	83.04	6.108	2109	155.1	0.2109	0.2068	203.8	20680	0.02068	20.68
3.2	88.58	6.515	2250	165.5	0.2250	0.2206	220.6	22060	0.02206	22.06
3.4	94.11	6.922	2390	175.8	0.2390	0.2344	234.4	23440	0.02344	23.44
3.6	99.65	7.330	2531	186.2	0.2531	0.2482	248.2	24820	0.02482	24.82
3.8	105.2	7.737	2672	196.5	0.2672	0.2620	262.0	26200	0.02620	26.20
4.0	110.7	8.144	2812	206.9	0.2812	0.2758	275.8	27580	0.02758	27.58
4.2	116.3	8.551	2953	217.2	0.2953	0.2896	289.6	28960	0.02896	28.96
4.4	121.8	8.958	3094	227.5	0.3094	0.3034	303.4	30338	0.03034	30.34
4.6	127.3	9.366	3234	237.9	0.3234	0.3172	317.2	31720	0.03172	31.72
4.8	132.9	9.773	3375	248.2	0.3375	0.3310	331.0	33100	0.03310	33.10
5.0	138.4	10.18	3515	258.6	0.3515	0.3447	344.7	34470	0.03447	34.47
5.2	143.9	10.59	3656	268.9	0.3656	0.3585	358.5	35850	0.03585	35.85
5.4	149.5	10.99	3797	279.3	0.3797	0.3723	372.3	37230	0.03723	37.23
5.6	155.0	11.40	3937	289.6	0.3937	0.3861	386.1	38610	0.03861	38.61
5.8	160.5	11.81	4078	299.9	0.4078	0.3999	399.9	39990	0.03999	39.99
6.0	166.1	12.22	4218	310.3	0.4218	0.4137	413.7	41370	0.04137	41.37
6.2	171.6	12.62	4359	320.6	0.4359	0.4275	427.5	42750	0.04275	42.75
6.4	177.2	13.03	4500	331.0	0.4500	0.4413	441.3	44130	0.04413	44.13
6.6	182.7	13.44	4640	341.3	0.4640	0.4550	455.0	45500	0.04550	45.50
6.8	188.2	13.84	4781	351.7	0.4781	0.4688	468.8	46880	0.04688	46.88
7.0	193.8	14.25	4922	362.0	0.4921	0.4826	482.6	48260	0.04826	48.26
7.2	199.3	14.66	5062	372.3	0.5062	0.4964	496.4	49640	0.04964	49.64
7.4	204.8	15.07	5203	382.7	0.5203	0.5102	510.2	51020	0.05102	51.02
7.6	210.4	15.47	5343	393.0	0.5343	0.5240	524.0	52400	0.05240	52.40
7.8	215.9	15.88	5484	403.4	0.5484	0.5378	537.8	53780	0.05378	53.78
8.0	221.4	16.29	5625	413.7	0.5625	0.5516	551.6	55160	0.05516	55.16
8.2	227.0	16.70	5765	424.1	0.5765	0.5654	565.4	56540	0.05654	56.54
8.4	232.5	17.10	5906	434.4	0.5906	0.5792	579.2	57920	0.05792	57.92
8.6	238.0	17.51	6047	444.7	0.6046	0.5929	592.9	59290	0.05929	59.29
8.8	243.6	17.92	6187	455.1	0.6187	0.6067	606.7	60670	0.06067	60.67
9.0	249.1	18.32	6328	465.4	0.6328	0.6205	620.5	62050	0.06205	62.05
10.0	276.8	20.36	7031	517.1	0.7031	0.6895	689.5	68950	0.06895	68.95
11.0	304.5	22.40	7734	568.9	0.7734	0.7584	758.4	75840	0.07584	75.84
12.0	332.2	24.43	8437	620.6	0.8437	0.8274	827.4	82740	0.08274	82.74
13.0	359.8	26.47	9140	672.3	0.9140	0.8963	896.3	89630	0.08963	89.63
14.0	387.5	28.50	9843	724.0	0.9843	0.9652	965.2	96520	0.09652	96.52
15.0	415.2	30.54	10550	775.7	1.0550	1.0340	1034.0	103400	0.10340	103.40
16.0	442.9	32.58	11250	827.4	1.1250	1.1030	1103.0	110300	0.11030	110.30
17.0	470.6	34.61	11950	879.1	1.1950	1.1720	1172.0	117200	0.11720	117.20
18.0	498.2	36.65	12660	930.6	1.2650	1.2410	1241.0	124100	0.12410	124.10
19.0	525.9	36.68	13360	982.6	1.3360	1.3100	1310.0	131000	0.13100	131.00
20.0	553.6	40.72	14060	1034.0	1.4060	1.3790	1379.0	137900	0.13790	137.90
21.0	581.3	42.76	14770	1086.0	1.4760	1.4480	1448.0	144800	0.14480	144.80
22.0	609.0	44.79	15470	1138.0	1.5470	1.5170	1517.0	151700	0.15170	151.70
23.0	636.7	46.83	16170	1189.0	1.6170	1.5860	1586.0	158600	0.15860	158.60
24.0	664.3	48.86	16870	1241.0	1.6870	1.6550	1655.0	165500	0.16550	165.50
25.0	692.0	50.90	17580	1293.0	1.7580	1.7240	1724.0	172400	0.17240	172.40

Pressure Conversion Calculations

From	To	Multiply By	Example
atm (Atmosphere)	bar	1.01325	1.1 atm x 1.01325 = 1.115 bar
	MPa	0.10132	1.1 atm x 0.10132 = 0.111 MPa
	PSI	14.696	1.1 atm x 14.696 = 16.166 PSI
bar	atm	0.98692	10 bar x 0.98692 = 9.8692 atm
	MPa	0.1	10 bar x 0.1 = 1.0 MPa
	PSI	14.504	10 bar x 14.504 = 145 PSI
MPa (Megapascal)	atm	9.8692	10 MPa x 9.8692 = 98.692 atm
	bar	10	10 MPa x 10 = 100 bar
	PSI	145.0	10 MPa x 145.0 = 1450 PSI
PSI (Pounds / Square Inch)	atm	0.068	100 PSI x 0.068 = 6.80 atm
	bar	0.0689	100 PSI x 0.0689 = 6.89 bar
	MPa	0.00689	100 PSI x 0.00689 = 0.689 MPa

Flow Conversion Calculations

From	To	Multiply By	Example
CFM (Cubic Feet / Minute)	l/min	28.32	100 CFM x 28.32 = 2832 l/min
	l/s	0.472	100 CFM x 0.472 = 47.2 l/s
	m ³ /h	1.699	100 CFM x 1.699 = 169.9 m ³ /h
l/min (Liter / Minute)	CFM	0.0353	100 l/min x 0.0353 = 3.5 CFM
	l/s	0.0167	100 l/min x 0.0167 = 1.7 l/s
	m ³ /h	0.06	100 l/min x 0.06 = 6 m ³ /h
l/s (Liter / Second)	CFM	2.119	10 l/s x 2.119 = 21.2 CFM
	l/min	60	10 l/s x 60 = 600 l/min
	m ³ /h	3.6	10 l/s x 3.6 = 36 m ³ /h
m³/h (Cubic Meter / Hour)	CFM	0.5885	10 m ³ /h x 0.5885 = 5.885 CFM
	l/min	16.667	10 m ³ /h x 16.667 = 166.7 l/min
	l/s	0.2777	10 m ³ /h x 0.2777 = 2.777 l/s
GPM us (Gallon / Minute)	l/min	3.7854	10 GPM us x 3.7854 = 37.85 l/min
GPM uk (Gallon / Minute)	l/min	4.5461	10 GPM uk x 4.5461 = 45.46 l/min

Force Conversion Calculations

From	To	Multiply By	Example
lbf (Pound Force)	kp	0.454	10 lbf x 0.454 = 4.54 kp
	N	4.448	10 lbf x 4.448 = 44.48 N
kp (Kilogram Force)	lbf	2.205	10kp x 2.205 = 22.05 lbf
	N	9.806	10 kp x 9.806 = 98.06 N
N (Newton)	lbf	0.2248	10 N x 0.2248 = 2.25 lbf
	kp	0.1020	10 n x 0.1020 = 1.02 kp

Volume Conversion Calculations

From	To	Multiply By	Example
ft³ (Cubic Foot)	gl UK	6.228	10 ft ³ x 6.228 = 62.28 gl UK
	gl US	7.48	10 ft ³ x 7.48 = 74.8 gl US
	l	28.32	10 ft ³ x 28.32 = 283.2 l
	m ³	0.0283	10 ft ³ x 0.0283 = 0.283 m ³
gl UK (Gallon UK)	ft ³	0.1605	10 gl UK x 0.1605 = 1.605 ft ³
	gl US	1.2009	10 gl UK x 1.2009 = 12.009 gl US
	l	4.546	10 gl UK x 4.546 = 45.46 l
	m ³	0.0045	10 gl UK x 0.0045 = 0.045 m ³
gl US (Gallon US)	ft ³	0.1336	10 gl US x 0.1336 = 1.336 ft ³
	gl UK	0.8326	10 gl US x 0.8326 = 8.326 gl UK
	l	3.785	10 gl US x 3.785 = 37.85 l
	m ³	0.0037	10 gl US x 0.0037 = 0.037 m ³
l (Liter)	ft ³	0.0353	100 l x 0.0353 = 3.53 ft ³
	gl UK	0.220	100 l x 0.220 = 22.0 gl UK
	gl US	0.264	100 l x 0.264 = 26.4 gl US
	m ³	0.001	100 l x 0.001 = 0.1 m ³
m³ (Cubic meter)	ft ³	35.3	10 m ³ x 35.3 = 353 ft ³
	gl UK	219.96	10 m ³ x 219.96 = 2199.6 gl UK
	gl US	264.17	10 m ³ x 264.17 = 2641 gl US
	l	1000	10 m ³ x 1000 = 10,000 l

Mass Conversion Calculations

From	To	Multiply By	Example
g (Gram)	kg	0.001	10 g x 0.001 = 0.01 kg
	lb	0.0022	10 g x 0.0022 = 0.022 lb
	oz	0.0352	10 g x 0.0352 = 0.352 oz
kg (Kilogram)	g	1000	10 kg x 1000 = 10,000 g
	lb	2.205	10 kg x 2.205 = 22.05 lb
	oz	35.273	10 kg x 35.273 = 352.73 oz
lb (Pound)	g	453.9	10 lb x 453.9 = 4535 g
	kg	0.4539	10 lb x 0.4539 = 4.535 kg
	oz	16	10 lb x 16 = 160 oz
oz (Ounce)	g	28.349	10 oz x 28.349 = 283.49 g
	kg	0.0283	10 oz x 0.0283 = 0.283 kg
	lb	0.0625	10 oz x 0.0625 = 0.625 lb

Length Conversion Calculations

From	To	Multiply By	Example
ft (Foot)	in	12	10 ft x 12
	m	0.3048	10 ft x 0.3048
	mm	304.8	10 ft x 304.8
in (Inch)	ft	0.0833	10 in x 0.0833
	m	0.0254	10 in x 0.0254
	mm	25.4	10 in x 25.4
m (Meter)	ft	3.28083	10 m x 3.28083
	in	39.3699	10 m x 39.3699
	mm	1000	10 m x 1000
mm (Millimeter)	ft	0.00328	10 mm x 0.00328
	in	0.0393	10 mm x 0.0393
	m	0.001	10 mm x 0.001

Weight Per Length Conversion Calculations

From	To	Multiply By	Example
lb/ft (Pounds per foot)	kg/m	1.48816	10 lb/ft x 1.48816 = 14.8816 kg/m
kg/m (Kilograms per meter)	lb/ft	0.67197	10 kg/m x 0.67197 = 6.7197 lb/ft

Temperature Conversion Calculations

From	To	Conversion	Example
°C (Celsius)	°F	$^{\circ}\text{F} = (^{\circ}\text{C} \times (9/5)) + 32$	$(10^{\circ}\text{C} \times (9/5)) + 32 = 50^{\circ}\text{F}$
	K	$\text{K} = ^{\circ}\text{C} + 273.15$	$10^{\circ}\text{C} + 273.15 = 283.15 \text{ K}$
	°R	$^{\circ}\text{R} = (^{\circ}\text{C} \times (9/5)) + 491.67$	$(10^{\circ}\text{C} \times (9/5)) + 491.67 = 509.67^{\circ}\text{R}$
°F (Fahrenheit)	°C	$^{\circ}\text{C} = (^{\circ}\text{F} - 32) \times (5/9)$	$(10^{\circ}\text{F} - 32) \times (5/9) = -12.22^{\circ}\text{C}$
	K	$\text{K} = (^{\circ}\text{F} + 459.67) \times (5/9)$	$(10^{\circ}\text{F} + 459.67) \times (5/9) = 260.93 \text{ K}$
	°R	$^{\circ}\text{R} = ^{\circ}\text{F} + 459.67$	$10^{\circ}\text{F} + 459.67 = 469.67^{\circ}\text{R}$
°K (Kelvin)	°C	$^{\circ}\text{C} = \text{K} - 273.15$	$10\text{K} - 273.15 = -263.15^{\circ}\text{C}$
	°F	$^{\circ}\text{F} = (\text{K} \times (9/5)) - 459.67$	$(10\text{K} \times (9/5)) - 459.67 = -441.67^{\circ}\text{F}$
	°R	$^{\circ}\text{R} = \text{K} \times (9/5)$	$10\text{K} \times (9/5) = 18^{\circ}\text{R}$
°R (Rankine)	°C	$^{\circ}\text{C} = (^{\circ}\text{R} - 491.67) \times (5/9)$	$(10^{\circ}\text{R} - 491.67) \times (5/9) = -267.59^{\circ}\text{C}$
	°F	$^{\circ}\text{F} = ^{\circ}\text{R} - 459.67$	$10^{\circ}\text{R} - 459.67 = -449.67^{\circ}\text{F}$
	K	$\text{K} = ^{\circ}\text{R} \times (5/9)$	$10^{\circ}\text{R} \times (5/9) = 5.6 \text{ K}$

Velocity of Fluid Flow Through Hose

V	GPM	d	Calculation
Velocity	Gallons per Minute	Inside Diameter of Hose	$V = 0.408 \times \text{GPM} / d^2$

Flow of Water Through 100 ft Length Hose

Straight Smooth Bore (US Gallons per Minute)

PSI @ Hose Inlet	Hose ID											
	1/2	5/8	3/4	1	1 1/4	1 1/2	2	2 1/2	3	4	6	8
20	4	8	12	26	47	76	161	290	468	997	2895	6169
30	5	9	15	32	58	94	200	360	582	1240	3603	7679
40	6	11	18	38	68	110	234	421	680	1449	4209	8970
50	7	12	20	43	77	124	264	475	767	1635	4748	10118
60	8	14	22	47	85	137	291	524	846	1804	5239	11165
75	9	15	25	53	95	154	329	591	955	2035	5910	12595
100	10	18	29	62	112	180	384	690	1115	2377	6904	14712
125	11	20	33	70	126	203	433	779	1258	2681	7788	15595
150	12	22	36	77	139	224	478	859	1388	2958	8593	18313
200	15	26	42	90	162	262	558	1004	1621	3455	10038	21390



Air Hose Friction Loss

Approximate pressure loss expressed in pounds per square inch (psi) through 100 foot hose assembly lengths (with coupling installed).

Hose ID	Pressure (PSI)	Cubic Feet of Air Per Minute (SCFM)											
		40	50	60	70	80	90	100	110	120	130	140	150
1/2	50	20.2	36.2										
	60	16.8	29.6	46.8									
	70	14.0	24.8	40.0	56.8								
	80	12.0	21.6	34.8	50.4	69.2							
	90	10.8	19.0	29.6	44.0	61.0	82.0						
	100	9.6	16.8	26.6	38.6	54.4	73.3						
	110	8.6	15.2	24.0	35.2	49.2	66.6	89.0					
3/4	50	3.0	4.8	7.0	8.8	13.0	17.0	22.8	28.4				
	60	2.4	3.8	5.5	4.6	10.4	13.6	17.2	22.4	28.2			
	70	1.8	3.0	4.6	6.4	8.4	11.0	14.0	17.6	22.0			
	80	1.6	2.6	3.8	5.5	7.2	9.4	11.6	14.4	17.6	21.2		
	90	1.4	2.2	3.2	4.5	6.2	8.0	10.0	12.4	15.0	18.0	21.6	
	100	1.2	2.0	2.8	4.0	5.4	7.0	8.8	10.8	13.2	15.8	18.8	22.2
	110	1.0	1.8	2.6	3.6	4.8	6.2	7.8	9.8	11.8	14.2	16.8	19.8
1	50	0.6	1.0	1.6	2.2	3.0	4.0	5.2	7.0	9.6	14.0		
	60	0.6	0.8	1.2	1.6	2.4	3.0	4.0	5.2	6.6	8.2	11.0	14.4
	70	0.4	0.8	1.0	1.4	2.0	2.6	3.2	4.0	5.0	6.2	7.6	9.4
	80	0.4	0.6	1.0	1.4	1.6	2.2	2.8	3.4	4.0	4.8	5.4	7.0
	90	0.4	0.6	0.8	1.2	1.4	1.8	2.4	2.8	3.4	4.0	4.8	5.6
	100	0.4	0.4	0.8	1.0	1.2	1.6	2.0	2.4	3.0	3.5	4.2	4.8
	110	0.4	0.4	0.6	0.8	1.2	1.4	1.8	2.2	2.6	3.0	3.6	4.2
1 1/4	50		0.4	0.4	0.6	0.8	1.0	1.4	2.0				
	60		0.2	0.4	0.6	0.6	1.0	1.2	1.5	2.0	2.4	3.0	
	70			0.4	0.4	0.6	0.8	0.8	1.2	1.4	1.6	2.0	2.6
	80			0.2	0.4	0.4	0.6	0.8	1.0	1.2	1.4	1.6	2.0
	90				0.4	0.4	0.6	0.6	0.8	1.0	1.2	1.4	1.6
	100				0.2	0.4	0.4	0.6	0.8	0.8	1.0	1.2	1.4
	110				0.2	0.4	0.4	0.6	0.6	0.8	1.0	1.0	1.2
1 1/2	50					0.4	0.4	0.4	0.6	0.8	0.8	1.0	1.2
	60					0.2	0.4	0.4	0.4	0.6	0.6	0.8	1.0
	70						0.2	0.4	0.4	0.6	0.6	0.6	0.8
	80							0.2	0.4	0.4	0.4	0.6	0.8
	90								0.2	0.4	0.4	0.4	0.6
	100									0.4	0.4	0.4	0.4
	110									0.4	0.4	0.4	0.4

Pressure loss in PSI

Water Hose Friction Loss

Approximate pressure loss expressed in pounds per square inch (psi) through 100 foot Lengths of straight, smooth bore hose.

Water Flow USGPM	Hose ID														
	1/2	5/8	3/4	1	1 1/4	1 1/2	2	2 1/2	3	4	5	6	8	10	12
1	1.41														
2	5.09	1.72	0.71												
5	27.7	9.36	3.85	0.95	0.32	0.13									
10	100	33.7	13.9	3.42	1.15	0.47	0.12								
15		71.4	29.4	7.24	2.44	1.00	0.25	0.08							
20		122	50.0	12.3	4.16	1.71	0.42	0.14							
25			75.6	18.6	6.28	2.59	0.64	0.21							
30			106	26.1	8.80	3.62	0.89	0.30	0.12						
35			141	34.7	11.7	4.82	1.19	0.40	0.16						
40				44.4	15.0	6.17	1.52	0.51	0.21						
45				55.3	18.6	7.67	1.89	0.64	0.26						
50				67.1	22.7	9.32	2.30	0.77	0.32						
60				94.1	31.7	13.1	3.22	1.09	0.45						
70				125	42.2	17.4	4.28	1.44	0.59						
80					54.0	22.2	5.48	1.85	0.76						
90					67.2	27.7	6.81	2.30	0.95	0.23					
100					81.7	33.6	8.28	2.79	1.15	0.28					
125					123	50.38	12.5	4.22	1.74	0.43					
150						71.1	17.5	5.91	2.43	0.60	0.20				
175						94.6	23.3	7.86	3.24	0.80	0.27				
200						121	29.8	10.1	4.14	1.02	0.34				
225							37.1	12.5	5.15	1.27	0.43				
250							45.1	15.2	6.26	1.54	0.52				
275							53.8	18.1	7.47	1.84	0.62				
300							63.2	21.3	8.77	2.16	0.73	0.30			
350							84.0	28.3	11.7	2.87	0.97	0.40			
400							108	36.3	14.9	3.68	1.24	0.51			
450								45.1	18.6	4.57	1.54	0.64			
500								54.8	22.6	5.56	1.88	0.77	0.19		
600								76.8	31.6	7.79	2.63	1.08	0.27		
700								102	42.1	10.4	3.49	1.44	0.35	0.12	
800								131	53.8	13.3	4.47	1.84	0.45	0.15	
1000									81.4	20.0	6.76	2.78	0.69	0.23	0.10
1200									114	28.1	9.47	3.90	0.96	0.32	0.13
1400									152	37.3	12.6	5.18	1.28	0.43	0.18
1600										47.8	16.1	6.64	1.64	0.55	0.23
1800										59.5	20.0	8.25	2.03	0.69	0.28
2000										72.2	24.4	10.0	2.47	0.83	0.34
2500											36.8	15.2	3.73	1.26	0.52
3000											51.6	21.2	5.23	1.76	0.73



Recommended Air Flow

The table below lists the recommended air flow in standard cubic feet per minute (SCFM) as a guide in sizing hose in compressed air systems.

System Pressure (PSI)	Nominal Hose ID										
	1/8	1/4	3/8	1/2	3/4	1	1 1/4	1 1/2	2	2 1/2	3
5	0.5	1.2	2.7	4.9	6.6	13	27	40	80	135	240
10	0.8	1.7	3.9	7.7	11	21	44	64	125	200	370
20	1.3	3.0	6.6	13	18	35	75	110	215	350	600
40	2.5	5.5	12	23	34	62	135	200	385	640	1100
60	3.5	8.0	18	34	50	93	195	290	560	900	1600
80	4.7	10	23	44	65	120	255	380	720	1200	2100
100	5.8	13	29	54	80	150	315	470	900	1450	2600
150	8.6	20	41	80	115	220	460	680	1350	2200	3900
200	11	26	58	108	155	290	620	910	1750	2800	5000
250	14	33	73	135	200	370	770	1150	2200	3500	6100

Recommended Water Flow

The table below lists the maximum recommended flow rates based on a maximum acceptable pressure drop of 15% per 100 feet of straight, smooth bore hose. Where pressure drop must be reduced, hose size (I.D.) must be increased. Flow rates based on 100 U.S. gallons per minute.

Pressure at Hose Inlet (PSI)	Nominal Hose ID											
	1/2	5/8	3/4	1	1 1/4	1 1/2	2	2 1/2	3	4	6	8
20	4	8	12	26	47	76	161	290	468	997	2895	6169
30	5	9	15	32	58	94	200	360	582	1240	3603	7679
40	6	11	18	38	68	110	234	421	680	1449	4209	8970
50	7	12	20	43	77	124	264	475	767	1635	4748	10118
60	8	14	22	47	85	137	291	524	846	1804	5239	11165
75	9	15	25	53	95	154	329	591	955	2035	5910	12595
100	10	18	29	62	112	180	384	690	1115	2377	6904	14712
125	11	20	33	70	126	203	433	779	1258	2681	7788	16595
150	12	22	36	77	139	224	478	859	1388	2958	8593	18313
200	15	26	42	90	162	262	558	1004	1621	3455	10038	21390

Weight Of Water In One Foot of Hose

The figures in the table below is useful when considering support requirements for hose assemblies during operation. As an example, a 10 inch I.D., 30 ft length of hose can contain 1021 lbs of water when filled.

Hose ID	lb	kg
1/4	0.021	0.010
3/8	0.048	0.022
1/2	0.085	0.039
5/8	0.133	0.060
3/4	0.191	0.087
1	0.340	0.154
1 1/4	0.532	0.241
1 1/2	0.766	0.347
2	1.361	0.618

Hose ID	lb	kg
2 1/2	2.127	0.965
3	3.063	1.389
4	5.445	2.470
5	8.509	3.859
6	12.252	5.558
8	21.782	9.880
10	34.034	15.438
12	49.009	22.230
14	66.733	30.270

Force Acting On End Fittings

The figures in the table below demonstrate the importance of good fitting selection and installation. As an example, a 4" I.D. water discharge hose rated for 150 psi has 1885 lbs of force acting on the end fitting when operated at full design pressure.

Hose ID	50 psi	100 psi	150 psi	300 psi	500 psi	1000 psi
1/4	2	2	7	15	25	49
3/8	6	11	17	33	55	110
1/2	10	20	29	59	98	196
3/4	22	44	66	133	221	442
1	39	79	118	236	393	785
1 1/4	61	123	184	368	614	1227
1 1/2	88	177	265	530	884	1767
2	157	314	471	942	1571	3142
2 1/2	245	491	726	1473	2454	4909
3	353	707	1060	2121	3534	7070
4	628	1257	1885	3770	6283	12566
5	982	1964	2945	5891	9818	19635
6	1414	2827	4241	8482	14137	28274
8	2513	5027	7540	15080	25133	50274
10	3927	7854	11781	23562	39270	78540
12	5655	11310	16965	33929	56549	113100

Temperature of Saturated Steam

Steam and temperature possess a reliable relationship whereby if the pressure of the steam is known, its temperature can be predicted (and vice versa). Below is a graph and table of this relationship.

Gauge Pressure		Temperature	
psi	bar	°C	°F
25	1.72	130	267
30	2.07	134	274
40	2.76	141	287
50	3.45	148	298
60	4.14	153	307
80	5.52	162	324
100	6.89	170	338
120	8.27	177	350
140	9.65	182	361
160	11.03	188	371
180	12.41	193	379
200	13.79	198	388
225	15.51	203	397
250	17.24	208	406
275	18.96	212	414
300	20.68	216	422
325	22.41	221	429
350	24.13	225	437

Thorburn Hose Size Codes

Code	in	mm	DN	Code	in	mm	DN
02	1/8	3.2	6	36	2 1/4	57.6	-
03	3/16	4.8	-	40	2 1/2	63.5	65
04	1/4	6.4	8	48	3	76.2	80
05	5/16	7.9	-	56	3 1/2	88.9	90
06	3/8	9.5	10	64	4	101.6	100
08	1/2	12.7	15	72	4 1/2	115.2	115
10	5/8	15.9	-	80	5	127.0	125
12	3/4	19.0	20	96	6	152.4	150
14	7/8	22.2	-	112	7	177.8	-
16	1	25.4	25	128	8	203.2	200
20	1 1/4	31.8	32	144	9	228.6	-
24	1 1/2	38.1	40	160	10	254.0	250
32	2	50.8	50	192	12	304.8	300

Canadian Municipal Threads (2 1/2" and 4")

In Canada there are numerous types of threads used in fire protection. Commonly used are:

- 2" and smaller - National Straight Pipe thread (NPS, NPSH, IPS).
- 2-1/2" - Thread type varies by province or municipality.
- 3" and larger - NH (NST) is the most common.

Province	Municipality	Common Thread	OD (Male) ----- Threads Per Inch	Thread Size	
				2 1/2"	4"
British Columbia	Most Areas	BAT (BCT)	ODM*	3.0000	4.6250
			TPI**	8	6
Alberta	Most Areas	BAT (AMA)	ODM*	3.0000	
			TPI**	8	
Saskatchewan	Most Areas	WCT	ODM*	3.2500	
			TPI**	6	
	Climax	BAT	ODM*	3.0000	
			TPI**	8	
	Moose Jaw	MJT	ODM*	3.0620	
			TPI**	7	
	Yorkton		ODM*	3.0400	
			TPI**	7 1/2	
Manitoba	Most Areas	WCT	ODM*	3.2500	
			TPI**	6	
	Some Areas		ODM*		4.8500
			TPI**		6
	Brandon		ODM*	3.000 Sharp	
			TPI**	8	
	Portage La Prairie	CSA	ODM*	3.1250	
			TPI**	5	
Ontario	Most Areas	CSA	ODM*	3.1250	
			TPI**	5	
Quebec	Most Areas	QST	ODM*	3.0310	
			TPI**	7	
	Arvida	WCT	ODM*	3.2500	
			TPI**	6	
	Beauport	QCT	ODM*	3.2500 Sharp	
			TPI**	5	
	Buckingham	WCT	ODM*	3.2500	
			TPI**	6	
	Charlesbourg		ODM*	3.2500	
			TPI**	5	
	Chicoutimi		ODM*	3.0780 NF	
			Female	3.0780 Sharp	
		TPI**	8		

Notes: * ODM = Outside Diameter of Male Adapter. ** TPI = Threads Per Inch

Canadian National Threads

Thread Type	Common Thread Abbr.	OD (Male) ----- Threads Per Inch	Thread Size											
			3/4"	1"	1 1/4"	1 1/2"	2"	2 1/2"	3"	3 1/2"	4"	4 1/2"	5"	6"
National Hose Thread	NST (NH)	ODM*	1.3750	1.3750	1.6718	1.9900	2.5156	3.0686	3.6239	4.2439	5.0109	5.7609	6.2600	7.0250
		TPI**	8	8	8	9	8	7 1/2	6	6	4	4	4	4
National Straight Iron Pipe	IPS (NPS) (NPSH)	ODM*	1.0353	1.2951	1.6399	1.8788	2.3528	2.8410	3.4700	3.9700	4.4700	4.9700	5.5300	6.5900
		TPI**	14	11 1/2	11 1/2	11 1/2	11 1/2	8	8	8	8	8	8	8
National Tapered Iron Pipe	NPT (TIPT)	ODM*	1.0353	1.2951	1.6399	1.8788	2.3528	2.8410	3.4700	3.9700	4.4700	4.9700	5.5300	6.5900
		TPI**	14	11 1/2	11 1/2	11 1/2	11 1/2	8	8	8	8	8	8	8
British Standard Parallel Pipe	BSPP	ODM*	1.0410	1.3090	1.6500	1.8820	2.3470	2.9600	3.400	-	4.4500	-	5.4500	6.4500
		TPI**	14	11	11	11	11	11	11	-	11	-	11	11

Notes: * ODM = Outside Diameter of Male Adapter. ** TPI = Threads Per Inch

U.S.A. Common Threads

Size	NST (NH) Outside Diameter (Male)		Threads Per Inch	NPSH Outside Diameter (Male)		NPT Outside Diameter (Male)		Threads Per Inch
	in	mm		in	mm	in	mm	
3/4	-	-	-	1	1.03	1	0.98	14
1	1 3/8	1.37	8	1 1/4	1.29	1 1/4	1.23	11 1/2
1 1/2	2	1.99	9	1 7/8	1.87	1 7/8	1.87	11 1/2
2	2 1/2	2.51	8	2 3/8	2.35	2 5/16	2.29	11 1/2
2 1/2	3 1/16	3.06	7 1/2	2 13/16	2.84	2 3/4	2.76	8
3	3 5/8	3.62	6	3 1/2	3.47	3 3/8	3.38	8
3 1/2	4 1/2	4.24	6	4	3.97	3 7/8	3.88	8
4	5	5.01	4	4 1/2	4.47	4 3/8	4.38	8
4 1/2	5 3/4	5.76	4	5	4.97	-	-	8
5	6 1/4	6.26	4	5 9/16	5.56	5 7/16	5.44	8
6	7	7.02	4	6 5/8	6.62	6 1/2	6.50	8

Coupling Thread Compatibility

Thread Type	System Name	Compatibility	Sealing Method
BSPP	British Pipe Parallel	Male BSPP - Female BSPP	Washer
		Female BSPP - Male BSPP	Washer
		Female BSPP - Male BSPT	Washer
BSPTTr	British Standard Pipe Taper	Male BSPTTr - Female BSPTTr	Thread
		Male BSPTTr - Female BSPP	Washer
		Female BSPTTr - Male BSPTTr (Not Compatible with Male BSPP)	Thread
CHT	American Standard Fire Hose Thread (1" National Hose Thread is Chemical Hose Thread aka Booster Hose Thread)	1" Male NST (NH) - 1" Female NST (NH)	Washer
		1" Female NST (NH) - 1" Male NST (NH)	Washer
		1" thread used on both 3/4" hose and 1" hose	Not Compatible
GHT	Garden Hose Thread	Male GHT - Female GHT	Washer
		Female GHT - Male GHT	Washer
		Thread is the same for all size hose	Not Compatible
IPS	Iron Pipe Straight Thread	Generic name for Straight Pipe Thread (See NPSH for compatibility)	Washer
IPT	Iron Pipe Thread	Generic name for All Pipe Thread	(4)
JIC	Joint Industrial Committee	Used with other mating JIC threads	Mechanical
NST (NH)	American Standard Fire Hose Coupling Thread (National Hose Thread aka National Standard Thread)	Male NST (NH) - Female NST (NH)	Washer
		Female NST (NH) - Male NST (NH) (1)	
NPT	American Standard Taper Pipe Thread (National Pipe Thread)	Male NPT - Female NPT	Thread
		Male NPT - Female NPTF	Thread
		Male NPT - Female NPSM	Washer
		Male NPT - Female NPSH	Washer
		Female NPT - Male NPT	Thread
		Female NPT - Male NPTF (2)	Thread
NPTF	American Standard Taper Pipe Fuel Dryseal Thread (National Pipe Tapered Dryseal)	Male NPTF - Female NPTF	Thread
		Male NPTF - Female NPT	Thread
		Male NPTF - Female NPSM	Washer
		Male NPTF - Female NPSH	Washer
		Female NPTF - Male NPTF	Thread
		Female NPTF - Male NPT	Thread
		Female NPTF - Male NPSM or NPSH (3)	Not Compatible
NPSH	American Standard Straight Mechanical Joints (National Pipe Straight Mechanical)	Male NPSH - Female NPSH	Washer
		Female NPSH - Male NPSH	Washer
		Female NPSH - Male NPT	Washer
		Female NPSH - Male NPTF	Washer
		Female NPSH - Male NPSM	Washer
NPSM	American Standard Straight Mechanical Joints (National Pipe Straight Mechanical)	Male NPSM - Female NPSM	Mechanical or Washer (Mating fittings must be the same type)
		Male NPSM - Female NPSH	
		Female NPSM - Male NPSM	
		Female NPSM - Male NPT	
		Female NPSM - Male NPTF	
SIPT	Straight Iron Pipe Thread	Generic name for Straight Pipe Thread	Washer
TIPT	Tapered Iron Pipe Thread	Generic name for Tapered Pipe Thread	Thread
NYFD	NYFD Fire Department	Straight Thread - Used in New York City	Washer
Chicago	Chicago Fire Department	Straight Thread - Used in Chicago	Washer

Notes: (1) Thread pitch and diameters of fire threads may vary according to local and municipal regulations. Not compatible with other systems. (2) Not compatible with Male NPSM or Male NPSH. (3) NPTF with NPTF threads do not require sealant for the initial use, but sealant is required afterwards. (4) More Information is required.

Minimum Bend Radius



The Bend Radius is the radius to which the hose can be bent in service without damage or shortening its life. Textile reinforced hoses have a tendency to kink as the bend radius is reduced. A helical wire is used when a hose must withstand severe bends without flattening or kinking. The minimum bend radius of a Thorburn hose is established at 72°F. Temperature changes, either lower or higher, will effect the minimum bend radius. Caution should be taken to assure proper hose selection for the actual application temperature of both the material handled and the ambient temperature surrounding the application. During storage of hose, ambient temperature should also be considered to prevent hose damage. When possible, minimum bending radius of the hose should be as large as possible to avoid damage to the hose and early hose failure.

Bend Radius Calculations

General Formula to Determine the Bend Length:

Angle of bend x $2\pi r$ = minimum length of hose

360° to make bend

$\pi = 3.14$

r = given radius of hose

Example: to make a 180° bend with Thorburn hose which has a 2" I.D.

Given $r = 6$ "

$$\frac{180}{360} [2 \times 3.14 \times 6] = .5 \times 2 \times 3.14 \times 6 = 18.84"$$

Remember that the bend should take place over the entire minimum length and not a portion of it.

NOTE: This formula does not mean 18.84" will be long enough to meet application need. It only means that if the 180° bend takes place in less than 18.84" the flow of fluid or material could be restricted or the hose could be damaged.

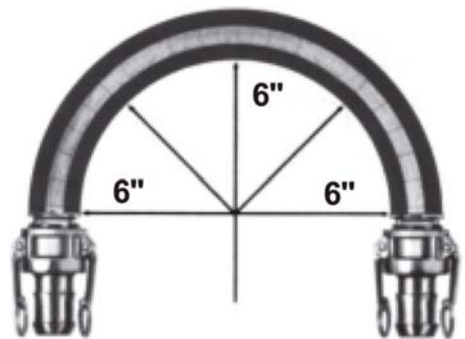

General Maintenance, Testing and Inspection of Hose



Special Procedure

Hose assemblies shall be inspected and tested immediately after the hose is subjected to abnormal abuse such as, severe end pull, flattening or crushing or sharp kinking. As you inspect a hose assembly, remember that most hose failures occur between the coupling and the first three feet along the hose length. Pay close attention to this area. Any hose that has been recoupled shall be proof-tested and inspected before being placed in service.

Hydrostatic Pressure Test

For large bore hose being used in dock service, an inspection card which describes the hose manufacturer, date received, purchase order number and date of installation should be maintained for each hose. The inspection card should be used to record the test results and condition of the hose. Thorburn recommends that new hose assemblies be hydrostatically tested before being placed in service. Hydrostatic testing should be done at periodic intervals to determine if a hose is suitable for continued service. The hydrostatic test and examination shall be conducted in the following manner. Hose to be pressure tested must be restrained by placing steel rods or straps close to each end and at approximate 10 foot (3m) intervals along its length to keep the hose from “whipping” if failure occurs; the steel rods or straps may be anchored firmly to the test structure but in such a manner that they do not contact the hose which must be free to move.

- Hose shall lie in a straight and horizontal position supported on rollers to permit easy movement when under the test pressure.
- Water should be used as the test liquid. Never pressure test with solvents, corrosive liquids, or with compressed gases.
- Fill the hose with water with the outlet end raised and the outlet valve open to insure the complete removal of air. When all the air has been exposed, close the outlet valve and lower the raised end.
- For new hose, raise the pressure to 1 1/2 times the rated working pressure of the hose and hold for 5 minutes. During this hold period, the hose shall be examined for leaks at the couplings, fitting slippage, or for any indication of weakness in the hose structure.
- For used hose, test with a pressure of 1 1/2 times the rated working pressure of the hose and examine as above.

- Completely relieve test pressure from the system prior to releasing hose from test equipment.
- Thoroughly drain the water from the hose after completion of the hydrostatic test.

Electrical Continuity

When required by the user, electrical continuity between the fittings shall be tested using an ohm meter. The hose must be clean and dry for this test.

Hose Assemblies

Hose has a limited life based on the severity and type of chemical contact, environment or exposure to heat and petroleum products. Thorburn recommends the following maintenance procedure to determine when hose should be replaced.

Visual Inspection of Hose

Any cuts, gouges or tears in the cover which do not expose the reinforcement should be repaired before the hose is returned to service. If the reinforcement is exposed, retire the hose from service. Covers may show surface cracking or crazing due to prolonged exposure to sunlight, ozone, or high temperature during soak tank cleaning. Such deterioration, which does not expose reinforcing material, is not cause for retirement. Look for any indication of kinking or broken reinforcement as evidenced by any permanent distortion, longitudinal ridges, or bulges. According to RMA IP-11-7 Chemical Hose Bulletin, crushed or kinked spots where the hose O.D. is reduced by 20% or more of the normal O.D. indicate the hose probably has internal damage. The hose assembly must be removed from service to ensure the safety of people in the work area. Hose containing crushed or kinked spots where the outside diameter is reduced less than 20% may be used if the hose passes the hydrostatic test.

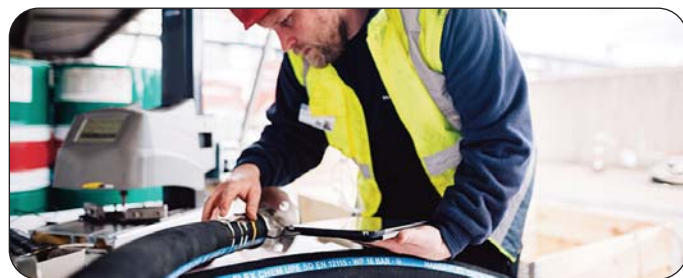

Visual Inspection of Couplings

All metals are subject to attack by various chemicals. Check with Thorburn to make sure that suitable end fittings, appropriate to both the hose and the chemical being handled, are being used. Exposed surfaces of couplings, flanges and nipples shall be examined for cracks or excessive corrosion. Either condition shall cause the hose to be retired from service. Any evidence of coupling or nipple slippage on the hose is cause for removing the hose from service. The Rubber Manufacturers Association has published a series of technical bulletins which detail maintenance, testing and inspection recommendations.

Hose Assembly Maintenance and Storage



Because the life expectancy of the hose is limited, the user must be alert to signs of impending failure, particularly when the conditions of service include high working pressures and/or the conveyance or containment of hazardous materials. The periodic inspection and testing procedures described here provide a schedule of specific measures which constitute a minimum level of user action to detect signs indicating hose deterioration or loss of performance before conditions leading to malfunction or failure are reached.

General instructions are also described for the proper storage of hose to minimize deterioration from exposure to elements or environments which are known to be harmful to rubber products. Proper storage conditions can enhance and extend substantially the ultimate life of hose products.

Safety Warning: Failure to follow properly the manufacturer's recommended procedures for the care, maintenance and storage of a particular hose might result in its failure to perform in the manner intended and might result in possible damage to property and serious bodily injury.

General Care and Maintenance of Hose Assemblies

Hose should not be subjected to any form of abuse in service. It should be handled with reasonable care. Hose should not be dragged over sharp or abrasive surfaces unless specifically designed for such service. Care should be taken to protect hose from severe end loads for which the hose or hose assembly were not designed.

Hose should be used at or below its rated working pressure; any changes in pressure should be made gradually so as to not subject the hose to excessive surge pressures. Hose should not be kinked or be run over by equipment. In handling large size hose, dollies should be used whenever possible; slings or handling rigs, properly placed, should be used to support heavy hose in oil suction and discharge service.

General Test and Inspection Procedures

An inspection and hydrostatic test should be made at periodic intervals to determine if a hose is suitable for continued service. A visual inspection of the hose should be made for loose covers, kinks, bulges, or soft spots which might indicate broken or displaced reinforcement. The couplings or fittings should be closely examined and, if there is any sign of movement of the hose from the couplings, the hose should be removed from service. The periodic inspection of the hose should include a hydrostatic test for one minute at 150% of the recommended working pressure of the hose.

An exception to this would be woven jacketed fire hose.* During the hydrostatic test, the hose should be straight, not coiled or in a kinked position. Water is the usual test medium, and following the test, the hose should be flushed with alcohol to remove traces of moisture. A regular schedule should be followed and inspection records maintained.

*Woven jacketed fire hose should be tested in accordance with the service test provisions contained in the current edition of National Fire Protection Association Bulletin No. 1962— Standard for the Care, Use and Service Testing of Fire Hose, Chapter 5.

Hose Assembly Maintenance and Storage

- Air or any other compressible gas must never be used as the test medium because of the explosive action of the hose should a failure occur. Such a failure might result in possible damage to property and serious bodily injury.
- Air should be removed from the hose by bleeding it through an outlet valve while the hose is being filled with the test medium.
- Hose to be pressure tested must be restrained by placing steel rods or straps close to each end and at approximate 10 foot (3m) intervals along its length to keep the hose from “whipping” if failure occurs; the steel rods or straps are to be anchored firmly to the test structure but in such a manner that they do not contact the hose which must be free to move.
- The outlet end of hose is to be bulwarked so that a blown-out fitting will be stopped.
- Provisions must be made to protect testing personnel from the forces of the pressure media if a failure occurs.
- Testing personnel must never stand in front of in back of the ends of the hose being pressure tested.
- If liquids such as gasoline, oil, solvent, or other hazardous fluids are used as the test fluid, precautions must be taken to protect against fire or other damage should a hose fail and the test liquid be sprayed over the surrounding area.

Safety Warning: Before conducting any pressure test on hose, provision should be made to ensure the safety of the personnel performing the tests and to prevent any possible damage to property. Only trained personnel using proper tools and procedures should conduct any pressure tests.

Storage

Rubber hose products in storage can be affected adversely by temperature, humidity, ozone, sunlight, oils, solvents, corrosive liquids and fumes, insects, rodents and radioactive materials. The appropriate method for storing hose depends to a great extent on its size (diameter and length), the quantity to be stored, and the way in which it is packaged. Hose should not be piled or stacked to such an extent that the weight of the stack creates distortions on the lengths stored at the bottom. Since hose products vary considerably in size, weight and length, it is not practical to establish definite recommendations on this point. Hose having a very light wall will not support as much load as could a hose having a heavier wall or hose having a wire reinforcement. Hose which is shipped in coils or bales should be stored so that the coils are in a horizontal plane.

Storage As Stock

Whenever possible rubber hose products should be stored in their original shipping containers, especially when such containers are wooden crates or cardboard cartons which provide some protection against the deteriorating effects of oils, solvents and corrosive liquids; shipping containers also afford some protection against ozone and sunlight. Certain rodents and insects will damage rubber hose products, and adequate protection from them should be provided. Cotton jacketed hose should be protected against fungal growths if the hose is to be stored for prolonged periods in humidity conditions in excess of 70%. The ideal temperature for the storage of rubber hose products ranges from 50° to 70° F. (10° - 21° C) with a maximum limit of 100° F (38° C.). If stored below 32° (0°C), some rubber products become stiff and would require warming before being placed in service. Rubber products should not be stored near sources of heat , such as radiators, base heaters, etc. Nor should they be stored under conditions of high or low humidity.

To avoid the effects of high ozone concentration, rubber hose products should not be stored near electrical equipment that may generate ozone or be stored for any lengthy period in geographical areas of known high ozone concentration. Exposure to direct or reflected sunlight — even through windows— should also be avoided. Uncovered hose should not be stored under fluorescent or mercury lamps which generate light waves harmful to rubber. Storage areas should be relatively cool and dark, and free of dampness and mildew. Items should be stored on a first-in first-out basis, since even under the best of conditions, an unusually long shelf life could deteriorate certain rubber products.

Storage After Use

After use of a hose assembly, wash thoroughly in cold water to remove any residue. Store the hose on a hose rack with good ventilation away from sunlight in a cool, dry location (Low humidity, 50-70°F). The ends of the hose assemblies should be capped.

Storage Life

It is necessary to perform a complete inspection of a hose assembly before using if it has been stored for a prolonged period as per ISO 8331. To avoid long term storage of hoses, it is recommended to use a scheduled rotation program and keep hose storage to a minimum. The maximum storage life for a hose assembly is two years.

Glossary of Terms

abrasion: a wearing away by friction.

abrasion tester: a machine for determining the quantity of material worn away by friction under specified conditions.

ABS: American Bureau of Shipping.

accelerated life test: a method designed to approximate in a short time the deteriorating effects obtained under normal service conditions.

accelerator: a compounding ingredient used with a curing agent to increase the rate of vulcanization.

acid resistant: having the ability to withstand the action of identified acids within specified limits of concentration and temperature.

activator: a compounding ingredient used to increase the effectiveness of an accelerator.

adapter: the accessory part which can complete the connection between a hose fitting and another fluid system component. Often, a tube fitting connected to a hose assembly rather than a tube assembly.

adhesion: the strength of bond between cured rubber surfaces or between a cured rubber surface and a non-rubber surface.

adhesion failure: (1) the separation of two bonded surfaces at an interface by a force less than specified in a test method; (2) the separation of two adjoining surfaces owing to service conditions.

adhesive: a material which, when applied, will cause two surfaces to adhere.

adhesive coating: a layer applied to any product surface to increase its adherence to an adjoining surface.

aftercure: a continuation of the process of vulcanization after the cure has been carried to the desired degree and the source of heat removed.

afterglow: in fire resistance testing, the red glow persisting after extinction of the flame.

aging: changes in physical properties over a period of time.

air bomb: a chamber capable of holding compressed air heated to an elevated temperature.

air bomb aging: a means of accelerating changes in the physical properties of rubber compounds by exposing them to the action of air at an elevated temperature and pressure.

air checks: the surface markings and depressions which occur due to air trapped between the material being cured and the mold or press surface.

air cure: vulcanization without the application of heat. See also: hot air cure.

air oven aging: a means of accelerating a change in the physical properties of rubber compounds by exposing them to the action of air at an elevated temperature at atmospheric pressure.

ambient temperature: the temperature of the atmosphere or medium surrounding an object under consideration.

angle of lay: the angle developed at the intersection of a structural element and a line parallel to its lineal axis.

ANSI: the abbreviation for the American National Standards Institute, Inc.

antioxidant: a compounding ingredient used to retard deterioration caused by oxygen.

antiozonant: a compounding ingredient used to retard deterioration caused by ozone.

anti-static: see static conductive.

armored hose: a hose with a protective covering, applied as a braid or helix, to protect from physical abuse.

API: American Petroleum Institute

assembly: see hose assembly.

ASTM: the abbreviation for the American Society for Testing and Materials.

autoclave: a pressure vessel used for vulcanizing rubber products by means of steam under pressure.

backing: a rubber layer between a hose tube and/or cover and carcass to provide adhesion (also known as adhesion gum, or friction).

banbury mixer: a specific type of internal mixer used to incorporate fillers and other ingredients into rubber or plastic.

band: (1) a metal ring which is welded, shrunk, or cast on the outer surface of a hose nipple; (2) a thin strip of metal used as a boltless clamp. See also: clamp, hose clamp.

bank: an accumulation of material at the opening between the rolls of a mill or calender. **barb and ferrule fitting:** a two-piece hose fitting comprised of a barbed nipple and ferrule, normally with peripheral ridges or backward-slanted barbs, for inserting into a hose and a ferrule, usually crimped, outside.

bare duck: the duck surface of a hose wherein the exposed duck surface is free of any rubber coating.

batch: the product of one mixing operation.

Glossary of Terms

bench marks (tensile test): marks of known separation applied to a specimen used to measure strain (elongation of specimen).

bench test: a modified service test in which the service conditions are approximated in the laboratory.

bend: the curvature of a hose from a straight line.

bending force: an amount of stress required to induce bending around a specified radius and hence, a measure of stiffness.

bend radius: the radius of a bent section of hose measured to the innermost surface of the curved portion.

BIXA: Boating Industry Association

bias angle: the smaller included angle between the warp threads of a cloth and a diagonal line cutting across the warp threads.

bias cut: a cut of a textile material made diagonally at an angle less than 90° to the longitudinal axis.

bias seam: a seam at which bias cut fabrics are joined together.

binding-in wire: a wire used to anchor a hose to a nipple, usually applied during the construction of the hose. Also called nipple wire.

bite: see nip.

bleeding: surface exudation. See also: bloom.

blister: a raised area on the surface or a separation between layers usually creating a void or air-filled space in a vulcanized article.

block end: see end reinforcement.

bloom: a discoloration or change in appearance of the surface of a rubber product caused by the migration of a liquid or solid to the surface. Examples: sulfur bloom, wax bloom. Not to be confused with dust on the surface from external sources.

body wire: a round or flat wire helix embedded in the hose wall to increase strength or to resist collapse.

bolt hole circle: a circle on the flange face around which the center of the bolt holes are distributed.

bore: (1) an internal cylindrical passageway, as of a tube, hose or pipe; (2) the internal diameter of a tube, hose, or pipe.

bowl: the exterior shell of an expansion ringtype coupling.

braid: a continuous sleeve of interwoven single or multiple strands of yarn or wire.

braid angle: the angle developed at the intersection of a braid strand and a line parallel to the axis of a hose.

braid smash: a defect in a braided reinforcement caused by one or more of the ends of reinforcing material breaking during the braiding operations. Colloquial.

braided hose: hose in which the reinforcing material has been applied as interlaced spiral strands.

braided ply: a layer of braided reinforcement.

braider: a machine which interweaves strands of yarn or wire to make a hose carcass.

braider deck: the base plate upon which the bobbin carriers of a braider machine travel.

braid-over-braid: multiple plies of braid having no separating rubber layers.

brand: a mark or symbol identifying or describing a product and/or manufacturer, either embossed, inlaid or printed.

breaker ply: an open mesh fabric used to anchor a hose tube or cover to its carcass and to spread impact.

BSI: British Standards Institute

buckled ply: a deformation in a ply which distorts its normal plane.

buffing: grinding a surface to obtain dimensional conformance or surface uniformity.

burst: a rupture caused by internal pressure. burst pressure: the pressure at which rupture occurs.

calendar: a machine equipped with three or more heavy, internally heated or cooled rolls revolving in opposite directions, which is used for continuously sheeting, plying up rubber compound, frictioning or coating fabric with rubber compound.

Canadian agencies and organizations: CGA-Canadian Gas Association, CGSB Canadian Government Specifications Board, RAC- Rubber Association of Canada.

capped end: a hose end covered to protect its internal elements.

carcass: the fabric, cord and/or metal reinforcing section of a hose as distinguished from the hose tube or cover.

cement: unvulcanized raw or compounded rubber in a suitable solvent used as an adhesive or sealant.

cemented end: a hose end sealed with the application of liquid coating.

CGA: Canadian Gas Association, and the abbreviation for U.S. organization, Compressed Gas Association

Glossary of Terms

CGSB: Canadian Government Specifications Board

chafer duck: a duck of approximately square woven construction made with single or ply yarn warp and filling.

chalking: the formation of a powdery surface condition due to disintegration of surface binder or elastomer by weathering or other destructive environments.

charge mark: see lead stop.

checking: the short, shallow cracks on the surface of a rubber product resulting from damaging action of environmental conditions.

chernack loom: a four shuttle circular loom for the production of seamless hose reinforcement.

churn: a vessel used for making rubber cement, in which rubber compounds are stirred into solvents.

C I: in hose, an abbreviation for "cloth inserted," a term applied to low strength small diameter hose reinforced with a ply or plies of lightweight fabric.

C I tubing: a small diameter hose reinforced with a ply or plies of lightweight fabric. Colloquial.

circular woven jacket: a textile reinforcing member produced on a circular loom for such types of hose as fire hose.

clamp: in hose, a metal fitting or band used around the outside of a hose end to bind the hose to a coupling, fitting or nipple.

cloth impression: see fabric impression.

cold feed: the introduction of compounded rubber into extrusion processing equipment without milling.

cold flex: see low temperature flexibility.

cold flexibility: the relative ease of bending following exposure to specified low temperature conditioning.

cold flow: continued deformation under stress.
See also: creep and drift.

commercially smooth: a degree of smoothness of an article which is acceptable in accordance with industry practice.

compound: the mixture of rubber or plastic and other materials which are combined to give the desired properties when used in the manufacture of a product.

compound ingredient: a material added to a rubber to form a mix.

compound material: a substance used as part of a rubber mix.

compression set: the deformation which remains in rubber after it has been subjected to and released from a specific compressive stress for a definite period of time at a prescribed temperature. (Compression set measurements are for the purpose of evaluating creep and stress relaxation properties of rubber).

conditioning: the exposure of a specimen under specified conditions, e.g., temperature, humidity, for a specified period of time before testing.

concentricity: the uniformity of hose wall thickness as measured in a plane normal to the axis of the hose.

conductive: a rubber having qualities of conducting or transmitting heat or electricity. Most generally, applied to rubber products capable of conducting static electricity.

control: a product of known characteristics which is included in a series of tests to provide a basis for evaluation of other products.

copolymer: a polymer formed from two or more types of monomers.
cord breaker: an openly spaced cord fabric to spread impact or to improve cover adhesion or both.

corrugated cover: a longitudinally ribbed or grooved exterior.

corrugated hose: hose with a carcass fluted radially or helically to enhance its flexibility or reduce its weight.

count: in fabric, the number of warp ends, or the number of filling picks, or both, in a square inch of fabric.

coupled length: see hose assembly.

coupling: a frequently used alternative term for fitting.

cover: the outer component usually intended to protect the carcass of a product.

cover seam: the spiral or longitudinal joint formed by the lapping of hose cover stock.

cover wear: the loss of material during use due to abrasion, cutting or gouging.

cracking: a sharp break or fissure in the surface. Generally caused by strain and environmental conditions.

crazing: a surface effect on rubber articles characterized by multitudinous minute cracks.

creep: the deformation, in either cured or uncured rubber under stress, which occurs with lapse of time after the immediate deformation.
See also: cold flow, and drift.

Glossary of Terms

crimp: in fabric, (1) the sinusoidal curvature impressed in the warp or filling during weaving; (2) the difference in distance between two points on a yarn as it lies in a fabric, and the same two points when the yarn has been removed from the fabric and straightened under tension.

crimping: the act of forming a hose fitting with a surrounding series of die segments to compress the hose within the fitting.

crosshead extruder: an extruder so constructed that the axis of the emerging extruded product is at right angles to the axis of the extruder screw. Commonly used for applying the cover to braided or spiraled hose.

cross-link: chemical bond bridging one polymer chain to another.

cross wrap: the overlapping layer or layers of narrow tensioned wrapper fabric spiraled circumferentially over the outside of a hose to obtain external pressure during vulcanization. See also: wrapped cure.

crystallization (polymer): an arrangement of previously disordered polymer segments of repeating patterns into a geometric symmetry (which results in a reversible hardening of a rubber compound).

cubical expansion: the volume increase of hose when subjected to internal pressure. It is generally reported in cubic centimeters per unit length of hose.

cure: the act of vulcanization. See also: vulcanization.

cure time: the time required to produce vulcanization at a given temperature. cut resistant: having that characteristic of withstanding the cutting action of sharp objects.

date code: any combination of numbers, letters, symbols or other methods used by a manufacturer to identify the time of manufacture of a product.

denier: a yarn sizing system for continuous filament synthetic fibers. The denier of filament yarn is the weight in grams of a length of 9000 meters of that yarn.

density: the mass per unit of volume of a material.

design factor: a ratio used to establish the working pressure of the hose, based on the burst strength of the hose.

dielectric strength: the measure of a product's ability to resist passage of a disruptive discharge produced by an electric stress.

DIN: Deutsches Institute for Normung-German National Standards Organization.

DOD: Department of Defense (U.S.)

DOT: Department of Transportation (U.S.)

drift: a change in a given hardness value after a specified period of time.

dry: the absence of tack; no adhering properties.

duck: a term applied to a wide range of medium and heavy-weight woven fabrics.

durometer: an instrument for measuring the hardness of rubber and plastic compounds.

durometer hardness: a numerical value which indicates the resistance to indentation of the blunt indenter of the durometer.

eccentricity: in hose, tubing or cylindrical articles, the condition resulting from the inside and outside diameters not having a common center. See also eccentric wall and off-center.

eccentric wall: in hose or tubing, a wall of varying thickness.

elastic limit: the limiting extent to which a body may be deformed and yet return to its original shape after removal of the deforming force.

elastomer: macromolecular material which returns rapidly to approximately its initial dimensions and shape after substantial deformation by a weak stress and release of the stress; an elastic polymer.

elongation: the increase in length expressed numerically as a fraction or percentage of the initial length.

EN: European Norms

end: a single strand or one of several parallel strands of a reinforcing material on a single package such as a braider spool.

end block: see end reinforcement.

end reinforcement: extra reinforcing material applied to the end of a hose product to provide additional strength or stiffening.

ends: see fabric count.

endurance test: a service or laboratory test, conducted to product failure, usually under normal use conditions.

enlarged end: in hose, an end having a bore diameter greater than that of the main body of the hose in order to accommodate a larger fitting.

extruded: forced through the shaping die of an extruder. The extrusion may be solid or hollow cross section.

extruder: a machine, generally with a driven screw, for continuous forming of rubber or plastic through a die. It is widely used for the production of hose tubes.

fabric: a planar structure produced by interlaced yarns, fibers or filaments.

fabric count: the number of warp ends per inch, and the number of filling picks per inch.

Glossary of Terms

fabric impression: a pattern in the rubber surface formed by contact with fabric during vulcanization.

fabric picks/inch: the number of filling (weft) yarns per inch.

fatigue: the weakening or deterioration of a material occurring when a repetitious or continuous application of stress causes strain.

FDA: Food and Drug Administration (U.S.)

ferrule: a collar placed over a hose end to affix the fitting to the hose. The ferrule may be crimped or swaged, forcing the hose in against the shank of the fitting, or the shank may be expanded, forcing the hose out against the ferrule, or both.

filament: textile fiber of indefinite or extreme length.

filler: (1) any compounding material, usually in powder form, added to rubber in a substantial volume to improve quality or lower cost; (2) the material added during hose fabrication to fill gaps or voids between turns of body wire; (3) improperly used in place of "filling" to denote the transverse strength member in a circular woven reinforcement.

filling threads: the threads of yarns running at right angle to the warp.

fitting: a device attached to the end of the hose to facilitate connection.

flange-fitting: a circular ring at the end of a hose or hose assembly for joining to another circular ring, generally by bolting; may be a rubber member integral with the hose or a metal ring attached to a pipe nipple.

flat cure: a method of curing fire hose in a flat form.

flat spots: flat areas on the surface of cured hose caused by deformation during vulcanization.

flat wire: the rectangular cross-section wire commonly used as the inner element of rough bore suction hose.

flex cracking: a surface cracking induced by repeated bending and straightening.

flexible mandrel: a long, round, smooth rod capable of being coiled in a small diameter. It is used for support during the manufacture of certain types of hose. (The mandrel is made of rubber or plastic material and may have a core of flexible wire to prevent stretching.)

flex life: the relative ability of a rubber article to withstand cyclical bending stresses.

flex life test: a laboratory method used to determine the life of a rubber product when subjected to dynamic bending stresses.

flow crack: a surface imperfection caused by improper flow and failure of stock to knit or blend with itself during the molding operation.

flow line: see flow mark.

flow mark: a surface imperfection similar to a flow crack, but the depression is not quite as deep.

flow rate: a volume of fluid per unit of time passing a given cross-section of a flow passage in a given direction.

FM: Factory Mutual Research foreign material: any extraneous matter such as wood, paper, metal, sand, dirt or pigment that should not normally be present in the tube or cover of a hose.

formula: a list of ingredients and their amount, used in the preparation of a compound.

free length: the lineal measurement of hose between fittings or couplings.

freeze resistant: see cold resistant.

friction: (1) a rubber adhesive compound impregnating a fabric, usually applied by means of a calendar with rolls running at different surface speeds (the process is called "frictioning"); (2) the resistance to motion due to the contact of surfaces; (3) erroneously used to denote adhesion, or degree of adhesion.

friction coating: a rubber covering applied to the weave of a fabric simultaneously with impregnation.

friction surface: the exposed portion of a hose formed by a layer of rubber impregnated fabric as distinguished from a product having the fabric completely covered with a layer of rubber.

frictioned fabric: a fabric impregnated with a rubber compound by friction motion (calendar rolls running at different surface speeds).

frosting: see chalking.

fungicide: a material that prevents or retards the growth of fungi.

grab test: a tensile test for woven fabric using specimens considerably wider than the jaws holding the ends of the test specimen.

grain: the unidirectional orientation of rubber or filler particles resulting in anisotropy of rubber compounds.

ground finish: a surface produced by grinding or buffing.

gum compound: a rubber compound containing only those ingredients necessary for vulcanization. Small amounts of other ingredients may be added for processability, coloring, and improving resistance to aging.

hand-built hose: a hose made by hand on a mandrel, reinforced by textile or wire or combination of both.

Glossary of Terms

hank: (1) a skein of yarn; (2) a standard length of yarn. The length is specified by the yarn numbering system in use, e.g., cotton hanks have a length of 840 yards.

hardening: an increase in resistance to indentation.

hardness: resistance to indentation. See also durometer hardness.

hawser twist: a cord or rope construction in which the first and second twists are in the same direction while the third twist is in the opposite direction, i.e., S-S-Z.

heat resistance: the property or ability to resist the deteriorating effects of elevated temperatures.

helical cord: in hose, a reinforcement formed by a cord or cords wound spirally around the body of a hose.

helix: in hose, a shape formed by spiraling a wire or other reinforcement around the cylindrical body of a hose.

herringbone wrap: a narrow herringbone woven tape spiraled circumferentially over the outside of the product to apply external pressure during vulcanization. See also wrapped cure.

Higbee: the thread of a hose coupling, the outermost convolution of which has been removed to such an extent that a full cross section of the thread is exposed, this exposed end being beveled.

hold test: a hydrostatic pressure test in which the hose is subjected to a specified internal pressure for a specified period of time.

hose: a flexible conduit consisting of a tube, reinforcement, and usually an outer cover.

hose assembly: a length of hose with a coupling attached to one or each end.

hose clamp: a collar, band or wire used to hold hose on to a fitting, See also: clamp, ferrule.

hose duck: a woven fabric made from plied yarns with approximately equal strength in warp and filling directions.

hot air cure: vulcanization by using heated air, with or without pressure, See also: air cure, vulcanization.

hysteresis: a loss of energy due to successive deformation and relaxation. It is measured by the area between the deformation and relaxation stress-strain curves.

hysteresis loop: in general, the area between stress-strain curves of increasing and reducing stress; a measure of hysteresis.

ID: the abbreviation for inside diameter.

identification yarn: a yarn of single or multiple colors, usually embedded in the hose wall, used to identify the manufacturer.

immediate set: the amount of deformation measured immediately after removal of the load causing the deformation.

impregnation: the act of filling the interstices of an article with a rubber compound. Generally applies to the treatment of textile fabrics and cords.

impression: a design formed during vulcanization in the surface of a hose by a method of transfer, such as fabric impression or molded impression, impression, fabric: impression formed on the rubber surface during vulcanization by contact with fabric jacket or wrapper.

impulse: an application of force in a manner to produce sudden strain or motion, such as hydraulic pressure applied in a hose.

indentation: (1) the extent of deformation by the indenter point of any one of a number of standard hardness testing instruments; (2) a recess in the surface of a hose.

inhibitor: an ingredient used to suppress a chemical reaction or a growing activity such as mildew.

insert: optional term for nipple (see nipple).

inspection block: a description on a drawing of the dimensional inspection to which a hose will be subjected.

instantaneous modulus: the slope of a stress-strain curve at a single point, employed when modulus varies from point to point.

interstice: a small opening, such as between fibers in a cord or threads in a woven or braided fabric.

intrinsic viscosity: the ratio of the difference of the viscosity of the solution, at the given concentration and the viscosity of the pure solvent to the product of the viscosity of the pure solvent and the volume concentration of the solution.

IPT: the abbreviation for standard iron pipe thread.

ISO: the abbreviation for the International Organization for Standardization.

jacket: (1) a seamless tubular braided or woven ply generally on the outside of a hose; (2) a woven fabric used during vulcanization by the wrapped cure method.

kinking: a temporary or permanent distortion of the hose induced by bending beyond the minimum bend radius.

knit fabric: a flat or tubular structure made from one or more yarns or filaments whose direction is generally transverse to the fabric axis but whose successive passes are united by a series of interlocking loops.

Glossary of Terms

knit ply: a layer of textile reinforcement in which the yarns are applied in an interlocking looped configuration in a continuous tubular structure.

knitter: a machine for forming a fabric by the action of needles engaging threads in such a manner as to cause a sequence of interlaced loops (Interlaced loops forming a continuous tubular structure are commonly used as hose reinforcement).

laminated cover: a cover formed to desired thickness from thinner layers vulcanized together.

lap: a part that extends over itself or like part, usually by a desired and predetermined amount.

lap seam: a seam made by placing the edge of one piece of material extending flat over the edge of the second piece of material.

lay: (1) the direction of advance of any point in a strand for one complete turn (2) the amount of advance of any point in a strand for one complete turn. See also: pitch, spiral lay.

layer: a single thickness of rubber or fabric between adjacent parts.

lead burst: a leak in lead press hose during vulcanization caused by a rupture of the lead casing.

lead casing: the extruded lead tube or sheath which confines the hose during vulcanization.

lead chip mark: a minor nick or mark in the surface of the cover of lead finished hose caused by particles of lead flakes sloughing off the lead extrusion die during the process of lead covering.

lead cure finish: a type of exterior surface, either ribbed, smooth, or longitudinally corrugated, obtained by the lead pipe mold method of vulcanization.

lead dent: an indentation in the surface of lead finished hose caused by deformations in lead covering before vulcanization.

lead die mark: the longitudinal line or mark in the cover of lead finished hose caused by a damaged lead extrusion pin.

lead discoloration: a dark stain on the colored cover of lead finished hose caused by a chemical reaction of the lead with the rubber compound.

lead flake: a particle of lead which remains on the cover of lead finished hose after the lead covering has been stripped from the hose.

lead pop: a surface protrusion, the result of a rupture of lead sheath during vulcanization.

lead press cure: a near-obsolete process wherein a lead sheath acts as a restraining member or mold during vulcanization.

lead press finish: the type of exterior surface obtained by the lead press method of vulcanization.

lead press joint: see lead stop.

lead stop: the mold mark in a lead press hose cover caused by stopping the lead press to add another lead billet.

leaker: (1) a crack or hole in the tube which allows fluids to escape; (2) a hose assembly which allows fluids to escape at the fittings or couplings.

legs: tension filaments appearing when cemented or frictioned plies are pulled apart. Colloquial.

leno breaker: an open mesh fabric made from coarse ply yarns, with a leno weave. See also: breaker ply.

leno weave: a fabric structure in which the warp yarns are bound in by the filling, resulting in an open perforated fabric.

life test: a laboratory procedure used to determine the resistance of a hose to a specific set of destructive forces or conditions. See also: accelerated life test.

light resistance: the ability to retard the deleterious action of light.

lined bolt holes: the bolt holes which have been given a protective coating to cover the internal structure.

lined hose: term generally referring to fire hose having a seamless woven jacket or jackets and a tube.

liner: a separator, usually cloth, plastic film or paper, used to prevent adjacent layers of material from sticking together.

lining: see tube.

livering: a gelling in cement giving a liver-like consistency.

loop edge: a selvage formed by having the filling loop around a catch cord or wire which is later withdrawn, leaving small loops along the edge of the cloth.

loop-edge tape: a tape woven with a selvage edge formed by looping the filling threads to prevent raveling, allowing extensibility for even tensions.

loose cover: a separation of the cover from the carcass or reinforcements.

loose ply: a separation between adjacent plies.

loose tube: a tube separated from the carcass.

Glossary of Terms

lot: a specified quantity of hose from which a sample is taken for inspection.

low temperature flexibility: the ability of a hose to be flexed, bent or bowed at low temperatures without loss of serviceability.

low temperature flexing: the act of bending or bowing a hose under conditions of cold environment.

LPG: the abbreviation for liquefied petroleum gas.

machine made: a mandrel-built reinforced hose made by machine as opposed to hose built by hand.

mandrel: a form, generally of elongated round section, used for size and to support hose during fabrication and/or vulcanization. It may be rigid or flexible.

mandrel built: a hose fabricated and/or vulcanized on a mandrel.

mandrel wrapped: a tubing, built up by wrapping a thick unvulcanized sheet around a mandrel.

manufacturer's identification: a code symbol used on or in some hose to indicate the manufacturer.

mass flow rate: the mass of fluid per unit of time passing a given cross-section of a flow passage in a given direction.

master batch: a preliminary mixture of rubber and one or more compound ingredients for such purposes as more thorough dispersion or better processing, and which will later become part of the final compound in a subsequent mixing operation.

migration: in a rubber compound, the movement of more or less rubber soluble materials from a point of high concentration to one of low or zero concentration. Migration is applied to the movement of accelerators, antioxidants, antiozonants, sulphur, softeners and organic colors. It is a form of diffusion.

migration stain: a discoloration of a surface by a hose which is adjacent to but not touching the discolored surface.

mildew inhibited: containing material to prevent or retard the propagation of a fungus growth.

mildew resistance: withstanding the action of mildew and its deteriorating effect.

mill: a machine with two horizontal rolls revolving in opposite directions used for the mastication or mixing of rubber.

minimum burst pressure: the lowest pressure at which rupture occurs under prescribed conditions.

mix: see compound.

modulus: in the physical testing of rubber, the load necessary to produce a stated percentage of elongation, compression or shear.

moisture absorption: the assimilation of water by a rubber or textile product.

moisture regain: the re absorption of water by textile.

monomer: a low molecular weight substance consisting of molecules capable of reacting with like or unlike molecules to form a polymer.

Mooney scorch: a measure of the incipient curing characteristics of a rubber compound using the Mooney viscometer.

Mooney viscosity: a measure of the plasticity of a rubber or rubber compound determined in a Mooney shearing disc viscometer.

MPa: megapascal a measure of pressure, one MPa equals 145 psi

MSHA: Mine Safety and Health Administration

NAHAD: National Association of Hose and Accessories Distributors

necking down: a localized decrease in the cross-sectional area of a hose resulting from tension.

nerve: a measure of toughness or recovery from deformation in unvulcanized rubbers or compounds.

NFPA: National Fluid Power Association, also National Fire Protection Association.

NHTSA: National Highway Traffic Safety Administration

nip: the clearance between rolls of a mixing mill or calendar.

nipple: the internal member or portion of a hose fitting.

nominal: a dimensional value assigned for the purpose of convenient designation; existing in name only.

nozzle end: an end of hose in which both the inside and outside diameters are reduced.

OD: the abbreviation for outside diameter. off-center: see eccentricity. off gauge: not conforming to a specified thickness.

oil proof: not affected by exposure to oil.

oil swell: the change in volume of a rubber article resulting from contact with oil.

open seam: a seam whose edges do not meet, creating a void.

open steam cure: a method of vulcanizing in which steam comes in direct contact with the product being cured.

Glossary of Terms

operating pressure: see working pressure.

optimum cure: the state of vulcanization at which a desired combination is attained.

OS & D hose: the abbreviation for oil suction and discharge hose.

OSHA: Occupational Safety and Health Administration.

overcure: a state of vulcanization beyond the optimum cure.

oxidation: the reaction of oxygen on a rubber product, usually evidenced by a change in the appearance or feel of the surface or by a change in physical properties.

oxygen bomb: a chamber capable of holding oxygen at an elevated pressure which can be heated to an elevated temperature. Used for an accelerated aging test.

oxygen bomb aging: a means of accelerating a change in the physical properties of rubber compounds by exposing them to the action of oxygen at an elevated temperature and pressure.

ozone cracking: the surface cracks, checks, or crazing caused by exposure to an atmosphere containing ozone.

ozone resistance: the ability to withstand the deteriorating effects of ozone (generally cracking).

peptizer: a compounding ingredient used in small proportions to accelerate by chemical action the softening of rubber under the influence of mechanical action, heat, or both.

performance test: see service test.

permanent fitting: the type of fitting which, once installed, may not be removed for use in another hose.

permanent set: the amount by which an elastic material fails to return to its original form after deformation.

PHA: Public Health Administration

photographing: a bas-relief or outline of a reinforcement which appears on the cover of a hose after vulcanization. Also called "profiling."

pick: an individual filling yarn of a fabric or woven jacket.

pitch: the distance from one point on a helix to the corresponding point on the next turn of the helix, measured parallel to the axis. See also: spacing.

pitted tube: surface depressions on the inner tube of a hose.

plain ends: the uncapped, or otherwise unprotected, straight ends of a hose.

plasticity: (1) a measure of the resistance to shear of an unvulcanized elastomer; (2) a property of vulcanized rubber to retain a shape or form imparted to it by a deforming force.

plasticizer: a compounding ingredient which can change the hardness, flexibility, or plasticity of an elastomer.

plastometer: (1) an instrument for measuring the viscosity of raw or unvulcanized rubber; (2) an instrument for measuring the hardness of vulcanized rubber.

plied yarn: a yarn made by twisting together in one operation two or more single yarns.

ply: (1) a layer or rubberized fabric; (2) a layer formed by a single pass through a single deck of a yarn, cord, or wire braiding machine; (3) a layer formed by a single pass through a single head of yarn, cord, or wire knitting machine; (4) a seamless woven jacket consisting of warp and filler yarns and/or wire; (5) a layer consisting of multiple strands of cord or wire closely spaced; (6) a layer formed by winding a single strand of cord or wire closely spaced; (7) a single yarn in a composite yarn; (8) a layer of unvulcanized rubber.

ply adhesion: the force required to separate two adjoining reinforcing members of a hose.

ply separation: a loss of adhesion between plies.

pock marks: uneven blister-like elevations, depressions, or pimpled appearance.

polymer: a macromolecular material formed by the chemical combination of monomers having either the same or different chemical composition.

popcorn: a term common to steam hose where small eruptions within the tube wall rip or tear material, leaving cavities in the tube.

porous tube: (1) the physical condition of a hose tube due to the presence of pores; (2) a hose tube that has low resistance to permeation.

pre-cure: see semi-cure and scorch.

preproduction inspection or test: the examination of samples from a trial run of hose to determine adherence to a given specification, for approval to produce.

pressure, burst: the pressure at which rupture occurs.

pressure, operating: see: working pressure.

pressure, proof: a specified pressure which exceeds the manufacturer's recommended working pressure applied to a hose to indicate its reliability at normal working pressure. Proof pressure is usually twice the working pressure.

pressure, service: see: working pressure.

Glossary of Terms

pressure, working: the maximum pressure to which a hose will be subjected, including the momentary surges in pressure which can occur during service. Abbreviated as WP.

pricker mark: a perforation of the cover of a hose performed before or after vulcanization.

printed brand: see brand.

processability: the relative ease with which raw or compounded rubber can be handled in or on rubber processing machinery.

pressure, operating: see: working pressure.

pressure, proof: a specified pressure which exceeds the manufacturer's recommended working pressure applied to a hose to indicate its reliability at normal working pressure. Proof pressure is usually twice the working pressure.

pressure, service: see: working pressure.

pressure, working: the maximum pressure to which a hose will be subjected, including the momentary surges in pressure which can occur during service. Abbreviated as WP.

pricker mark: a perforation of the cover of a hose performed before or after vulcanization.

printed brand: see brand.

processability: the relative ease with which raw or compounded rubber can be handled in or on rubber processing machinery.

proof pressure: a specified pressure which exceeds the manufacturer's recommended working pressure applied to a hose to indicate its reliability at normal working pressure. Proof pressure is usually twice the working pressure.

proof pressure test: a non-destructive pressure test applied to a hose to determine its reliability at normal working pressures by applying pressures which exceed the manufacturer's rated working pressure.
psi: the abbreviation for pounds per square inch.

pulled-down tube: see loose tube.

pure gum: a rubber compound containing only those ingredients necessary for vulcanization; particularly applicable to natural rubber.

qualification test: the examination of samples from a typical production run of hose to determine adherence to a given specification; performed for approval as a supplier.

quality conformance inspection or test: the examination of samples from a production run of hose to determine adherence to given specifications, for acceptance of that production run.

RAC: the abbreviation for the Rubber Association of Canada.

rag-wrap: see wrapped cure.

recovery: the degree to which a hose returns to its normal dimensions or shape after being distorted.

reinforcement: (1) the strengthening members, consisting of either fabric, cord, and/or metal, of a hose; (2) the non-rubber elements of a hose. See also: carcass

reinforcing agent: an ingredient (not basic to the vulcanization process) used in a rubber compound to increase its resistance to mechanical forces.

resin: a compounding material, solid or liquid in form, used to modify the processing and/or vulcanized characteristics of a compound.

retarder: a compounding ingredient used to reduce the tendency of a rubber compound to vulcanize prematurely.

reusable coupling: see reusable fitting.

reusable fitting: the type of fitting which, by design, may be removed and reused.

reversion: the softening of vulcanized rubber when it is exposed to an elevated temperature; a deterioration in physical properties. (Extreme reversion may result in tackiness.)

rise test: a determination of the distance a fire hose, under a specified internal pressure, lifts from the surface on which it rests.

roll ratio: the ratio of the surface speeds of two adjacent mill or calendar rolls.

RMA: the abbreviation of The Rubber Manufacturers Association.

rough bore hose: a wire reinforced hose in which a wire is exposed in the bore.

rubber: elastomer which can be, or already is, modified to a state in which it is essentially insoluble (but can swell) in boiling solvent, such as benzene, methyl ethyl ketone and ethanol-toluene azeotrope, and which in its modified state cannot be easily remoulded to a permanent shape by the application of heat and moderate pressure.

rubber cement: see cement.

SAE: Society of Engineers

safety factor: see design factor.

sampling: a process of selecting a portion of a quantity of a hose for testing or inspection, selected without regard to quality.

Glossary of Terms

scorch: premature vulcanization of a rubber compound.

screw-together reusable fitting: a type of hose fitting whose SOCKET and NIPPLE are threaded together in combination with the hose.

seam: a line formed by the joining of the edges of a material to form a single ply or layer.

seaming strip: a strip of material laid over a seam to act as a binder.

self cure: see air cure.

selvage: the lengthwise woven edge of a fabric. Also called selvedge.

semi-cure: a preliminary but incomplete cure applied to a tube or hose in the process of manufacture to cause the tube or hose to acquire a degree of stiffness or to maintain some desired shape.

service pressure: see working pressure.

service test: a test in which the product is used under actual service conditions.

set: the amount of strain remaining after complete release of a load producing a deformation.

shank: that portion of a fitting, which is inserted into the bore of a hose.

shear modulus: the ratio of the shear stress to the resulting shear strain (the latter expressed as a fraction of the original thickness of the rubber measure, at right angles to the force) Shear modulus may be either static or dynamic.

shelf storage life: the period of time prior to use during which a product retains its intended performance capability.

shell: see ferrule.

shock load: a stress created by a sudden force.

simulated service test: see bench test

sink: a collapsed blister or bubble leaving a depression in a product.

skim coat: a layer of rubber material laid on a fabric but not forced into the weave Normally laid on a frictioned fabric, Sometimes called skim.

skimmed fabric: a fabric coated with rubber on a calender. The skim coat may or may not be applied over a friction coat.

skive: (1) a cut made at an angle to the surface of a sheet of rubber to produce a tapered or leathered cut (2) the removal of a short length of cover to permit the attachment of a fitting directly over the hose reinforcement.

smooth bore hose: a wire reinforced hose in which the wire is not exposed on the inner surface of the tube.

smooth cover: a cover having an even and uninterrupted surface; a commercial finish.

socket: the external member or portion of a hose fitting, commonly used in describing screw-together reusable fittings.

soft end: a hose end in which the rigid reinforcement of the body, usually wire, is omitted.

spacing: the space between adjacent turns of helically wound wire. (Differs from "pitch" in that the diameter or width of wire is not included.)

specification: a document setting forth pertinent details of a product, such as performance, chemical composition, physical properties and dimensions, prepared for use in, or to form the basis for, an agreement between negotiating parties.

specific gravity: the ratio of the weight of a given substance to the weight of an equal volume of water at a specified temperature.

specimen: an appropriately shaped and prepared sample, ready for use in a test procedure.

spider mark: (1) a cleavage or weak spot caused by the failure of a compound to reunite after passing a spoke of the spider of an extrusion machine; (2) the grain produced at point of joining of stock after passing the spoke of the spider of an extrusion machine.

spiral: a method of applying reinforcement in which there is no interlacing between individual strands of the reinforcement.

spiral lay: the manner in which a spiral reinforcement is applied with respect to angularity and lead or pitch as in a hose or cylindrical article. See also angle of lay.

splice: a joint or junction made by lapping or butting, straight or on a bias, and held together through vulcanization or mechanical means.

spread: a thin coat of material in solvent form applied on a fabric surface by means of knife, bar or doctor blade.

spread fabric: a fabric the surface of which is coated with a rubber solution and dried.

spring guard: a helically wound wire applied internally or externally to reinforce the end of a hose.

stain: see migration stain.

standard: a document, or an object for physical comparison, for defining product characteristics, products, or processes, prepared by a consensus of a properly constituted group of those substantially affected and having the qualifications to prepare the standard for use.

Standards Organizations: ABS-American Bureau of Shipping, ANSI-American National Standards Institute, API-American Petroleum Institute, ASTM-American Society for Testing and Materials, BIA-Boating

Glossary of Terms

Industry Association, BSI-British Standards Institute, CGA-Compressed Gas Association, DIN Deutsches Institute for Normung-German Standards, EN-European Norms, FPS-Fluid Power Society, FM- Factory Mutual Research,

ISO-International Organization for Standardization, JIS-Japanese Industrial Standards, NAHAD-National Association of Hose and Accessories Distributors, NFPA National Fluid Power Association, RMA Rubber Manufacturers Association, SAE Society of Automotive Engineers, TFI-The Fertilizer Institute, UL- Underwriters Laboratories.

staple: (1) textile fiber of relatively short length when spun and twisted forms a yarn; (2) the length of such a textile fiber.

static bonding: use of a grounded conductive material to eliminate static electrical charges.

static conductive: having the capability of furnishing a path for a flow of static electricity.

static wire: a wire incorporated in a hose to conduct static electricity.

stock: an uncured rubber compound of a definite composition from which a given article is manufactured.

straight end: a hose end with an inside diameter the same as that of the main body of the hose.

straight wrap: in a curing process, a wrap of lightweight fabric in which the warp threads of the fabric are parallel to the axis of the hose.

stress relaxation: the decrease in stress after a given time at constant strain.

stress-strain: the relationship of force and deformation of a unit area of a body during compression, extension or shear.

stretch: (1) an increase in dimension; an elongation; (2) the end load applied to fire hose during vulcanization to reduce hose elongation.

strike through: (1) in coated or frictioned fabric, a penetration of rubber compound through the fabric, (2) in woven fire hose, the penetration of the rubber backing through the jacket.

stripper cuts: the longitudinal cuts in the cover of lead finished hose caused by an improperly set stripper knife.

strip test: in fabric testing, tensile strength test made on a strip of fabric raveled down to a specified number of threads or width of fabric, all of which are firmly held in grips wider than the test piece.

sulfur, free: the sulfur in a rubber compound extractable by sodium sulfite after the normal vulcanization process.

sulfur, total: all the sulfur present in a rubber compound, including inorganic sulfides and sulfates.

sun checking: the surface cracks, checks, or crazing caused by exposure to direct or indirect sunlight.

surge: a rapid and transient rise in pressure.

swaging: the act of forming a hose fitting by passing it into a die, generally split, which is sized to yield the desired finished fitting diameter.

swelling: an increase in volume or linear dimension of a specimen immersed in liquid or exposed to a vapor.

tabby: a section of cord fabric with closely woven pick yarns. enabling the woven cord to be cut without the individual cords in the rest of the roll becoming displaced.

tack: the ability to adhere to itself: an adhesive quality or condition.

tack, rubber: a property of a rubber and rubber compounds that causes two layers of compounds that have been pressed together to adhere firmly at the area of contact.

tear resistance: the property of a rubber tube or cover of a hose to resist tearing forces.

teeth: the tension filaments which appear between two adhering plies of rubber as they are pulled apart.

tensile strength: the maximum tensile stress applied while stretching a specimen to rupture.

tensile stress: a stress applied to stretch a test piece (specimen).

test pressure: see proof pressure test.

tex: a yarn size system defined as the weight in grams of 1000 meters of yarn.

textile: (1) the general term applied to that which is or maybe woven, as a woven cloth or yarn, (2) a fibrous material suitable for being spun and woven into cloth or yarn.

TFI: The Fertilizer Institute.

thin cover: (1) a cover, the thickness of which is less than specified; (2) a wire braid hydraulic hose specifically made with a thin cover to eliminate the need for buffing when attaching couplings.

thin tube: a lining the thickness of which is less than specified.

tight braid: (1) an unevenness in a braid reinforcement caused by one or more ends of the reinforcement being applied at a greater tension than the remaining ends; (2) a localized necking down of the braided reinforcement caused by a stop in the braiding operation.

tolerance: (1) the upper and lower limits between which a dimension must be held; (2) the total range of variation, usually bilateral, permitted for a size, position or other required quantity.

Glossary of Terms

trapped air: air trapped during cure (which usually causes a loose ply or cover, a surface mark, depression or void.)

tube: the innermost continuous all-rubber or plastic element of a hose tubing; a non-reinforced, flexible, homogeneous conduit, generally of circular cross-section.

tubing machine: see extruder

twist: (1) the turns about the axis, permit of length, of a fiber, roving yarn, card, etc. Twist is usually expressed as turns per inch; (2) the turn about the axis of a hose subjected to internal pressure.

UL: Underwriters Laboratories ultimate strength: see tensile strength.

under cure: a less than optimal state of vulcanization, which may be evidenced by tackiness or inferior physical properties.

USCG: U.S. Coast Guard.

USDA: U.S. Department of Agriculture. U.S. Government agencies DOD- Department of Defense, DOT Department of Transportation, FDA-Food and Drug Administration, MSHA-Mine Safety and Health Administration, OSHA- Occupational Safety and Health Administration, PHA- Public Health Administration, USCG- U.S. Coast Guard, USDA- U.S. Department of Agriculture.

viscosity: the resistance of a material to flow under stress.

void: the absence of material or an area devoid of materials where not intended. See also: blister, sink.

volume change: a change in linear dimensions of a specimen immersed in a liquid or exposed to a vapor.

volume swell: see swelling.

vulcanization: an irreversible process during which a rubber compound, through a change in its chemical structure (e.g. cross-linking), becomes less plastic and more resistant to swelling by organic liquids, and which confers, improves or extends elastic properties over a greater range of temperature.

warp: (1) the lengthwise yarns in a woven fabric or in a woven hose jacket, (2) the deviation from a straight line of a hose while subjected to internal pressure.

water resistant: having the ability to withstand the deteriorating effect of water.

wavy tube: a tube or lining with an inner surface having surface ripples formed by the pattern of the reinforcement.

weathering: the surface deterioration of a hose cover during outdoor exposure, as shown by checking, cracking, crazing and chalking.

weft: a term used for filling. See filling. weftless cord fabric: a cord fabric either without filling yarns or with a few small filling yarns widely spaced.

wire braid: see braid.

wire loop: in braided hose, a loop in the wire reinforcement caused by uneven tensions during bobbin winding or braiding.

wire reinforced: a hose containing wires to give added strength, increased dimensional stability, or crush resistance. See also: reinforcement.

wire throw-out: (1) in braided hose, a broken end or ends in the wire reinforcement protruding from the surface of the braid; (2) a displaced coil in rough bore hose.

wire wound: having a single wire or a plurality of wires spiraled in one or more layers as a protective or reinforcing member.

wire woven: woven with the wire reinforcement applied helically by means of a circular loom.

working pressure: the maximum pressure to which a hose will be subjected, including the momentary surges in pressure which can occur during service Abbreviated as WP.

woven fabric: a flat structure composed of two series of interlacing yarns or filaments, one parallel to the axis of the fabric and the other transverse.

woven jacket: see jacket.

WP: the abbreviation for working pressure.

wrap: see straight wrap and cross wrap.

wrapped cure: a vulcanizing process using a tensioned wrapper (usually of fabric) to apply external pressure.

wrapper marks: the impressions left on the surface of a hose by a material used during vulcanization. Usually shows characteristics of a woven pattern and wrapper edge marks; see also: wrapped cure; wrinkled ply; buckled ply.

yarn: a generic term for continuous strands of textile fibers or filaments in a form suitable for knitting, weaving, or otherwise intertwining to form a textile fabric. It may comprise: (a) a number of fibers twisted together, (b) a number of filaments laid together without twist (a zero-twist yarn), (c) a number of filaments laid together with more or less twist, (d) a single filament with or without twist (a mono-filament), or (e) one or more strips made by the lengthwise division of a sheet of material, such as a natural or synthetic polymer, a paper or metal foil used with or without twist in a textile construction.

yarn number: the number of hanks in a pound, usually cotton.

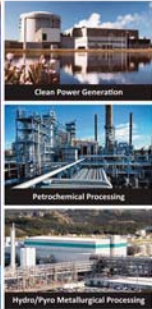

METALLIC HOSE ASSEMBLIES Engineered Solutions For Pipe Motion



Metallic Hose Assemblies Catalog

Thorburn Flex provides end-user engineered solutions for pipe motion. You specify the operating conditions and we will produce a custom metal hose assembly that will satisfy the operating conditions. Thorburn's metal hose assemblies may be exceptionally flexible, or you may need several hoses encapsulated in outer hose: a jacketed hose for heat exchange; an armoured hose; a hose to carry sensitive cables; an articulated robotic cover; an insulated hose; a colour coded hose. Our "Can-Do" design specialists are only a phone call away.

Applications



Clean Power Generation



LNG Transfer



Petro-Chemical Processing



Pulp & Paper Processing



PTFE HOSE ASSEMBLIES Engineered Solutions For Pipe Motion



PTFE Hose Assemblies Catalog

Thorburn Flex offers a complete range of custom engineered solutions for pipe motion in applications including chemical, steam, pharmaceutical, food and beverage. Thorburn PTFE hose assemblies offer the end user chemical inertness, low friction, non-contaminating and non-conductivity. All these features of Thorburn's PTFE hose assemblies can be leveraged into hundreds of demanding applications.

Applications



Pharmaceutical, Food and Beverage



Automotive and Aerospace



Petro-Chemical Processing



High Temperature Autoclaves

THORBURN FLEX - Canada
 165 Oneida, Pointe-Claire, Quebec
 Canada, H9R 1A9
 Tel: +1-514-695-8710
 Fax: +1-514-695-1321
 sales@thorburnflex.com



ISCIR Romania | CNCAN Romania | EN 13480-2002 | HAF 604 China | TSG China
 (CRN for all Canadian Provinces)

Thorburn's Global Presence

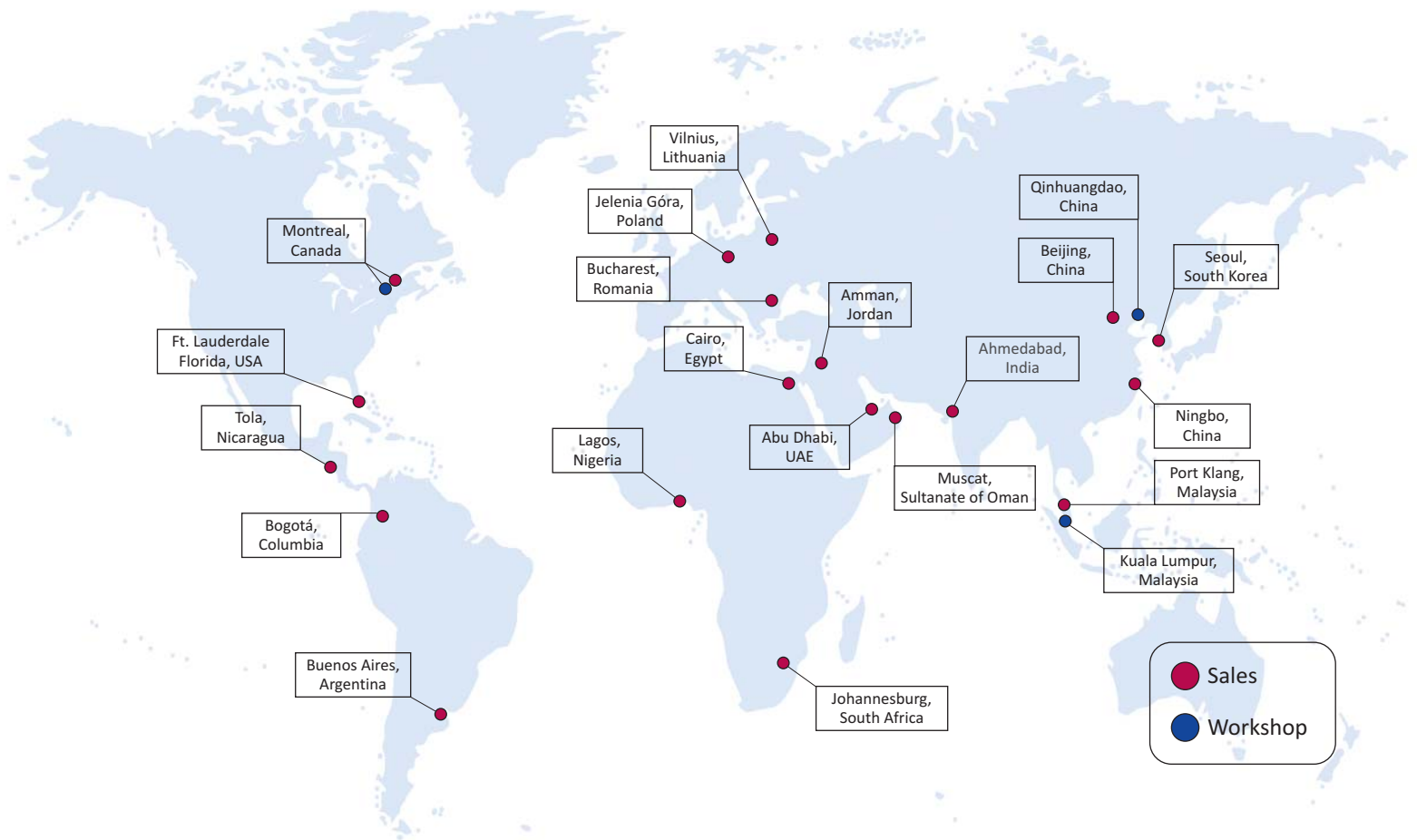

www.thorburnflex.com